

# L-force *Drives*

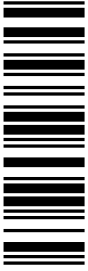

Translation **Hardware Manual**

## 8400 motec 0.37 ... 7.5 kW

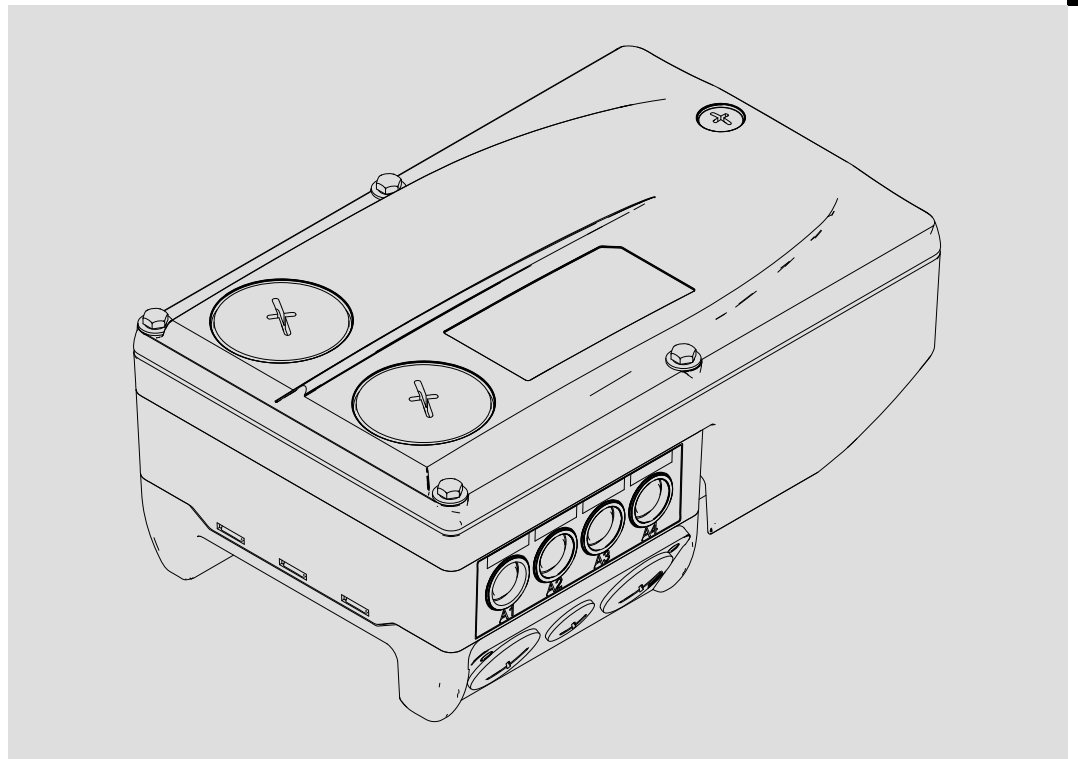

**E84DVBM...**  
**Zx5...**

**Decentralised frequency inverter**



<b>1</b>	<b>About this documentation</b> .....	<b>8</b>
1.1	Validity information .....	8
1.2	Document history .....	9
1.3	Conventions used .....	10
1.4	Terms and abbreviations used .....	11
1.5	Notes used .....	12
<b>2</b>	<b>Safety instructions</b> .....	<b>13</b>
2.1	General safety and application notes for Lenze controllers .....	13
2.2	General safety and application notes for Lenze motors .....	16
2.3	Residual hazards .....	19
<b>3</b>	<b>Product description</b> .....	<b>20</b>
3.1	System overview .....	20
3.2	Device features .....	21
3.3	Identification .....	23
3.4	Product key .....	24
3.4.1	Wiring Unit .....	24
3.4.2	Frame Unit .....	25
3.4.3	Communication Unit .....	26
3.4.4	Drive Unit .....	26
3.4.5	Motor mounting set .....	27
3.4.6	Wall mounting without switch .....	28
3.4.7	Wall mounting with switch .....	29
3.5	Overview of control terminals .....	30
<b>4</b>	<b>Technical data</b> .....	<b>32</b>
4.1	General data and operating conditions .....	32
4.2	Rated data .....	37
4.2.1	Overview .....	37
4.2.2	Operation at rated mains voltage 400 V .....	39
4.2.3	Operation with increased power at a 400 V mains .....	41
4.2.4	Operation with rated mains voltage 480 V .....	43
4.2.5	Operation with increased power on a 480 V system .....	45
4.3	Device protection by current derating .....	47
4.3.1	Wall mounting without switch .....	47
4.3.2	Wall mounting with switch .....	50
4.4	Overcurrent operation .....	53
4.5	Switching frequency reduction .....	55

4.6	Power terminals .....	56
4.6.1	8400 motec 0.37 ... 3 kW .....	56
4.6.2	8400 motec 4 ... 7.5 kW .....	59
4.6.3	8400 motec wall mounting .....	62
4.7	Control terminals .....	65
4.7.1	Overview .....	65
4.7.2	General data .....	66
4.7.3	AS-Interface .....	68
4.7.4	CANopen® .....	68
4.7.5	EtherCAT® .....	69
4.7.6	EtherNet/IP™ .....	69
4.7.7	PROFIBUS® .....	70
4.7.8	PROFINET® .....	70
4.7.9	POWERLINK .....	71
4.8	Dimensions .....	72
4.8.1	Standard motor mounting .....	72
4.8.2	Wall mounting without switch .....	73
4.8.3	Wall mounting with switch .....	74
<b>5</b>	<b>Installation .....</b>	<b>75</b>
5.1	Important notes .....	75
5.2	Safety instructions for the installation according to UL/CSA .....	78
5.3	Installation according to EMC (installation of a CE-typical drive system) .....	80
5.3.1	Shielding .....	80
5.3.2	Motor cable .....	81
5.3.3	Control cables .....	82
5.3.4	Detecting and eliminating EMC interferences .....	82
5.4	Installation of 8400 motec pre-assembled on the motor .....	83
5.4.1	Installation instructions .....	83
5.4.2	Plug at the Wiring Unit .....	83
5.4.3	Attaching the cable gland .....	84
5.5	Retrofitting the 8400 motec controller .....	86
5.5.1	Installation instructions .....	86
5.5.2	Preparing a motor for the 8400 motec installation .....	86
5.5.3	Mounting the Wiring Unit .....	87
5.5.4	Mounting of the Communication Unit .....	88
5.5.5	Settings at the Drive Unit .....	89
5.5.6	Mounting of the Drive Unit .....	89
5.6	Measures when drive is used in IT systems .....	91

5.7	Wall mounting .....	92
5.7.1	Installation instructions .....	92
5.7.2	Wall adapter for 4 ... 7.5 kW .....	93
5.7.3	Wall mounting without switch .....	94
5.7.4	Wall mounting with switch .....	94
5.8	Power terminals .....	95
5.8.1	Standard motor mounting .....	95
5.8.2	Product extensions .....	96
5.8.3	Wall mounting without switch .....	97
5.8.4	Product extensions .....	104
5.8.5	Wall mounting with switch .....	106
5.8.6	E84DGS3 KC xxND .....	109
5.8.7	E84DGS3 KCBxND .....	110
5.8.8	E84DGS3 KCExND .....	111
5.8.9	E84DGS3 KCKxND .....	112
5.9	Control terminals .....	114
5.9.1	Basic I/O .....	114
5.9.2	Standard I/O .....	115
5.9.3	Standard I/O + M12 .....	116
5.9.4	Extended I/O .....	117
5.9.5	AS-Interface .....	118
5.9.6	AS-Interface STO .....	120
5.9.7	CANopen® .....	122
5.9.8	CANopen® STO .....	124
5.9.9	EtherCAT® .....	126
5.9.10	EtherCAT® STO .....	128
5.9.11	EtherNet/IP™ .....	130
5.9.12	EtherNet/IP™ STO .....	132
5.9.13	PROFIBUS® .....	134
5.9.14	PROFIBUS® STO .....	136
5.9.15	PROFINET® .....	138
5.9.16	PROFINET® STO .....	140
5.9.17	POWERLINK .....	142
5.9.18	POWERLINK STO .....	144
<b>6</b>	<b>Commissioning .....</b>	<b>146</b>
6.1	Before you start .....	146
6.2	Handling the memory module .....	148
6.3	Commissioning via DIP switch/potentiometer .....	150
6.3.1	DIP switch / potentiometer assignment 0 .....	153
6.3.2	DIP switch / potentiometer assignment 1 .....	156
6.3.3	Before switching on .....	160
6.3.4	Commissioning steps .....	161

6.4	Commissioning via the diagnosis terminal .....	162
6.4.1	Display elements and function keys .....	163
6.4.2	Menu structure .....	164
6.4.3	User menu .....	165
6.4.4	Commissioning steps .....	166
6.4.5	SET mode .....	169
6.5	Diagnostics .....	170
<b>7</b>	<b>Braking operation .....</b>	<b>171</b>
7.1	Braking operation without additional measures .....	171
7.2	Braking operation with brake resistor .....	172
7.2.1	Selection of the brake resistors .....	172
7.2.2	Wiring of brake resistor .....	173
7.3	Operation with spring-applied brake .....	176
7.3.1	Introduction .....	176
7.3.2	Wiring .....	176
<b>8</b>	<b>Safety engineering .....</b>	<b>177</b>
8.1	Introduction .....	177
8.2	Important notes .....	178
8.2.1	Hazard and risk analysis .....	179
8.2.2	Standards .....	179
8.3	Basics for safety sensors .....	180
8.4	Operating mode .....	181
8.4.1	Introduction .....	181
8.4.2	Disconnecting paths .....	181
8.4.3	Safety status .....	182
8.5	Technical data .....	183
8.6	Electrical installation .....	185
8.7	Certification .....	186
<b>9</b>	<b>Accessories (overview) .....</b>	<b>187</b>
9.1	Wall mounting .....	187
9.1.1	Wall adapter for 4 ... 7.5 kW .....	187
9.1.2	Frame Unit without switch .....	188
9.1.3	Frame Unit with switch .....	189
9.2	Plug connectors .....	191
9.2.1	M12 plug-in connector .....	191
9.2.2	Plug-in modules .....	191
9.2.3	QUICKON connector .....	192
9.2.4	M15 plug .....	192
9.3	Memory module .....	193

9.4	Diagnosis terminal .....	194
9.5	Switch/potentiometer unit .....	195
9.6	External brake resistors - mounting variant .....	196
9.7	External brake resistors .....	197
<b>10</b>	<b>Appendix .....</b>	<b>198</b>
10.1	Total index .....	198

# 1 About this documentation

Validity information

## 1 About this documentation

### 1.1 Validity information

#### Contents

This Hardware Manual informs you how to use the motec version of the 8400 controller series as directed.

#### Validity

Type	Type designation	from hardware version	from software version
8400 motec	E84DVB...	VA	01.00

#### Target group

This Hardware Manual is intended for all persons who design, install, commission, and adjust controllers of the 8400 Inverter Drives product range.



#### Tip!

Information and tools concerning the Lenze products can be found in the download area at [www.lenze.com](http://www.lenze.com)

## 1.2 Document history

Material number	Version			Description
13563424	8.1	02/2019	TD15	General revision, supplements, and corrections
13563424	8.0	12/2018	TD15	General revision, supplements, and corrections
13549848	7.0	02/2018	TD18	General revision, supplements, and corrections
13516173	6.0	07/2016	TD29	General revision, supplements, and corrections
13424192	5.0	12/2014	TD15	UL notes in French for Canada EAC conformity General corrections
13410317	4.0	06/2012	TD15	General revision, supplements, and corrections
13392581	3.0	11/2011	TD15	Extension 4 ... 7.5 kW
13373547	2.0	04/2011	TD15	Extension 2.2 ... 3 kW, PROFINET, EtherCAT
13368432	1.1	01/2011	TD15	General revision, supplements, and corrections
13336684	1.0	09/2010	TD15	First edition

# 1 About this documentation

## Conventions used

### 1.3 Conventions used

This documentation uses the following conventions to distinguish between different types of information:

#### Spelling of numbers

Decimal separator	Point	In general, the decimal point is used. For instance: 1234.56
-------------------	-------	---





#### Warnings

UL warnings		Given in English and French
UR warnings		

#### Text

Program name	» «	PC software For example: »Engineer«, »Global Drive Control« (GDC)
--------------	-----	--

#### Icons

Page reference		Reference to another page with additional information For instance:  16 = see page 16
Documentation reference		Reference to another documentation with additional information For example:  EDKxxx = see documentation EDKxxx

## 1.4 Terms and abbreviations used

<b>Term</b>	<b>Meaning</b>
Device size	Used as generic term for a group of devices which have the same dimensions (depth, height and width) but different power ratings.
Standard device	Used as generic term when actions and features are described which are very similar or the same for different versions or device sizes, e.g. <ul style="list-style-type: none"> <li>● mechanical installation or</li> <li>● power terminals</li> </ul>
DU	Drive unit 8400 motec controller
CU	Communication unit Optional interfaces per I/O, fieldbus, safety system
WU	Wiring unit Ready-made motor connection, replaces the motor terminal box

<b>Abbreviation</b>	<b>Meaning</b>
240	24 V voltage supply for non-safe monitoring
Cat.	Category according to EN 954-1 (valid until 30 November 2009)
DO	Non-safe feedback output
F-PLC	Safety PLC
GSDML	File containing device-specific data to establish PROFINET communication
GSE	File containing device-specific data to establish PROFIBUS communication
OFF state	Signal status of the safety sensors when they are activated or respond
ON state	Signal status of the safety sensors during normal operation
Opto supply	Optocoupler supply for controlling the drivers
OSSD	Output Signal Switching Device, tested signal output
PELV	Protective Extra Low Voltage
PL	Performance Level according to EN ISO 13849-1
PM	P/N switching signal paths
PP	P/P switching signal paths
PS	PROFIsafe
PWM	Pulse Width Modulation
S-Bus	Safety bus
SD-In	Safe input (Safe Digital Input)
SD-Out	Safe output (Safe Digital Output)
SELV	Safety Extra Low Voltage
SIA, SIB	Safe Input, channel A or B, respectively
SIL	Safety Integrity Level according to IEC 61508
SO	Integrated safety option

n. c. Terminal not assigned

<b>Abbreviation</b>	<b>Safety function</b>
STO	Safe Torque Off Former designation: safe standstill

# 1 About this documentation

## Notes used

### 1.5 Notes used

The following pictographs and signal words are used in this documentation to indicate dangers and important information:

#### Safety instructions

Structure of safety instructions:





#### **Danger!**



(characterises the type and severity of danger)

#### **Note**



(describes the danger and gives information about how to prevent dangerous situations)

Pictograph and signal word	Meaning
 <b>Danger!</b>	<b>Danger of personal injury through dangerous electrical voltage.</b> Reference to an imminent danger that may result in death or serious personal injury if the corresponding measures are not taken.
 <b>Danger!</b>	<b>Danger of personal injury through a general source of danger.</b> Reference to an imminent danger that may result in death or serious personal injury if the corresponding measures are not taken.
 <b>Stop!</b>	<b>Danger of property damage.</b> Reference to a possible danger that may result in property damage if the corresponding measures are not taken.

#### Application notes

Pictograph and signal word	Meaning
 <b>Note!</b>	Important note to ensure troublefree operation
 <b>Tip!</b>	Useful tip for simple handling
	Reference to another documentation

#### Special safety instructions and application notes

Pictograph and signal word	Meaning
 <b>Warnings!</b>	<b>Safety note or application note for the operation according to UL or CSA requirements.</b>
 <b>Warnings!</b>	The measures are required to meet the requirements according to UL or CSA.

## 2 Safety instructions

### 2.1 General safety and application notes for Lenze controllers

(in accordance with Low-Voltage Directive 2014/35/EU)

#### For your personal safety

Disregarding the following basic safety measures may lead to severe personal injury and damage to material assets:

- ▶ Use the product as intended.
- ▶ Never operate the product if damages are visible.
- ▶ Never operate the product unless fully assembled.
- ▶ Do not make any technical changes to the product.
- ▶ Only use the accessories approved for the product.
- ▶ Only use original spare parts of the manufacturer.
- ▶ Observe all regulations for the prevention of accidents, directives and laws applicable on site.
- ▶ Transport, installation, commissioning and maintenance work must only be carried out by qualified personnel.
  - Observe IEC 364 and CENELEC HD 384 or DIN VDE 0100 and IEC report 664 or DIN VDE 0110 and all national regulations for the prevention of accidents.
  - According to the basic safety information, qualified, skilled personnel are persons who are familiar with the assembly, installation, commissioning, and operation of the product and who have the qualifications necessary for their occupation.
- ▶ Observe all specifications in this documentation.
  - This is the condition for safe and troublefree operation and the achievement of the specified product features.
  - The procedural notes and circuit details described in this documentation are only proposals. It is up to the user to check whether they can be transferred to the particular applications. Lenze Drives GmbH does not accept any liability for the suitability of the procedures and circuit proposals described.
- ▶ Lenze inverters (frequency inverters, servo inverters, DC speed controllers) and the accessory components can include live and moving parts (depending on their type of protection) during operation. Surfaces can be hot.
  - Nonauthorized removal of the required cover, inappropriate use, incorrect installation or operation create the risk of severe injury to persons or damage to material assets.
  - For more information, please see the documentation.
- ▶ High amounts of energy are produced in the drive. Therefore it is required to wear personal protective equipment (body protection, headgear, eye and ear protection, hand guard).

**Application as directed**

Inverters are components which are designed for installation in electrical systems or machines. They are not to be used as domestic appliances, but only for industrial purposes according to EN 6100032.

When inverters are installed into machines, commissioning (i.e. starting of the operation as directed) is prohibited until it is proven that the machine complies with the regulations of the EC Directive 2006/42/EC (Machinery Directive); EN 60204 must be observed.

Commissioning (i.e. starting of the operation as directed) is only allowed when there is compliance with the EMC Directive (2014/30/EU).

The inverters meet the requirements of the Low-Voltage Directive 2006/35/EU. The harmonised standard EN 61800-5-1 applies to the inverters.

The technical data and supply conditions can be obtained from the nameplate and the documentation. They must be strictly observed.

**Warning:** Inverters are products which can be installed in drive systems of category C2 according to EN 61800-3. These products can cause radio interferences in residential areas. In this case, special measures can be necessary.

**Transport, storage**

Observe the notes on transport, storage, and appropriate handling.

Observe the climatic conditions according to the technical data.

**Installation**

The inverters must be installed and cooled according to the instructions given in the corresponding documentation.

The ambient air must not exceed degree of pollution 2 according to EN 61800-5-1.

Ensure proper handling and avoid excessive mechanical stress. Do not bend any components and do not change any insulation distances during transport or handling. Do not touch any electronic components and contacts.

Inverters contain electrostatic sensitive devices which can easily be damaged by inappropriate handling. Do not damage or destroy any electrical components since this might endanger your health!

**Electrical connection**

When working on live inverters, observe the applicable national regulations for the prevention of accidents.

The electrical installation must be carried out according to the appropriate regulations (e.g. cable cross-sections, fuses, PE connection). Additional information can be obtained from the documentation.

This documentation contains information on installation in compliance with EMC (shielding, earthing, filter, and cables). These notes must also be observed for CE-marked inverters. The manufacturer of the system is responsible for compliance with the limit values demanded by EMC legislation.

Lenze inverters may cause a DC current in the PE conductor. If a residual current device (RCD) is used for protection against direct or indirect contact for an inverter with three-phase supply, only a residual current device (RCD) of type B is permissible on the supply side of the inverter. If the inverter has a single-phase supply, a residual current device (RCD) of type A is also permissible. Apart from using a residual current device (RCD), other protective measures can be taken as well, e.g. electrical isolation by double or reinforced insulation or isolation from the supply system by means of a transformer.

### Operation

If necessary, systems including inverters must be equipped with additional monitoring and protection devices according to the valid safety regulations (e.g. law on technical equipment, regulations for the prevention of accidents). The inverters can be adapted to your application. Please observe the corresponding information given in the documentation.

After the inverter has been disconnected from the supply voltage, all live components and power terminals must not be touched immediately because capacitors can still be charged. Please observe the corresponding stickers on the inverter.

All protection covers and doors must be shut during operation.

**Note for UL-approved systems with installed inverters:** UL warnings are notes that only apply to UL systems. The documentation contains special UL notes.

### Safety functions

Certain inverter versions support safety functions (e.g. "Safe torque off", formerly "Safe standstill") according to the requirements of the EC Directive 2006/42/EC (Machinery Directive). The notes on the integrated safety system provided in this documentation must be observed.

### Maintenance and servicing

The inverters do not require any maintenance if the prescribed operating conditions are observed.

### Disposal

Recycle metal and plastic materials. Ensure professional disposal of assembled PCBs.

**The product-specific safety and application notes given in these instructions must be observed!**

**2.2 General safety and application notes for Lenze motors**

(according to Low-Voltage Directive 2014/35/EU)

**General**

Low-voltage machines have dangerous, live and rotating parts as well as possibly hot surfaces.

Synchronous machines induce voltages at open terminals during operation.

All operations serving transport, connection, commissioning and maintenance are to be carried out by skilled, responsible technical personnel (observe EN 50110-1 (VDE 0105-1) and IEC 60364). Improper handling can cause severe injuries or damages.

Lowvoltage machines may only be operated under the conditions that are indicated in the section "Application as directed".

The conditions at the place of installation must comply with the data given on the nameplate and in the documentation.

**Application as directed**

Lowvoltage machines are intended for commercial installations. They comply with the harmonised standards of the series IEC/EN 60034 (VDE 0530). Their use in potentially explosive atmospheres is prohibited unless they are expressly intended for such use (follow additional instructions).

Lowvoltage machines are components for installation into machines as defined in the Machinery Directive 2006/42/EC. Commissioning is prohibited until the conformity of the end product with this directive has been established (follow i. a. EN 60204-1).

Lowvoltage machines with IP23 protection or less are only intended for outdoor use when applying special protective features.

The integrated brakes must not be used as safety brakes. It cannot be ruled out that factors which cannot be influenced, such as oil ingress due to a defective Aside shaft seal, cause a brake torque reduction.

**Transport, storage**

Damages must be reported immediately upon receipt to the forwarder; if required, commissioning must be excluded. Tighten screwed in ring bolts before transport. They are designed for the weight of the lowvoltage machines, do not apply extra loads. If necessary, use suitable and adequately dimensioned means of transport (e. g. rope guides).

Remove transport locking devices before commissioning. Reuse them for further transport. When storing low-voltage machines, ensure a dry, dustfree and low-vibration ( $v_{\text{eff}} \leq 0.2 \text{ mm/s}$ ) environment (bearing damage while being stored).

### Installation

Ensure an even surface, solid foot/flange mounting and exact alignment if a direct clutch is connected. Avoid resonances with the rotational frequency and double mains frequency which may be caused by the assembly. Turn rotor by hand, listen for unusual slipping noises. Check the direction of rotation when the clutch is not active (observe section "Electrical connection").

Use appropriate means to mount or remove belt pulleys and clutches (heating) and cover them with a touch guard. Avoid impermissible belt tensions.

The machines are halfkey balanced. The clutch must be halfkey balanced, too. The visible jutting out part of the key must be removed.

If required, provide pipe connections. Designs with shaft end at bottom must be protected with a cover which prevents the ingress of foreign particles into the fan. Free circulation of the cooling air must be ensured. The exhaust air also the exhaust air of other machines next to the drive system must not be taken in immediately.

### Electrical connection

All operations must only be carried out by qualified and skilled personnel on the lowvoltage machine at standstill and deenergised and provided with a safe guard to prevent an unintentional restart. This also applies to auxiliary circuits (e. g. brake, encoder, blower).

Check safe isolation from supply!

If the tolerances specified in EN 600341; IEC 34 (VDE 05301) voltage  $\pm 5\%$ , frequency  $\pm 2\%$ , waveform, symmetry are exceeded, more heat will be generated and the electromagnetic compatibility will be affected.

Observe the data on the nameplate, operating notes, and the connection diagram in the terminal box.

The connection must ensure a continuous and safe electrical supply (no loose wire ends); use appropriate cable terminals. The connection to the PE conductor must be safe. The plug-in connectors must be bolted tightly (tostop).

The clearances between blank, live parts and to earth must not fall below 8 mm at  $V_{\text{rated}} \leq 550\text{ V}$ , 10 mm at  $V_{\text{rated}} \leq 725\text{ V}$ , 14 mm at  $V_{\text{rated}} \leq 1000\text{ V}$ .

The terminal box must be free of foreign particles, dirt and moisture. All unused cable entries and the box itself must be sealed against dust and water.

**Commissioning and operation**

Before commissioning after longer storage periods, measure insulation resistance. In case of values  $\leq 1 \text{ k}\Omega$  per volt of rated voltage, dry winding.

For trial run without output elements, lock the featherkey. Do not deactivate the protective devices, not even in a trial run.

Check the correct operation of the brake before commissioning lowvoltage machines with brakes.

Integrated thermal detectors do not provide full protection for the machine. If necessary, limit the maximum current. Parameterise the controller so that the motor will be switched off with  $I > I_{\text{rated}}$  after a few seconds of operation, especially at the risk of blocking.

Vibrational severities  $v_{\text{eff}} \leq 3.5 \text{ mm/s}$  ( $P_{\text{rated}} \leq 15 \text{ kW}$ ) or  $4.5 \text{ mm/s}$  ( $P_{\text{rated}} > 15 \text{ kW}$ ) are acceptable if the clutch is activated.

If deviations from normal operation occur, e.g. increased temperatures, noises, vibrations, find the cause and, if required, contact the manufacturer. In case of doubt, switch off the lowvoltage machine.

If the machine is exposed to dirt, clean the air paths regularly.

Shaft sealing rings and roller bearings have a limited service life.

Regrease bearings with relubricating devices while the lowvoltage machine is running. Only use the grease recommended by the manufacturer. If the grease drain holes are sealed with a plug, (IP54 drive end; IP23 drive and nondrive end), remove plug before commissioning. Seal bore holes with grease. Replace prelubricated bearings (2Z bearing) after approx. 10,000 h 20,000 h, at the latest however after 3 4 years.

**The product-specific safety and application notes given in these instructions must be observed!!**

## 2.3 Residual hazards

### Protection of persons

- ▶ Switch off mains voltage before removing the controller (Drive Unit).
- ▶ Before working on the controller, check if no voltage is applied to the power terminals because
  - depending on the device - the power terminals U, V, W, Rb1, Rb2, T1 and T2 remain live for at least 3 minutes after disconnecting the mains.
  - the power terminals L1, L2, L3; U, V, W, Rb1, Rb2, T1 and T2 remain live when the motor is stopped.

### Device protection

- ▶ Only connect/disconnect all pluggable terminals in deenergised condition!
- ▶ Only disconnect the inverters from the installation, e.g. from the motor or mounting wall, in deenergised condition!
- ▶ Close all unused connectors with protection covers or blanking plugs.





### Motor protection

- ▶ With some settings of the controller, the connected motor can be overheated.
  - E.g. longer operation of the DC injection brake.
  - Longer operation of self-ventilated motors at low speed.
  - Wrong frequency or voltage settings in the motor parameters (especially with 120 Hz motors).

### Protection of the machine/system

- ▶ Drives can reach dangerous overspeeds (e.g. setting of high output frequencies in connection with motors and machines unsuitable for such conditions):
  - The controllers do not offer any protection against such operating conditions. Use additional components for this purpose.

### Warning by symbols

Icon	Description
	<b>Long discharge time:</b> All power terminals remain live for up to 3 minutes after mains disconnection!
	<b>High leakage current:</b> Carry out fixed installation and PE connection in accordance with EN 61800-5-1!
	<b>Electrostatic sensitive devices:</b> Before working on the device, the staff must ensure to be free of electrostatic charge!
	<b>Hot surface:</b> Use personal protective equipment or wait until devices have cooled down!

### 3 Product description

#### System overview

### 3 Product description

#### 3.1 System overview

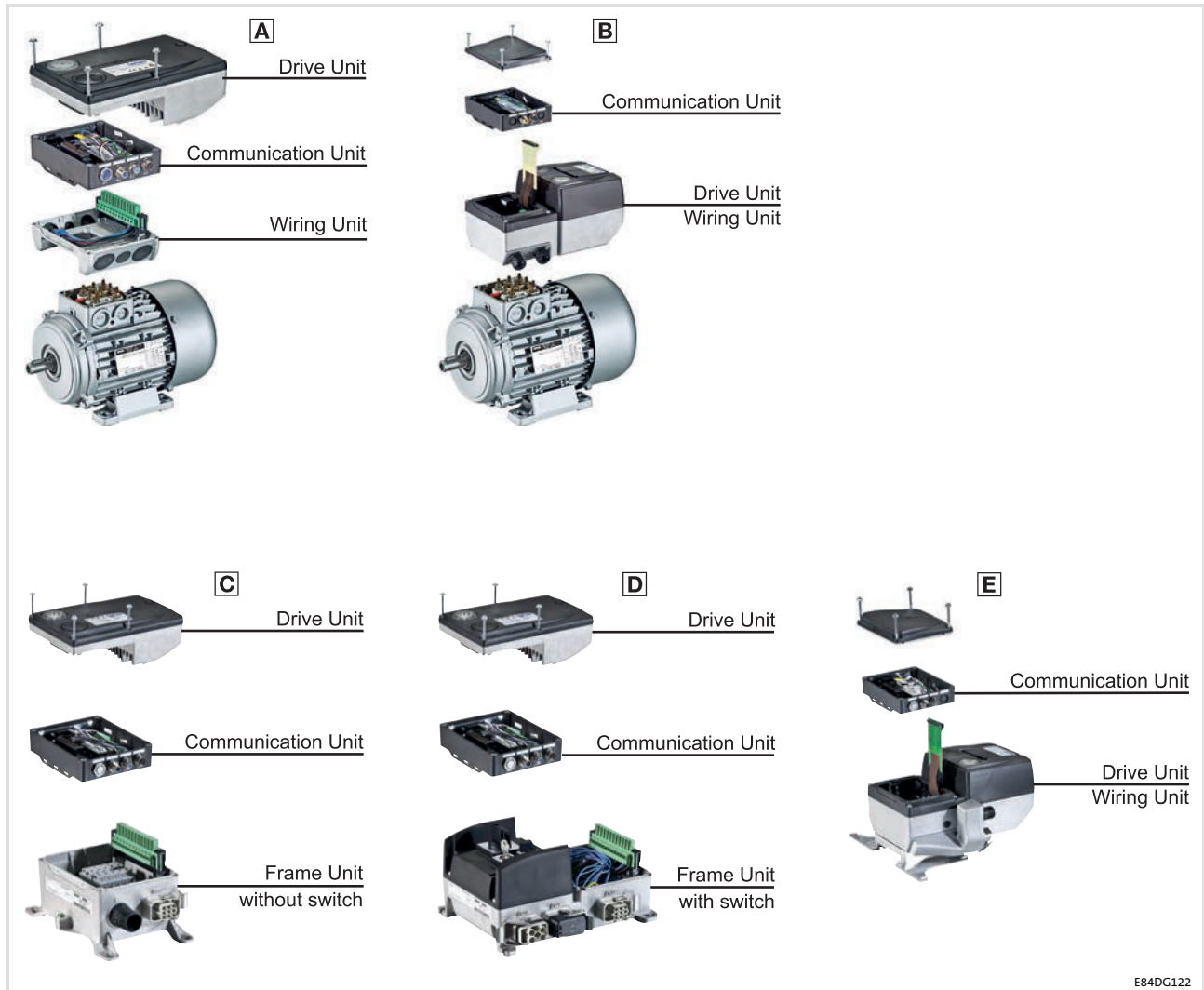

- A** 8400 motec 0.37 ... 3.0 kW
- B** 8400 motec 4.0 ... 7.5 kW
- C** 8400 motec wall mounting without switch 0.37 ... 3.0 kW
- D** 8400 motec wall mounting with switch 0.37 ... 3.0 kW
- E** 8400 motec wall mounting without switch 4.0 ... 7.5 kW

## **3.2 Device features**

### **General features**

- ▶ Compact motor inverter
- ▶ Modular design
- ▶ Part of the Inverter Drives 8400 product family
  - Identical product features
  - Identical operation
- ▶ Scalable fieldbus communication (optional)
- ▶ On site diagnostics per status LEDs
- ▶ Extensive accessories (optional)
- ▶ Pluggable memory module
- ▶ Quick commissioning via DIP switches

## Functional features

Features	Type	
Power range	0.37 ... 7.5 kW	
Fieldbus communication (optional)	<ul style="list-style-type: none"> <li>– AS interface</li> <li>– CANopen</li> <li>– EtherNet/IP</li> <li>– POWERLINK</li> <li>– PROFIBUS</li> <li>– PROFINET</li> <li>– EtherCAT</li> </ul>	
Integrated interference suppression in accordance with EN 61800-3	✓	
Flying restart circuit	✓	
Integrated brake management	✓	
Integrated brake chopper	✓	
Integrated brake resistor	Optional	
Integrated safety system	Optional: "Safe torque off (STO)"	
Modes of operation	<ul style="list-style-type: none"> <li>– Sensorless vector control - torque/speed (SLVC)</li> <li>– Sensorless control (SL-PSM)</li> <li>– U/f open loop, linear and square-law (VFCplus)</li> <li>– Energy saving function (VFC eco)</li> <li>– V/f characteristic control (VFC closed loop)</li> </ul>	
S-shaped ramps for almost jerk-free acceleration and deceleration	✓	
Fixed frequencies	3	
Overload current	200 % (3 s)	
IT system usability	✓	
Incremental encoder evaluation	two-track, 7.5 kHz	<ul style="list-style-type: none"> <li>– CANopen</li> <li>– PROFIBUS</li> <li>– AS interface</li> </ul>
	Two-track, 10 kHz	<ul style="list-style-type: none"> <li>– EtherNet/IP</li> <li>– POWERLINK</li> <li>– PROFINET</li> <li>– EtherCAT</li> </ul>
outputs	Optional: 1 digital output 1 potential-free relay contact, 2 A, NO contact	
DC-injection braking	✓	
Mounting	Motor mounting Optional: vertical wall mounting, cooling ribs on the top	

### 3.3 Identification

Due to the modular design of the 8400 motec controllers, every unit has an own nameplate.

The nameplate shows the type designation of the respective unit. The type designation serves to exactly identify a unit.



① Type designation

#### Note

Via the type designation, detailed device properties can be identified using the following type code. The list containing the type code, features, and device properties does not take any restrictions with regard to possible combinations into consideration.

### 3 Product description

Product key  
Wiring Unit

#### 3.4 Product key

Due to the modular structure of the 8400 motec inverter, every unit needs an own type key. Although a type key is also defined for the 8400 motec inverter as a set, for practical and logistical reasons it cannot be fixed visibly on the set or on the individual units.

The following lists inform you about the type keys for:

- ▶ **Wiring Unit**  
Wiring level to the motor and mains connection
- ▶ **Communication Unit**  
Connection level for fieldbus communication and further inputs and outputs, partially optional
- ▶ **Drive Unit**  
8400 motec inverter
- ▶ **Accessories**  
Efficiency-enhancing and cost-cutting

##### 3.4.1 Wiring Unit

	E84DGV	N	x	E
<b>Module part</b> Wiring Unit - 8400 motec				
<b>Version</b> N = not relevant				
<b>Size</b> 1 = 063 / 071 (E84DGDVB3714 ... 1124) 2 = 080 / 090 / 100 (E84DGDVB5514 ... 1524) 3 = 080 / 090 / 100 / 112 (E84DGDVB2224 ... 3024) 4 = 080 / 090 / 100 / 112 (E84DGDVB4024 ... 7524) 5 = 132 (E84DGDVB5524 ... 7524)				
<b>Enclosure</b> E = IP66				

3.4.2 Frame Unit

	①							
	E84DGS	x	x	x	x	x	N	x
<b>Module part</b> Frame Unit 8400 motec								
<b>Design</b> 2 = without switch 3 = with switch								
<b>Type of mains connection</b> E = cable gland I = M15 K = 2 × Q4/2, loop through L = cable gland, loop through S = Quickon								
<b>Type of motor connection</b> C = Q8/0 E = cable gland								
<b>Control element</b> N = without B = service switch E = service switch with control elements K = service switch with protective function								
<b>Brake resistor</b> L = externally via Q5/0, on the left (position 5) M = externally via Q5/0, on the right (position 3) N = without C = 220 Ohm K = 90 Ohm								
<b>Fan</b> N = without								
<b>Degree of protection</b> D = IP54 P = IP65								

### 3 Product description

Product key  
Communication Unit

#### 3.4.3 Communication Unit

	E84DGFC	x	x	x	P
<b>Module part</b> Communication Unit - 8400 motec					
<b>I/O modules/fieldbus</b> N = basic I/O (without fieldbus link) S = standard I/O (without fieldbus link) X = extended I/O (without fieldbus link) A = AS-Interface C = CANopen G = EtherNet/IP L = POWERLINK P = PROFIBUS R = PROFINET T = EtherCAT®					
<b>Connection technique for I/O modules/fieldbus</b> N = basic I/O, standard I/O, extended I/O: terminal 1 = Standard I/O + M12: 3 x DI, 1 x DO E = M12: bus, 3 x DI, 1 x DO (integrated safety: N) E = STO, M12: bus, 2 x DI, 1 x DO, AI, NO, STO (integrated safety: J) F = M12: bus, 2 x DI					
<b>Integrated safety system</b> N = none J = STO (safe torque off)					
<b>Degree of protection</b> P = IP65					

#### 3.4.4 Drive Unit

	E84DGDV	B	xxx	4	2	P	x
<b>Module part</b> Drive Unit - 8400 motec							
<b>Version</b> B = not relevant							
<b>Power e.g.</b> 152 = $15 \times 10^2 \text{ W} = 1.5 \text{ kW}$							
<b>Voltage class</b> 4 = 400/480 V, 3/PE AC (also for IT systems)							
<b>Memory module</b> 2 = standard 8400 motec							
<b>Type of protection</b> P = IP65							
<b>Control element</b> S = standard (DIP switches/potentiometer/X70) P = version P1 (only potentiometer P1)							

3.4.5 Motor mounting set

	①											
	E84DV	B	x	xxx	4	S	x	x	x	2	P	x
<b>Product range</b> Inverter Drives 8400 motec												
<b>Type</b> B = not relevant												
<b>Design</b> M = motor-mounted device W = wall-mounted device												
<b>Power e.g.</b> 152 = 15 x 10 <sup>2</sup> W = 1.5 kW												
<b>Voltage class</b> 4 = 400/480 V, 3/PE AC (also for IT systems)												
<b>Control element</b> S = standard (DIP switches/potentiometer/X70)												
<b>I/O modules / fieldbus</b> N = basic I/O (without fieldbus) S = standard I/O (without fieldbus) X = extended I/O (without fieldbus) A = AS-Interface C = CANopen G = EtherNet/IP L = POWERLINK P = PROFIBUS R = PROFINET T = EtherCAT®												
<b>Connection system I/O modules / fieldbus</b> N = basic I/O, standard I/O, extended I/O: terminal 1 = Standard I/O + M12: 3 x DI, 1 x DO E = M12: bus, 3 x DI, 1 x DO (integrated safety: N) E = STO, M12: bus, 2 x DI, 1 x DO, AI, NO, STO (integrated safety: J) F = M12: bus, 2 x DI												
<b>Integrated safety system</b> N = none J = STO (safe torque off)												
<b>Memory module</b> 2 = for motec												
<b>Degree of protection</b> P = IP65												
<b>Size</b> 1 = 063 / 071 (E84DGDVB3714 ... 1124) 2 = 080 / 090 / 100 (E84DGDVB5514 ... 1524) 3 = 080 / 090 / 100 / 112 (E84DGDVB2224 ... 3024) 4 = 080 / 090 / 100 / 112 (E84DGDVB4024 ... 7524) 5 = 132 (E84DGDVB5524 ... 7524)												

## 3.4.6

## Wall mounting without switch

	Z2	5	x	x	0	x	x	x	x	x	x	x	F
<b>Product variant</b> 8400 motec without switch - wall mounting													
<b>Type</b> 5 = not relevant													
<b>Connection technique for power terminal</b> A = cable gland B = 2 x Q4/2, Q8/0 C = Quickon, Q8/0 E = M15													
<b>Connection technique for DC 24 V</b> 0 = without A = cable gland B = Q4/2 D = M15													
<b>Brake resistor</b> 0 = without A = 220 Ohm integrated B = 90 Ohm integrated E = externally via Q5/0													
<b>Fieldbus</b> 0 = without A = AS-Interface C = CANopen G = EtherNet/IP L = POWERLINK P = PROFIBUS R = PROFINET T = EtherCAT®													
<b>I/O terminals</b> A = Basic I/O (without fieldbus) B = Standard I/O (without fieldbus) or fieldbus with STO C = fieldbus without STO D = Extended I/O (without fieldbus)													
<b>Integrated safety system</b> 0 = without STO A = with STO													
<b>Connection technique for I/O modules/fieldbus</b> A = without B = M12: DI1, DI2, DI3, DO1 C = M12: LED, bus, DI1, DI2 D = M12: LED, bus, DI1, DI2, DO1, NO, AI, STO E = M12: bus-in, bus-out, DI1, DI2 F = M12: bus-in, bus-out, DI1, DI2 DO1, NO, AI, STO G = M12: LED, bus-in, bus-out, DI1, DI2 H = M12: LED, bus-in, bus-out, DI1, DI2 DO1, NO, AI, STO I = M12: LED, bus, DI1, DI2, DI3, DO1 J = M12: bus-in, bus-out, DI1, DI2, DI3, DO1 K = M12: LED, bus-in, bus-out, DI1, DI2, DI3, DO1													
<b>Rated power</b> 215 = $10^2 \times 15 \text{ W} = 1.5 \text{ kW}$ (example)													
<b>Rated voltage</b> F = 400/480 V, 3/PE AC (also for IT systems)													

### 3.4.7 Wall mounting with switch

	Z3	5	x	x	x	x	x	x	x	x	x	x	F
<b>Product variant</b> 8400 motec with switch - wall mounting													
<b>Type</b> 5 = not relevant													
<b>Connection technique for power terminal</b> A = cable gland B = 2 x Q4/2, Q8/0													
<b>Connection technique for DC 24 V</b> 0 = without A = cable gland B = Q4/2													
<b>Service switch</b> 0 = without A = service switch B = service switch with protective function C = service switch with control elements													
<b>Brake resistor</b> 0 = without A = 220 Ohm integrated B = 90 Ohm integrated E = externally via Q5/0													
<b>Fieldbus</b> 0 = without A = AS-Interface C = CANopen L = POWERLINK G = EtherNet/IP P = PROFIBUS R = PROFINET T = EtherCAT®													
<b>I/O terminals</b> A = Basic I/O (without fieldbus) B = Standard I/O (without fieldbus) or fieldbus with STO C = fieldbus without STO D = Extended I/O (without fieldbus)													
<b>Integrated safety system</b> 0 = without STO A = with STO													
<b>Connection technique for I/O modules/fieldbus</b> A = without B = M12: DI1, DI2, DI3, DO1 C = M12: LED, bus, DI1, DI2 D = M12: LED, bus, DI1, DI2, DO1, NO, AI, STO E = M12: bus-in, bus-out, DI1, DI2 F = M12: bus-in, bus-out, DI1, DI2 DO1, NO, AI, STO G = M12: LED, bus-in, bus-out, DI1, DI2 H = M12: LED, bus-in, bus-out, DI1, DI2 DO1, NO, AI, STO I = M12: LED, bus, DI1, DI2, DI3, DO1 J = M12: bus-in, bus-out, DI1, DI2, DI3, DO1 K = M12: LED, bus-in, bus-out, DI1, DI2, DI3, DO1													
<b>Rated power</b> 215 = $10^2 \times 15 \text{ W} = 1.5 \text{ kW}$ (example)													
<b>Rated voltage</b> F = 3/PE AC 480 V													

**3.5 Overview of control terminals**

The control terminals of the 8400 motec inverters are always located in the Communication Unit.

The type of fieldbus version, power class of the inverter, or motor frame size have no influence on the availability of the device versions.

For 8400 motec **without** fieldbus link, four types of control terminals are available:

- ▶ Basic I/O
- ▶ Standard I/O
- ▶ Standard I/O + M12
  - 3 x DI and 1 x DO on M12 plugs
- ▶ Extended I/O

For 8400 motec **with** fieldbus link, four types of control terminals are available:

- ▶ Standard without safety and with the I/O functions as for the standard I/O, but without analog input and relay output
- ▶ Enhanced without safety
  - as with standard without safety
  - additionally 1 x DI and 1 x DO on M12 plug
- ▶ Standard with safety and with all I/O functions as with the standard I/O
- ▶ Enhanced with safety and all I/O functions as with the standard I/O
  - as with standard with safety
  - additionally STO, AI, 1 x DI and 1 x DO on M12 plug

Connection options for Communication Unit								
Plugs Name	X3 Fieldbus	X61 Safety	X4			Relay	X1 Holding brake	
			Digital input/output					Analog input
Type		SIA/SIB	RFR	DIx	DO1	AI/AU	COM/NO	BD1/BD2
E84DGFCNNNx	Basic I/O <sup>1)</sup>	-	1 x	2 x	-	-	✓	✓
E84DGFCNNNx	Standard I/O <sup>1)</sup>	-	1 x	5 x	✓	✓	✓	✓
E84DGFC51Nx	Standard I/O + M12 <sup>1)</sup>	-	1 x	5 x	✓	✓	✓	✓
E84DGFCXNNx	Extended I/O <sup>1)</sup>	-	1 x	8 x	✓	2 x ✓	✓	✓
<b>AS-Interface ...</b>								
E84DGFCAFNx	/ Standard I/O	-	1 x	5 x	✓	-	-	✓
E84DGFCENx	/ Enhanced I/O					-	-	
E84DGFCAFJx	STO / Standard I/O	✓				✓	✓	
E84DGFCAEJx	STO / Enhanced I/O					✓	✓	
<b>CANopen ...</b>								
E84DGFCFNx	/ Standard I/O	-	1 x	5 x	✓	-	-	✓
E84DGFCENx	/ Enhanced I/O					-	-	
E84DGFCFJx	STO / Standard I/O	✓				✓	✓	
E84DGFCCEJx	STO / Enhanced I/O					✓	✓	
<b>EtherNet/IP ...</b>								
E84DGFCGFNx	/ Standard I/O	-	1 x	5 x	✓	-	-	✓
E84DGFCGENx	/ Enhanced I/O					-	-	
E84DGFCGFJx	STO / Standard I/O	✓				✓	✓	
E84DGFCGEJx	STO / Enhanced I/O					✓	✓	
<b>POWERLINK ...</b>								
E84DGFCFLNx	/ Standard I/O	-	1 x	5 x	✓	-	-	✓
E84DGFCLENx	/ Enhanced I/O					-	-	
E84DGFCFLJx	STO / Standard I/O	✓				✓	✓	
E84DGFCLEJx	STO / Enhanced I/O					✓	✓	
<b>PROFIBUS ...</b>								
E84DGFCPFNx	/ Standard I/O	-	1 x	5 x	✓	-	-	✓
E84DGFCPENx	/ Enhanced I/O					-	-	
E84DGFCPFJx	STO / Standard I/O	✓				✓	✓	
E84DGFCPEJx	STO / Enhanced I/O					✓	✓	
<b>PROFINET ...</b>								
E84DGFCRFNx	/ Standard I/O	-	1 x	5 x	✓	-	-	✓
E84DGFCRENx	/ Enhanced I/O					-	-	
E84DGFCRFJx	STO / Standard I/O	✓				✓	✓	
E84DGFCREJx	STO / Enhanced I/O					✓	✓	
<b>EtherCAT ...</b>								
E84DGFCFTNx	/ Standard I/O	-	1 x	5 x	✓	-	-	✓
E84DGFCTENx	/ Enhanced I/O					-	-	
E84DGFCFTJx	STO / Standard I/O	✓				✓	✓	
E84DGFCTEJx	STO / Enhanced I/O					✓	✓	

- ✓ Available
- Not available
- <sup>1)</sup> Without a fieldbus link

## 4 Technical data

### General data and operating conditions

## 4 Technical data

### 4.1 General data and operating conditions

Conformity and approval			
Conformity			
CE	2014/35/EC	LowVoltage Directive	
EAC	TP TC 004/2011 (TR CU 004/2011)	On safety of low voltage equipment	Eurasian Conformity TR CU: Technical Regulation of Customs Union
EAC	TP TC 020/2011 (TR CU 020/2011)	Electromagnetic compatibility of technical means	Eurasian Conformity TR CU: Technical Regulation of Customs Union
Approval			
UR	UL 508C	Power Conversion Equipment, File No. E170350	
cUR	C22.2 No 274-13		
Approval wall mounting			
cULus	UL 508C C22.2 No 274-13	Power Conversion Equipment, File No. E132659	
Protection of persons and equipment			
Enclosure		<ul style="list-style-type: none"> <li>Seal unused bore holes for cable glands by means of blanking plugs!</li> <li>Seal unused connectors by means of protection covers or blanking plugs!</li> </ul>	
	EN 60529	8400 motec Set Wall mounting without switch	IP65
		Wall mounting with service switch / with service switch and control elements	IP54
		Wall mounting with service switch and protective function	IP64
	NEMA 250	8400 motec Set Wall mounting without switch	Type 4X (interior)
		0.37 ... 3.0 kW 4.0 ... 7.5 kW	Type 12 Type 4X (interior)
		Wall mounting with switch 0.37 ... 3.0 kW	Type 12
(Earth) leakage current	EN 61800-5-1	> 3.5 mA AC, > 10 mA DC	Observe the regulations and safety instructions!
Total fault current		In TN systems the following earth-leakage circuit breakers can be used:	
Motor mounting		0.37 ... 3.0 kW	30 mA, type B
		4.0 ... 7.5 kW, $f_{ch} = 8/16$ kHz	30 mA, type B
		4.0 ... 7.5 kW, $f_{ch} = 4$ kHz	300 mA, type B
Wall mounting and		0.37 ... 3.0 kW	30 mA, type B

Protection of persons and equipment			
Lenze system cable ≤ 3 m		4.0 ... 7.5 kW, $f_{ch} = 8/16$ kHz	30 mA, type B
		4.0 ... 7.5 kW, $f_{ch} = 4$ kHz	300 mA, type B
Wall mounting and Lenze system cable > 3 m		0.37 ... 7.5 kW	300 mA, type B
Additional equipotential bonding		M5 thread with terminal in the WU for connection of a 16 mm <sup>2</sup> PE cable	
Protective insulation of control circuits	EN 61800-5-1	Safe isolation from mains by double (reinforced) insulation	
Insulation resistance	EN 61800-5-1	<2000 m amsl: overvoltage category III >2000 m amsl: overvoltage category II	
Short-circuit strength	EN 61800-5-1	Connection:	
		Motor	To a limited extent, the controller is inhibited, error acknowledgement required
		Motor holding brake, brake resistor	No
Earth-fault strength	EN 61800-5-1	Connection:	
		Motor (at controller enable)	To a limited extent, the controller is inhibited, error acknowledgement required
		Motor (during operation)	No
		Brake resistor, PTC	No
Protective measures against		<ul style="list-style-type: none"> <li>● Short circuit on the motor side at switch-on and during operation</li> <li>● Motor stalling</li> <li>● Motor overtemperature                             <ul style="list-style-type: none"> <li>– Input for PTC or thermal contact</li> <li>– I<sup>2</sup>t monitoring</li> </ul> </li> </ul>	
Cyclic mains switching		● Switchings/minute	3
		● Switchings/hour	Max. 20
		● Switching pause	After switching the mains 3 times in one minute, there must be a switching pause of 9 minutes.
Starting current		≤ 2 × I <sub>N</sub>	

Supply conditions			
Mains connection			
Power system			
TT, TN (with an earthed neutral)		Operation permitted without restrictions.	
IT		Implement the measure described for IT systems (remove IT screw). The machine/system manufacturer is responsible for compliance with EMC requirements for noise emission (EN 61800-3) for the machine/plant! Operation with an integrated safety system is <b>not</b> permissible.	
Motor connection			
Motors	EN 60034	Only use motors suitable for inverter operation. Insulation resistance: at least $\hat{u} \geq 1.5$ kV, at least $du/dt \geq 5$ kV/ $\mu$ s	
Length of the motor cable		< 20 m (Lenze system cable, shielded)	
Ambient conditions			
Climatic			
Storage	IEC/EN 60721-3-1	1K3 (-30 ... +60 °C)	
Transport	IEC/EN 60721-3-2	2K3 (-30 ... +75 °C)	
Operation	IEC/EN 60721-3-3	3K3 (-30 ... +55 °C) Operation at 4 kHz: > +45 °C: Reduce the rated output current by 2.5 %/°C. Operation at 8/16 kHz: > +40 °C: Reduce the rated output current by 2.5 %/°C.	
Site altitude		< 4000 m amsl Above 1000 m amsl reduce the rated output current by 5 %/ 1000 m.	
Pollution	IEC/EN 61800-5-1	Degree of pollution 2	
Mechanical			
Vibration resistance (9.81 m/s <sup>2</sup> = 1 g)			
Motor mounting	Germanischer Lloyd	General conditions: Acceleration resistant up to 2 g	
	IEC/EN 60721-3-3	3M6	
Wall mounting with E84DZMAWE1	Germanischer Lloyd	General conditions: Acceleration resistant up to 2 g	
	IEC/EN 60721-3-3	3M6	
Mounting conditions			
Mounting place			
Motor mounting		Standard	
Wall mounting		With optional wall adapter	Ensure convection cooling in the niches!
Mounting position			
Wall mounting			
0.37 ... 3.0 kW		Vertically with cooling ribs at the top, rotated, horizontally	<ul style="list-style-type: none"> <li>Observe derating, see Hardware manual 8400 motec (EDS84DG752)</li> <li>Arrangement of several devices only to the sides, so that the convection cooling remains ensured!</li> </ul>
4.0 ... 7.5 kW		Optional	

<b>EMC</b>			
<b>Noise emission (in TN and TT systems)</b>			
Cable-guided	EN 61800-3		
Motor mounting		0.37 ... 1.5 kW, $f_{ch} \leq 8$ kHz	Category C1
		2.2 ... 3.0 kW, $f_{ch} \leq 4$ kHz	Category C1
		4.0 ... 7.5 kW	Category C2
Wall mounting and Lenze system cable $\leq 20$ m	EN 61800-3	0.37 ... 7.5 kW, $f_{ch} \leq 4$ kHz	Category C2
Wall mounting and Lenze system cable $\leq 10$ m	EN 61800-3	0.37 ... 7.5 kW, $f_{ch} \leq 8$ kHz	Category C2
Radiation	EN 61800-3	0.37 ... 1.5 kW, $f_{ch} \leq 8$ kHz	Category C1
		2.2 ... 7.5 kW, $f_{ch} \leq 8$ kHz	Category C2
<b>Noise immunity (according to requirements of EN 61800-3)</b>			
Electrostatic discharge (ESD)	EN 61000-4-2	8 kV with air discharge, 4 kV with contact discharge against housing	
<b>Radio frequency</b>			
Conducted	EN 61000-4-6	150 kHz ... 80 MHz, 10 V/m 80 % AM (1kHz)	
Interference (housing)	EN 61000-4-3	80 MHz ... 1000 MHz, 10 V/m 80 % AM (1kHz)	
<b>Burst</b>			
Power terminals and interfaces	EN 61000-4-4	2 kV/5 kHz	
Signal interfaces	EN 61000-4-4	1 kV/5 kHz	
Control terminals	EN 61000-4-4	2 kV/5 kHz	
<b>Surge</b>			
Power terminals	EN 61000-4-5	1.2/50 $\mu$ s, 1 kV phase/phase, 2 kV phase/PE	
Control terminals	EN 61000-4-5	1.2/50 $\mu$ s, 1 kV	
Operation on public supply systems	EN 61000-3-2 EN 61000-3-12	The devices are intended for use in an industrial environment. When being used on public network, additional measures must be taken to limit the expected radio interference. The compliance with the requirements for the machine/plant is the responsibility of the manufacturer of the machine or system!	
<b>Voltage deviations</b>			
Voltage dips	EN 61800-3	Short mains voltage dips (comp. IEC 61000-2-1) can lead to a switch-off of the motor.	

Control		
<b>Control method</b>		
	VFCplus: <ul style="list-style-type: none"> <li>● V/f control (linear or square-law)</li> </ul> VFC closed loop: <ul style="list-style-type: none"> <li>● VFCplus with additional speed feedback</li> </ul> VFC eco: <ul style="list-style-type: none"> <li>● V/f control, energetically optimised</li> </ul> SLVC: <ul style="list-style-type: none"> <li>● Sensorless vector control - torque/speed</li> </ul> SLP5M: <ul style="list-style-type: none"> <li>● Sensorless control for synchronous motors</li> </ul>	
<b>Switching frequency</b>		
	4 kHz, 8 kHz, 16 kHz	
<b>Torque behaviour</b>		
Maximum torque	1.5 x $M_{rated}$ for 60 s 2.0 x $M_{rated}$ for 3 s	if rated motor power = rated controller power
Setting range	1 : 10	SLVC: In speed range 3 ... 50 Hz V/f: In speed range 10 ... 50 Hz
<b>Sensorless vector control (speed)</b>		
Minimum output frequency	0.5 Hz (0 ... $M_{rated}$ )	
Accuracy	±0,5 %	In a setting range of 3 ... 50 Hz
Smooth running	±0.1 Hz	
<b>Output frequency</b>		
Range	-300 Hz ... +300 Hz	
Absolute resolution	0.2 Hz	
Standardised resolution	Parameter data: 0.01 %, process data: 0.006 % (= 2 <sup>14</sup> )	
<b>Digital setpoint selection</b>		
Typical accuracy	±0,01 %	
<b>Analog setpoint selection</b>		
Typical accuracy	±1 %	Based on the final value

## 4.2 Rated data

### 4.2.1 Overview

#### Input data

Mains	Voltage $U_{\text{Rated}}$ [V]	Voltage range $U_{\text{Rated}}$ [V]	Frequency range $f$ [Hz]
3/PE AC	400	320 - 0 % ... 440 + 0 %	45 - 0 % ... 65 + 0 %
3/PE AC	480	432 - 0 % ... 528 + 0 %	45 - 0 % ... 65 + 0 %

	Voltage [V]	Frequency [Hz]	Rated current [A]		Number of phases
			up to +45 °C ①	up to +55 °C ①	
E84DGDVB3714	400/480	50/60	1.3/1.1	1.0/0.8	3
E84DGDVB5514	400/480	50/60	1.8/1.5	1.4/1.1	3
E84DGDVB7514	400/480	50/60	2.4/2.0	1.8/1.5	3
E84DGDVB1124	400/480	50/60	3.2/2.7	2.4/2.0	3
E84DGDVB1524	400/480	50/60	3.8/3.1	2.9/2.3	3
E84DGDVB2224	400/480	50/60	5.6/4.6	4.2/3.5	3
E84DGDVB3024	400/480	50/60	7.2/5.9	5.4/4.4	3
E84DGDVB4024	400/480	50/60	9.3/7.7	7.0/5.8	3
E84DGDVB5524	400/480	50/60	12.8/10.6	9.6/8.0	3
E84DGDVB7524	400/480	50/60	16.3/13.5	12.3/10.1	3

① Ambient temperature, switching frequency 4 kHz

#### Output data

	Voltage [V]	Frequency [Hz]	Rated current [A]		Number of phases
			up to +45 °C ①	up to +55 °C ①	
E84DGDVB3714	0 ... 400/480	0 ... 300	1.3/1.1	1.0/0.8	3
E84DGDVB5514	0 ... 400/480	0 ... 300	1.8/1.5	1.4/1.1	3
E84DGDVB7514	0 ... 400/480	0 ... 300	2.4/2.0	1.8/1.5	3
E84DGDVB1124	0 ... 400/480	0 ... 300	3.2/2.7	2.4/2.0	3
E84DGDVB1524	0 ... 400/480	0 ... 300	3.9/3.2	2.9/2.4	3
E84DGDVB2224	0 ... 400/480	0 ... 300	5.6/4.7	4.2/3.5	3
E84DGDVB3024	0 ... 400/480	0 ... 300	7.3/6.0	5.4/4.5	3
E84DGDVB4024	0 ... 400/480	0 ... 300	9.5/7.9	7.1/5.9	3
E84DGDVB5524	0 ... 400/480	0 ... 300	13.0/10.8	9.8/8.1	3
E84DGDVB7524	0 ... 400/480	0 ... 300	16.5/13.7	12.4/10.3	3

① Ambient temperature, switching frequency 4 kHz



#### Note!

The maximally possible output voltage is approx. 94 % of the mains voltage.



#### Note!

Depending on the mounting position for wall mounting, consider derating.  
( 47)

## Power losses

Type	Power loss $P_V$ [W]	
	when operating with rated output current $I_{\text{rated}}$	when controller is inhibited
E84DGDVB3714	26	9
E84DGDVB5514	33	9
E84DGDVB7514	41	9
E84DGDVB1124	52	9
E84DGDVB1524	61	9
E84DGDVB2224	88	10
E84DGDVB3024	111	10
E84DGDVB4024	140	11
E84DGDVB5524	185	11
E84DGDVB7524	230	11

4.2.2 Operation at rated mains voltage 400 V

Mains	Voltage $U_{Lrated}$ [V]	Voltage range $U_{Lrated}$ [V]	Frequency range f [Hz]
3/PE AC	400	320 - 0 % ... 440 + 0 %	45 - 0 % ... 65 + 0 %

Type	Mains current at $I_{arated}$ $I_{Lrated}$ [A]	Output power U, V, W $S_{arated}$ [kVA]	Motor power 4 pol. ASM $P_{arated}$ [kW]
E84DGDVB3714	1.3	0.8	0.37
E84DGDVB5514	1.8	1.1	0.55
E84DGDVB7514	2.4	1.5	0.75
E84DGDVB1124	3.2	2.0	1.1
E84DGDVB1524	3.8	2.4	1.5
E84DGDVB2224	5.6	3.4	2.2
E84DGDVB3024	7.2	4.4	3.0
E84DGDVB4024	9.3	5.7	4.0
E84DGDVB5524	12.8	7.8	5.5
E84DGDVB7524	16.3	9.9	7.5

Type	Output currents [A] at switching frequency							
	2 kHz		4 kHz		8 kHz		16 kHz	
	$I_{arated2}$	$I_{aM2}$	$I_{arated4}$	$I_{aM4}$	$I_{arated8}$	$I_{aM8}$	$I_{arated16}$	$I_{aM16}$
E84DGDVB3714	-	-	1.3	2.6	1.3	2.6	0.9	1.6
E84DGDVB5514	-	-	1.8	3.6	1.8	3.6	1.2	2.2
E84DGDVB7514	-	-	2.4	4.8	2.4	4.8	1.6	2.9
E84DGDVB1124	-	-	3.2	6.4	3.2	6.4	2.1	3.8
E84DGDVB1524	-	-	3.9	7.8	3.9	7.8	2.6	4.7
E84DGDVB2224	-	-	5.6	11.2	5.6	11.2	3.7	6.7
E84DGDVB3024	-	-	7.3	14.6	7.3	14.6	4.9	8.8
E84DGDVB4024	-	-	9.5	19.0	9.5	19.0	6.3	11.4
E84DGDVB5524	-	-	13.0	26.0	13.0	26.0	8.7	15.6
E84DGDVB7524	-	-	16.5	33.0	16.5	33.0	11.0	19.8

$I_{aNx}$   
 $I_{aMx}$

Rated value of continuous output current  
Maximum output current (overload current)  

- Periodic load change of 3 s with  $I_{aMx}$  and recovery time of 12 s according to the tables under chapter 4.4
- Can be obtained in the setting "x kHz fixed/..." in C00018

Switching frequency

If the maximum heatsink temperature is reached, the switching frequency is reduced to 4 kHz.  
In the setting "x kHz var./..." in C00018 the switching frequency is reduced depending on the output current.  
Depending on the switching frequency and e.g. the ambient temperature, it may be required to reduce the output current (chapter 4.1, operating conditions).

## Fuses and cable cross-sections

## ► Point-to-point connection - direct wiring of the mains voltage - typical fusing

Operation								
Type	Installation according to EN 60204-1 <sup>1)</sup>					Installation according to UL <sup>2)</sup>		FI <sup>3)</sup> [mA]
	①	②	L1, L2, L3 - laying system			③	L1, L2, L3	
	[A]	[A]	B2 [mm <sup>2</sup> ]	C [mm <sup>2</sup> ]	F [mm <sup>2</sup> ]	[A]	[AWG]	
E84DGDVB3714	C 16	16	2.5	-	-	15	12	≥ 30
E84DGDVB5514	C 16	16	2.5	-	-	15	12	≥ 30
E84DGDVB7514	C 16	16	2.5	-	-	15	12	≥ 30
E84DGDVB1124	C 16	16	2.5	-	-	15	12	≥ 30
E84DGDVB1524	C 16	16	2.5	-	-	15	12	≥ 30
E84DGDVB2224	C 16	16	2.5	-	-	15	12	≥ 30
E84DGDVB3024	C 16	16	2.5	-	-	15	12	≥ 30
E84DGDVB4024	C20	20	4.0	-	-	20	12	≥ 30
E84DGDVB5524	C20	20	4.0	-	-	20	12	≥ 30
E84DGDVB7524	C 20	20	4.0	-	-	20	12	≥ 30

## ► Multiple connection - loop-through connection of the mains voltage - maximum fusing

Operation								
Type	Installation according to EN 60204-1 <sup>1)</sup>					Installation according to UL <sup>2)</sup>		FI <sup>3)</sup> [mA]
	①	②	L1, L2, L3 - laying system			③	L1, L2, L3	
	[A]	[A]	B2 [mm <sup>2</sup> ]	C [mm <sup>2</sup> ]	F [mm <sup>2</sup> ]	[A]	[AWG]	
E84DGDVB3714	C 32	32	6.0	-	-	15	12	≥ 30
E84DGDVB5514	C 32	32	6.0	-	-	15	12	≥ 30
E84DGDVB7514	C 32	32	6.0	-	-	15	12	≥ 30
E84DGDVB1124	C 32	32	6.0	-	-	15	12	≥ 30
E84DGDVB1524	C 32	32	6.0	-	-	15	12	≥ 30
E84DGDVB2224	C 32	32	6.0	-	-	25	10	≥ 30
E84DGDVB3024	C 32	32	6.0	-	-	25	10	≥ 30
E84DGDVB4024	C 50	50	16.0	-	-	50	6	≥ 30
E84DGDVB5524	C 50	50	16.0	-	-	50	6	≥ 30
E84DGDVB7524	C 50	50	16.0	-	-	50	6	≥ 30

1) The data are recommendations. Other designs/laying systems can be implemented (e.g. in accordance with VDE 0298-4). The cable cross-sections apply under the following conditions: Use of PVC-insulated copper cables, conductor temperature < 70 °C, ambient temperature < 45°C, no bundling of cables or cores, three loaded cores.

2) Only use UL-approved cables, fuses and fuse holders.

UL fuse: voltage ≤ 500 V, tripping characteristic for instance "CC". The cable cross-sections apply under the following conditions: conductor temperature < 75 °C, ambient temperature < 45°C.

3) Universal-current sensitive earth-leakage circuit breaker, short-time delayed

① Circuit breaker

② Fuse of gG/gL utilisation category or semiconductor fuses of gRL utilisation category

③ Fuse

Observe national and regional regulations

### 4.2.3 Operation with increased power at a 400 V mains

In continuous operation, the controllers can be actuated with a more powerful motor. The overload capacity is limited to 120 %. Typical applications are pumps with a quadratic load characteristic, or fans.



**Note!**

Operation with an increased rated power is only permitted ...

- ▶ with the rated data specified for the controller.
- ▶ within the mains voltage range specified.
- ▶ with the switching frequency 4 kHz.
- ▶ at a max. ambient temperature of 40 °C
- ▶ with the fuses and cable cross-sections specified for this operation.
- ▶ after parameterisation according to the specifications (cf. EDS84DM... software manual)

Mains	Voltage $U_{Lrated}$ [V]	Voltage range $U_{Lrated}$ [V]	Frequency range $f$ [Hz]
3/PE AC	400	320 - 0 % ... 440 + 0 %	45 - 0 % ... 65 + 0 %

Type	Mains current at $I_{rated}$ $I_{Lrated}$ [A]	Output power $U, V, W$ $S_{rated}$ [kVA]	Motor power 4 pol. ASM $P_{rated}$ [kW]
E84DGDVB3714	1.6	1.0	0.55
E84DGDVB5514	2.2	1.3	0.75
E84DGDVB7514	3.0	1.8	1.1
E84DGDVB1124	3.8	2.4	1.5
E84DGDVB1524 <sup>1)</sup>	4.6	3.0	1.8
E84DGDVB2224	6.7	4.1	2.2
E84DGDVB3024 <sup>1)</sup>	8.6	5.3	4.0
E84DGDVB4024	11.3	6.8	5.5
E84DGDVB5524	15.3	9.4	7.5
E84DGDVB7524 <sup>2)</sup>	19.5	11.9	9.2

1) Operation with increased rated power for motor mounting only.

2) Motor connection with plug (Q8) not permissible.

Type	Output currents [A] at switching frequency							
	2 kHz		4 kHz		8 kHz		16 kHz	
	$I_{\text{arated2}}$	$I_{\text{aM2}}$	$I_{\text{arated4}}$	$I_{\text{aM4}}$	$I_{\text{arated8}}$	$I_{\text{aM8}}$	$I_{\text{arated16}}$	$I_{\text{aM16}}$
E84DGDVB3714	-	-	1.6	2.6	-	-	-	-
E84DGDVB5514	-	-	2.2	3.6	-	-	-	-
E84DGDVB7514	-	-	3.0	4.8	-	-	-	-
E84DGDVB1124	-	-	3.8	6.4	-	-	-	-
E84DGDVB1524 <sup>1)</sup>	-	-	4.8	7.8	-	-	-	-
E84DGDVB2224	-	-	6.7	11.2	-	-	-	-
E84DGDVB3024 <sup>1)</sup>	-	-	8.7	14.6	-	-	-	-
E84DGDVB4024	-	-	11.6	19.0	-	-	-	-
E84DGDVB5524	-	-	15.6	26.0	-	-	-	-
E84DGDVB7524 <sup>2)</sup>	-	-	19.8	33.0	-	-	-	-

1) Operation with increased rated power for motor mounting only.

2) Motor connection with plug (Q8) not permissible.

$I_{\text{aNx}}$   
 $I_{\text{aMx}}$

Rated value of continuous output current

Maximum output current (overload current)

- Periodic load change of 3 s with  $I_{\text{aMx}}$  and recovery time of 12 s according to the tables under chapter  4.4

### Fuses and cable cross-sections

The data/recommendations for operation on a rated mains voltage 400 V can be applied.

 40)

4.2.4 Operation with rated mains voltage 480 V

Mains	Voltage $U_{Lrated}$ [V]	Voltage range $U_{Lrated}$ [V]	Frequency range $f$ [Hz]
3/PE AC	480	432 - 0 % ... 528 + 0 %	45 - 0 % ... 65 + 0 %

Type	Mains current at $I_{arated}$ $I_{Lrated}$ [A]	Output power $U, V, W$ $S_{arated}$ [kVA]	Motor power 4 pol. ASM $P_{arated}$ [kW]
E84DGDVB3714	1.1	0.8	0.37
E84DGDVB5514	1.5	1.1	0.55
E84DGDVB7514	2.0	1.5	0.75
E84DGDVB1124	2.7	2.1	1.1
E84DGDVB1524	3.1	2.4	1.5
E84DGDVB2224	4.6	3.5	2.2
E84DGDVB3024	5.9	4.5	3.0
E84DGDVB4024	7.7	5.7	4.0
E84DGDVB5524	10.6	7.9	5.5
E84DGDVB7524	13.5	10.0	7.5

Type	Output currents [A] at switching frequency							
	2 kHz		4 kHz		8 kHz		16 kHz	
	$I_{arated2}$	$I_{aM2}$	$I_{arated4}$	$I_{aM4}$	$I_{arated8}$	$I_{aM8}$	$I_{arated16}$	$I_{aM16}$
E84DGDVB3714	-	-	1.1	2.2	1.1	2.2	0.7	1.3
E84DGDVB5514	-	-	1.5	3.0	1.5	3.0	1.0	1.8
E84DGDVB7514	-	-	2.0	4.0	2.0	4.0	1.3	2.4
E84DGDVB1124	-	-	2.7	5.4	2.7	5.4	1.8	3.2
E84DGDVB1524	-	-	3.2	6.4	3.2	6.4	2.1	3.8
E84DGDVB2224	-	-	4.7	9.4	4.7	9.4	3.1	5.6
E84DGDVB3024	-	-	6.0	12.0	6.0	12.0	4.0	7.2
E84DGDVB4024	-	-	7.9	15.8	7.9	15.8	5.3	9.5
E84DGDVB5524	-	-	10.8	21.6	10.8	21.6	7.2	13.0
E84DGDVB7524	-	-	13.7	27.4	13.7	27.4	9.1	16.4

$I_{aNx}$   
 $I_{aMx}$

Rated value of continuous output current  
Maximum output current (overload current)  

- Periodic load change of 3 s with  $I_{aMx}$  and recovery time of 12 s according to the tables under chapter 4.4
- Can be obtained in the setting "x kHz fixed/..." in C00018

Switching frequency

If the maximum heatsink temperature is reached, the switching frequency is reduced to 4 kHz.  
In the setting "x kHz var./..." in C00018 the switching frequency is reduced depending on the output current.  
Depending on the switching frequency and e.g. the ambient temperature, it may be required to reduce the output current (chapter 4.1, operating conditions).

## Fuses and cable cross-sections

## ► Point-to-point connection - direct wiring of the mains voltage - typical fusing

Operation								
Type	Installation according to EN 60204-1 <sup>1)</sup>					Installation according to UL <sup>2)</sup>		FI <sup>3)</sup> [mA]
	①	②	L1, L2, L3 - laying system			③	L1, L2, L3	
	[A]	[A]	B2 [mm <sup>2</sup> ]	C [mm <sup>2</sup> ]	F [mm <sup>2</sup> ]	[A]	[AWG]	
E84DGDVB3714	C 16	16	2.5	-	-	15	12	≥ 30
E84DGDVB5514	C 16	16	2.5	-	-	15	12	≥ 30
E84DGDVB7514	C 16	16	2.5	-	-	15	12	≥ 30
E84DGDVB1124	C 16	16	2.5	-	-	15	12	≥ 30
E84DGDVB1524	C 16	16	2.5	-	-	15	12	≥ 30
E84DGDVB2224	C 16	16	2.5	-	-	15	12	≥ 30
E84DGDVB3024	C 16	16	2.5	-	-	15	12	≥ 30
E84DGDVB4024	C 20	20	4.0	-	-	20	12	≥ 30
E84DGDVB5524	C 20	20	4.0	-	-	20	12	≥ 30
E84DGDVB7524	C 20	20	4.0	-	-	20	12	≥ 30

## ► Multiple connection - loop-through connection of the mains voltage - maximum fusing

Operation								
Type	Installation according to EN 60204-1 <sup>1)</sup>					Installation according to UL <sup>2)</sup>		FI <sup>3)</sup> [mA]
	①	②	L1, L2, L3 - laying system			③	L1, L2, L3	
	[A]	[A]	B2 [mm <sup>2</sup> ]	C [mm <sup>2</sup> ]	F [mm <sup>2</sup> ]	[A]	[AWG]	
E84DGDVB3714	C 32	32	6.0	-	-	15	12	≥ 30
E84DGDVB5514	C 32	32	6.0	-	-	15	12	≥ 30
E84DGDVB7514	C 32	32	6.0	-	-	15	12	≥ 30
E84DGDVB1124	C 32	32	6.0	-	-	15	12	≥ 30
E84DGDVB1524	C 32	32	6.0	-	-	15	12	≥ 30
E84DGDVB2224	C 32	32	6.0	-	-	25	10	≥ 30
E84DGDVB3024	C 32	32	6.0	-	-	25	10	≥ 30
E84DGDVB4024	C 50	50	16.0	-	-	50	6	≥ 30
E84DGDVB5524	C 50	50	16.0	-	-	50	6	≥ 30
E84DGDVB7524	C 50	50	16.0	-	-	50	6	≥ 30

1) The data are recommendations. Other designs/laying systems can be implemented (e.g. in accordance with VDE 0298-4). The cable cross-sections apply under the following conditions: Use of PVC-insulated copper cables, conductor temperature < 70 °C, ambient temperature < 45 °C, no bundling of cables or cores, three loaded cores.

2) Only use UL-approved cables, fuses and fuse holders.

UL fuse: voltage ≤ 500 V, tripping characteristic for instance "CC". The cable cross-sections apply under the following conditions: conductor temperature < 75 °C, ambient temperature < 45 °C.

3) Universal-current sensitive earth-leakage circuit breaker, short-time delayed

① Circuit breaker

② Fuse of gG/gL utilisation category or semiconductor fuses of gRL utilisation category

③ Fuse

Observe national and regional regulations

### 4.2.5 Operation with increased power on a 480 V system

In continuous operation, the controllers can be actuated with a more powerful motor. The overload capacity is limited to 120 %. Typical applications are pumps with a quadratic load characteristic, or fans.



**Note!**

Operation with an increased rated power is only permitted ...

- ▶ with the rated data specified for the controller.
- ▶ within the mains voltage range specified.
- ▶ with the switching frequency 4 kHz.
- ▶ at a max. ambient temperature of 40 °C
- ▶ with the fuses and cable cross-sections specified for this operation.
- ▶ after parameterisation according to the specifications (cf. EDS84DM... software manual)

Mains	Voltage $U_{Lrated}$ [V]	Voltage range $U_{Lrated}$ [V]	Frequency range f [Hz]
3/PE AC	480	432 - 0 % ... 528 + 0 %	45 - 0 % ... 65 + 0 %

Type	Mains current at $I_{Lrated}$ $I_{Lrated}$ [A]	Output power U, V, W $S_{Lrated}$ [kVA]	Motor power 4 pol. ASM $P_{Lrated}$ [kW]
E84DGDVB3714	1.3	1.0	0.55
E84DGDVB5514	1.8	1.3	0.75
E84DGDVB7514	2.4	1.8	1.1
E84DGDVB1124	3.2	2.4	1.5
E84DGDVB1524 <sup>1)</sup>	3.8	3.0	1.8
E84DGDVB2224	5.6	4.1	2.2
E84DGDVB3024 <sup>1)</sup>	7.2	5.3	4.0
E84DGDVB4024	9.3	6.8	5.5
E84DGDVB5524	12.8	9.4	7.5
E84DGDVB7524 <sup>2)</sup>	16.3	11.9	9.2

1) Operation with increased rated power for motor mounting only.

2) Motor connection with plug (Q8) not permissible.

Type	Output currents [A] at switching frequency							
	2 kHz		4 kHz		8 kHz		16 kHz	
	$I_{\text{arated2}}$	$I_{\text{aM2}}$	$I_{\text{arated4}}$	$I_{\text{aM4}}$	$I_{\text{arated8}}$	$I_{\text{aM8}}$	$I_{\text{arated16}}$	$I_{\text{aM16}}$
E84DGDVB3714	-	-	1.3	2.2	-	-	-	-
E84DGDVB5514	-	-	1.8	3.0	-	-	-	-
E84DGDVB7514	-	-	2.4	4.0	-	-	-	-
E84DGDVB1124	-	-	3.2	5.4	-	-	-	-
E84DGDVB1524 <sup>1)</sup>	-	-	3.8	6.4	-	-	-	-
E84DGDVB2224	-	-	5.6	9.4	-	-	-	-
E84DGDVB3024 <sup>1)</sup>	-	-	7.2	12.0	-	-	-	-
E84DGDVB4024	-	-	9.5	15.8	-	-	-	-
E84DGDVB5524	-	-	13.0	21.6	-	-	-	-
E84DGDVB7524 <sup>2)</sup>	-	-	16.4	33.0	-	-	-	-

1) Operation with increased rated power for motor mounting only.

2) Motor connection with plug (Q8) not permissible.

$I_{\text{aNx}}$   
 $I_{\text{aMx}}$

Rated value of continuous output current

Maximum output current (overload current)

- Periodic load change of 3 s with  $I_{\text{aMx}}$  and recovery time of 12 s according to the tables under chapter  4.4

### Fuses and cable cross-sections

The data/recommendations for operation at a rated mains voltage of 480 V can be applied.

 40)

### 4.3 Device protection by current derating

In order to protect the devices, the utilisation degree  $I/I_{aNx}$  is limited for wall mounting and depends on the following:

- ▶ mounting arrangement
  - vertical, horizontal, lying, hanging
- ▶ ambient temperature  $T$
- ▶ rated power of the device according to the type designation
- ▶ switching frequency  $f_{ch}$
- ▶ selected operating mode
  - operation with rated data up to  $\leq 100\% I/I_{aNx}$
  - operation with increased power  $\leq 120\% I/I_{aNx}$

The utilisation limits are shown in diagrams.

#### 4.3.1 Wall mounting without switch

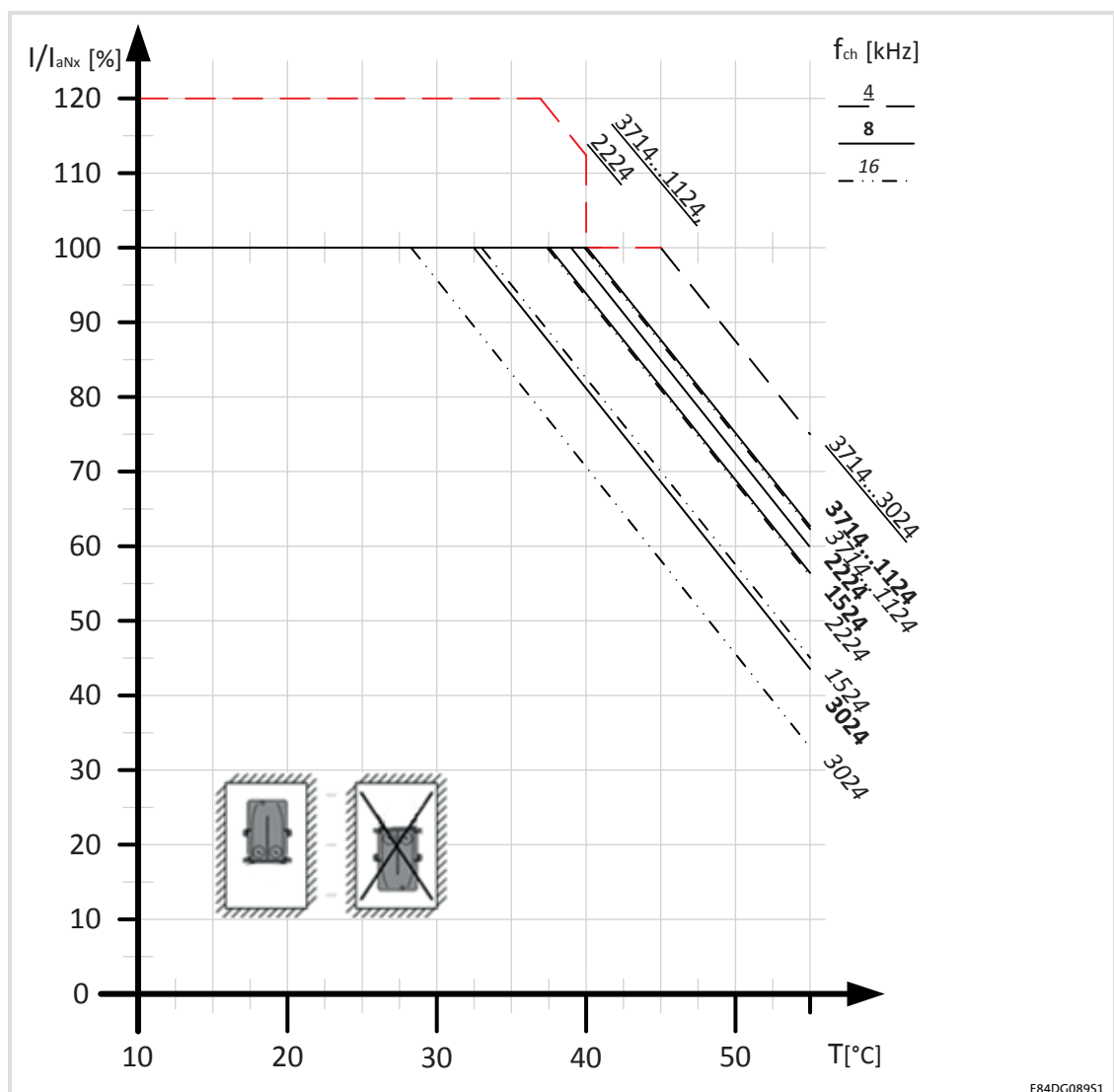

**Technical data**

Device protection by current derating  
 Wall mounting without switch

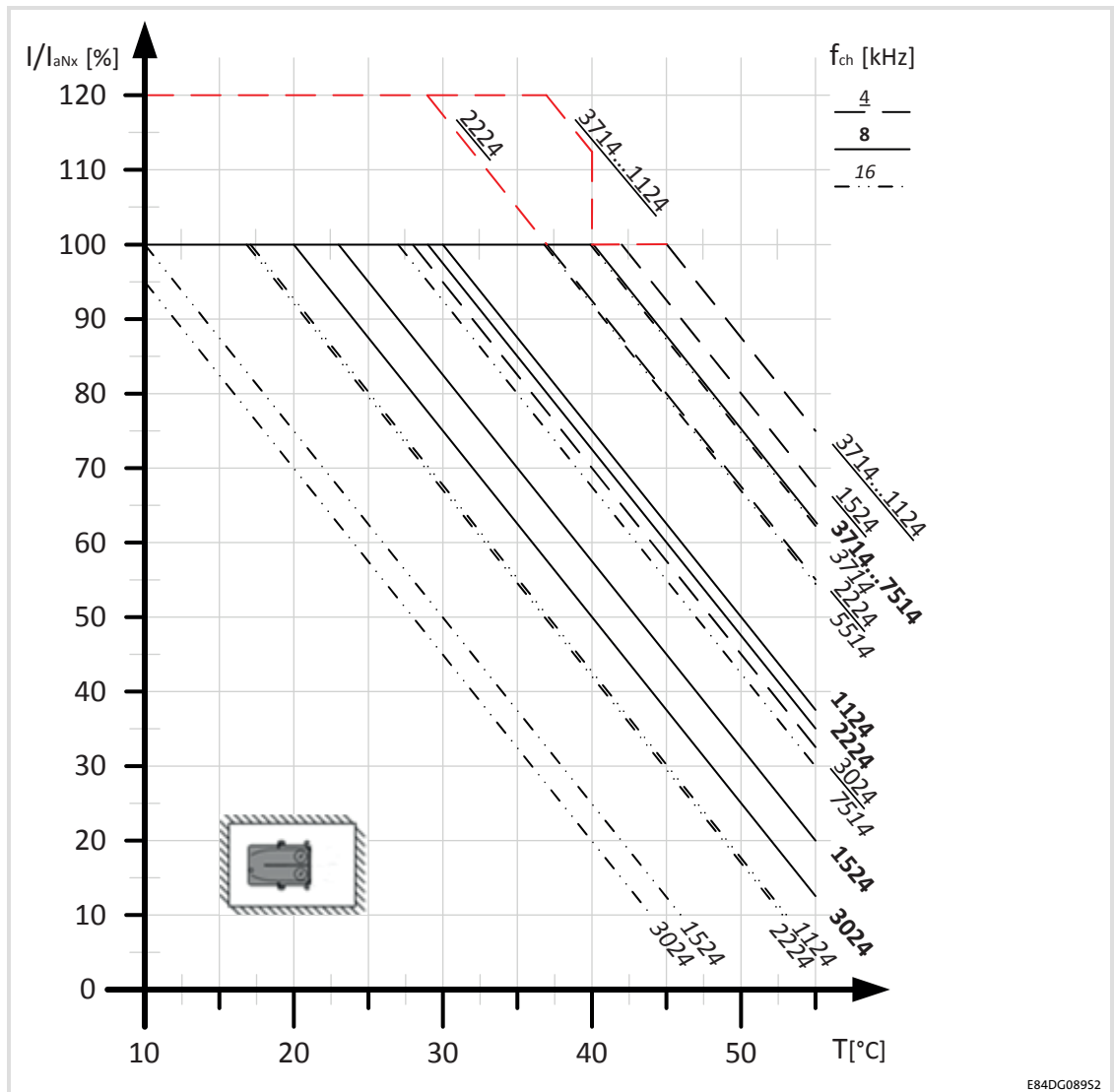

E84DG08952

Device protection by current derating  
Wall mounting without switch

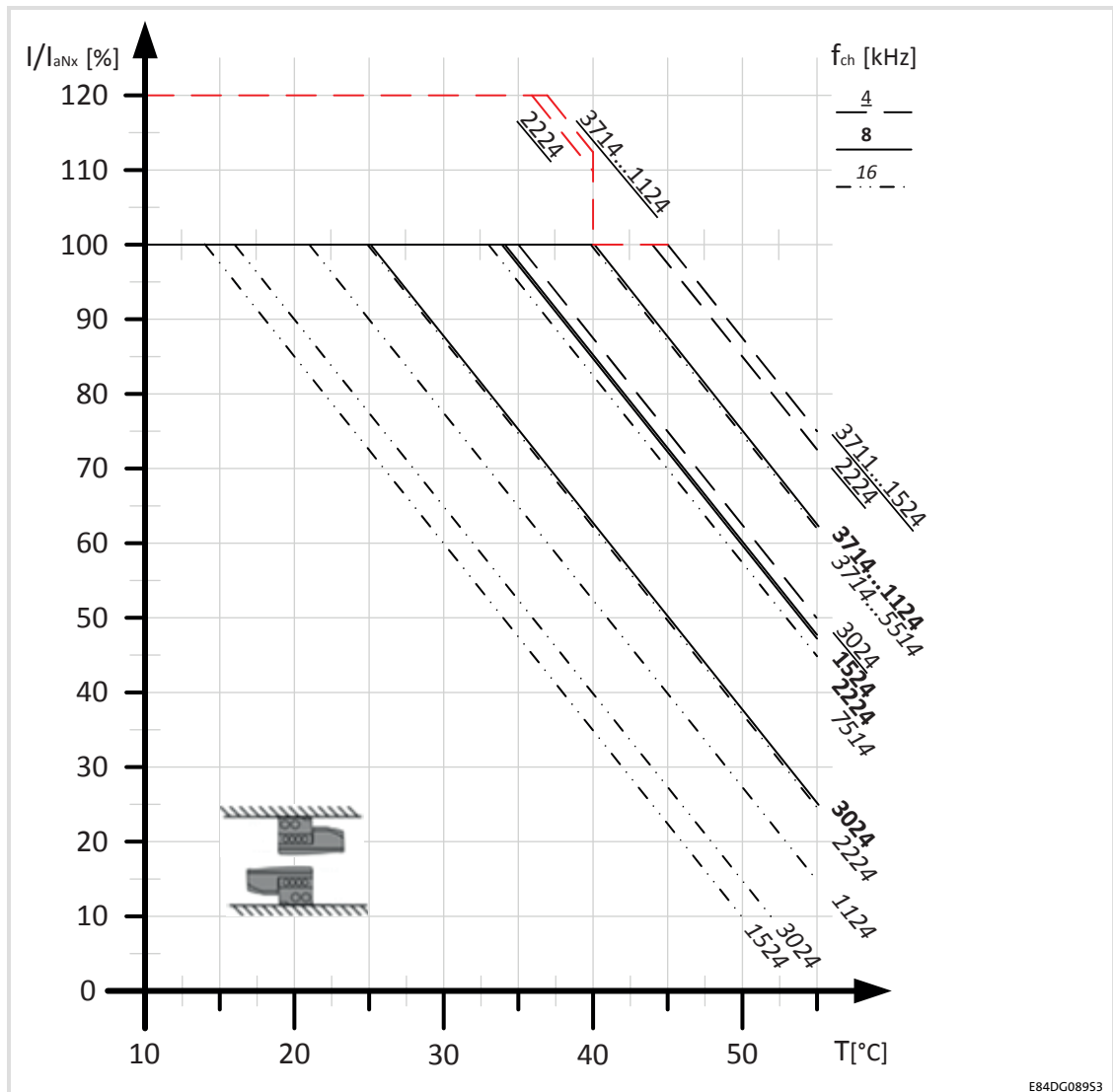

E84DG08953

4.3.2

Wall mounting with switch

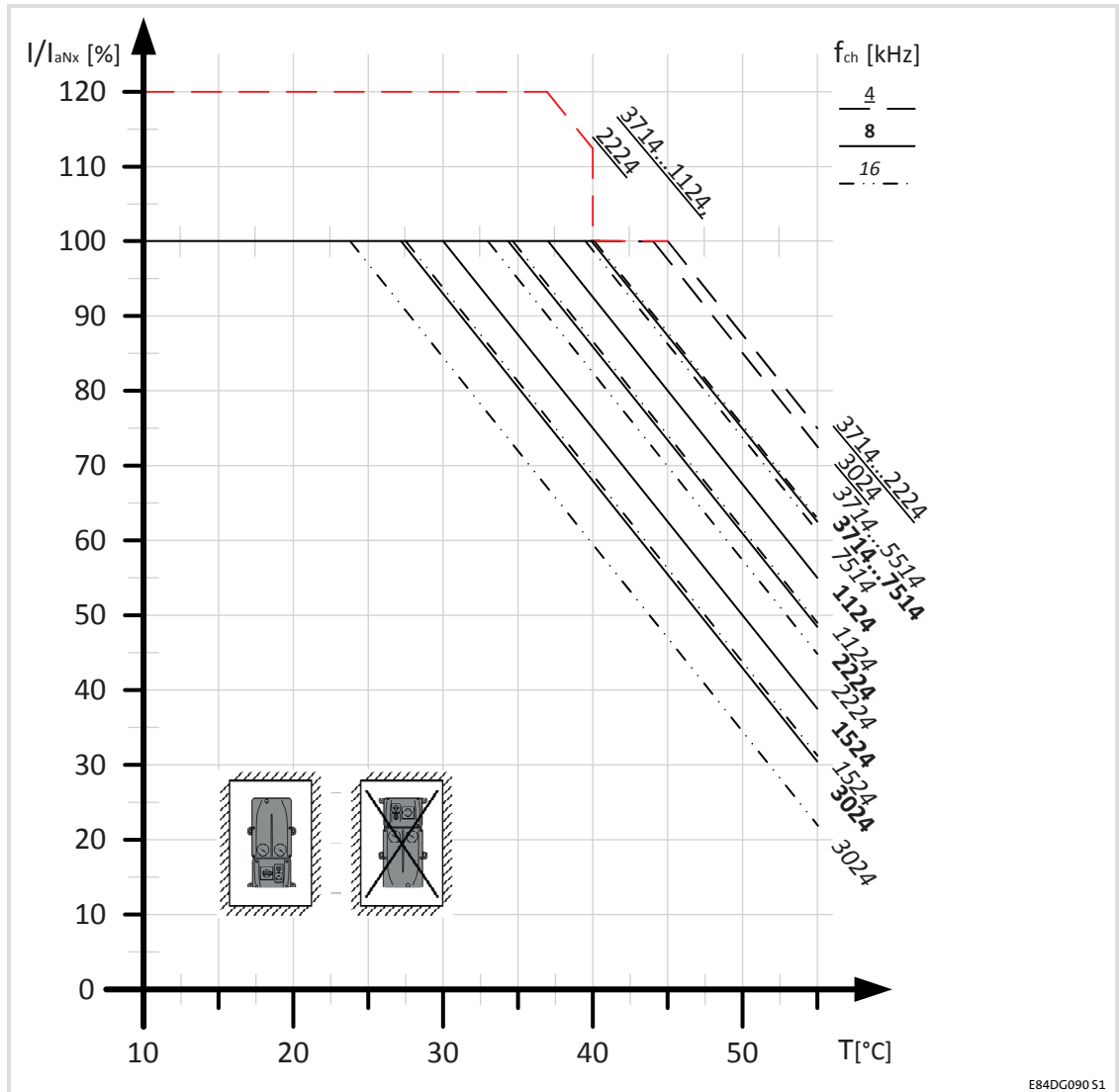

E84DG090 51

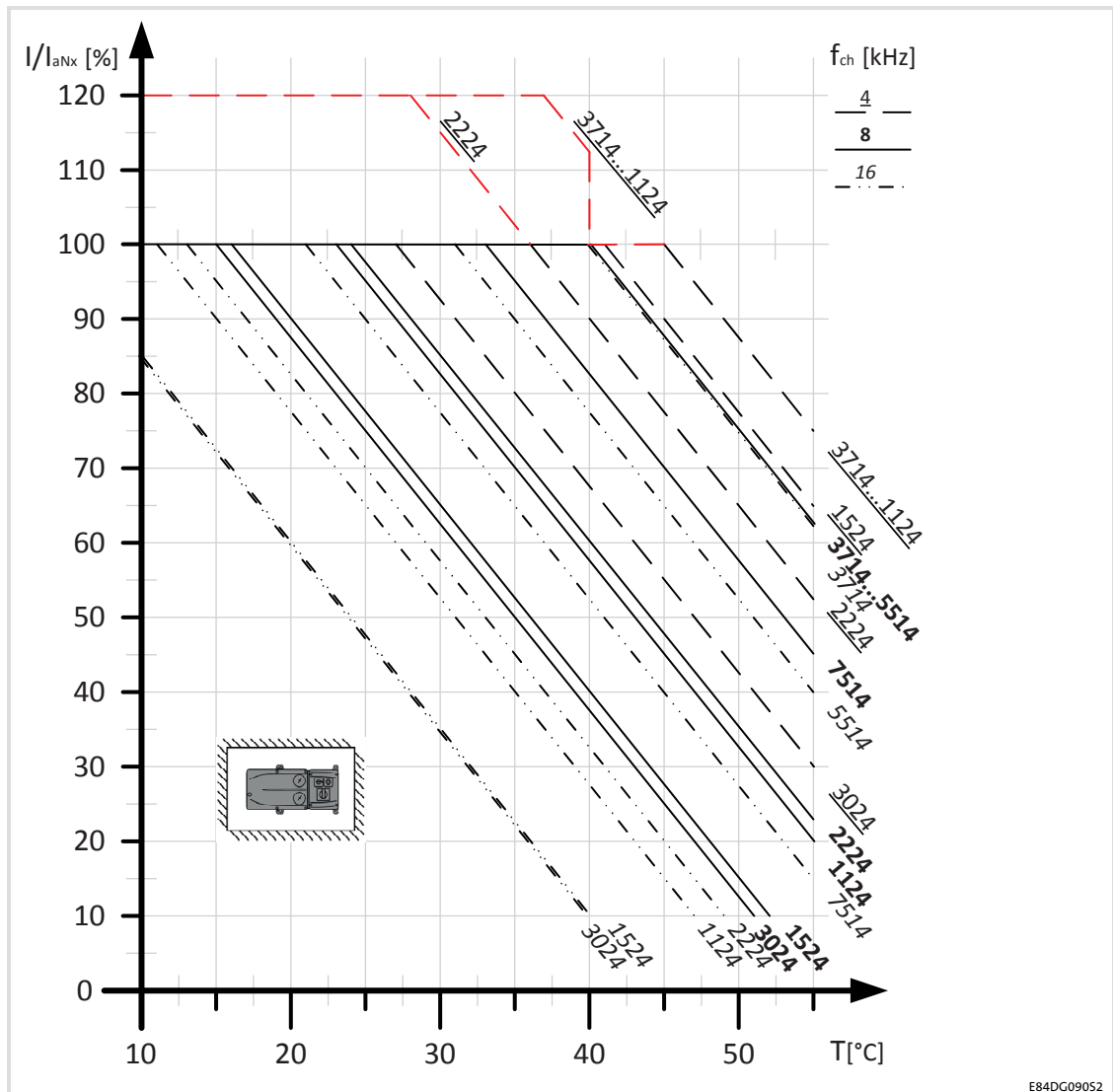

E84DG09052

**Technical data**

Device protection by current derating  
Wall mounting with switch

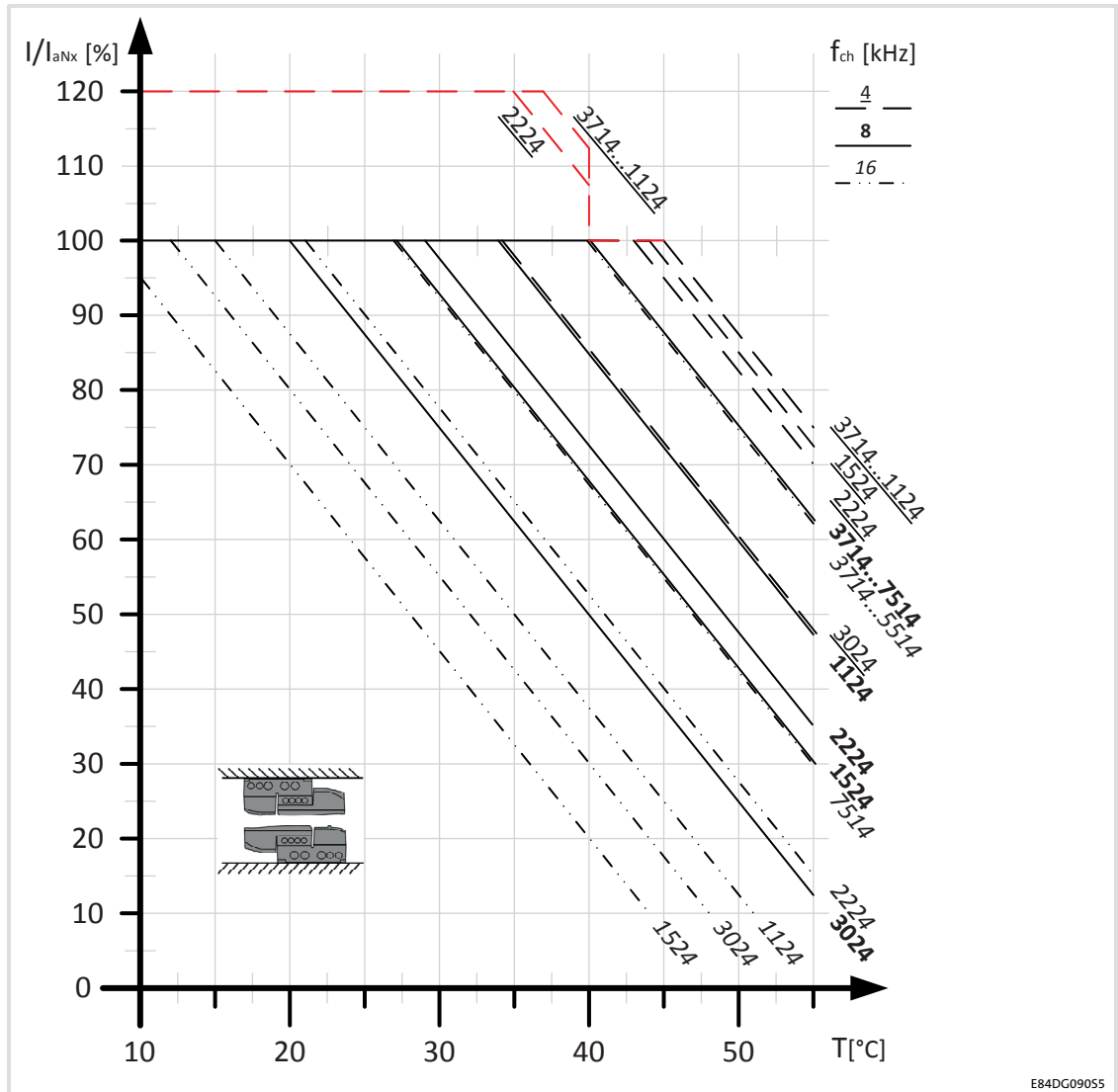

E84DG09055

#### 4.4 Overcurrent operation

If the device utilisation  $I_{xt}$  exceeds the threshold set (C00064/1, Lenze setting = 100 %), the monitoring function triggers an error response and sets the controller to the "Fault" device status. To exit the device status, the error must be reset ("acknowledged") explicitly.

The curves of typical load functions and the simulation of the "Ixt" function are shown in the following illustration:

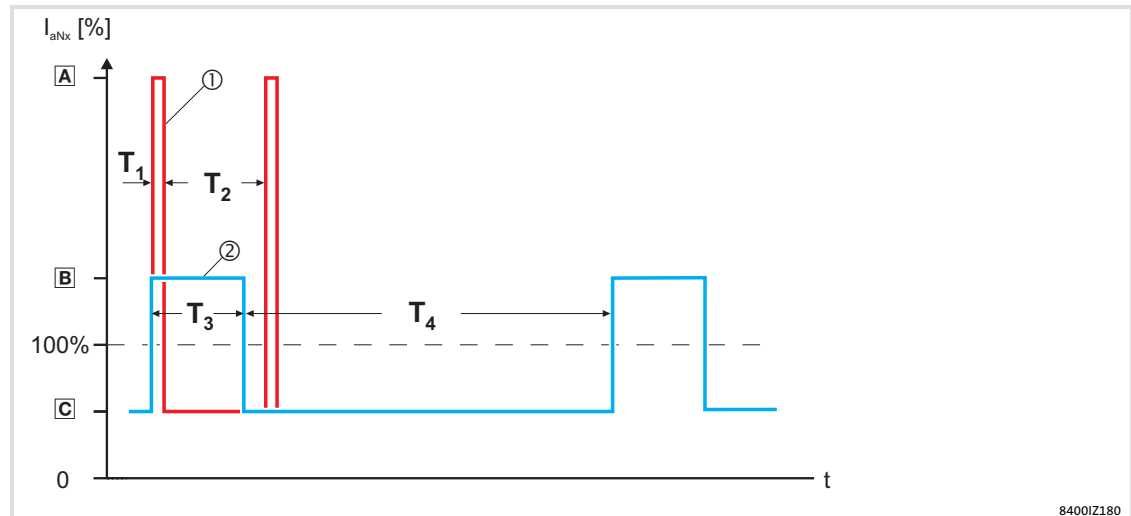

Fig. 4-1 Overcurrent capacity at 45° C

- ① Pulse utilisation (15 s cycle)
  - Ⓐ Peak current
  - Ⓒ Unloading current
  - $T_1$  Peak current period
  - $T_2$  Unloading current period
- ② Permanent load (180 s cycle)
  - Ⓑ Peak current
  - Ⓒ Unloading current
  - $T_3$  Peak current period
  - $T_4$  Unloading current period
  - $I_{aNx}$  Rated value of continuous output current

#### Calculation for pulse utilisation ①

Output frequency >5 Hz E84DGDVB3714 ... 7524	Output frequency <5 Hz	
	E84DGDVB3714 ... 1524	E84DGDVB2224 ... 7524
$\frac{A \cdot T_1 + C \cdot T_2}{T_1 + T_2} \leq 100\%$	$\frac{A \cdot T_1 + C \cdot T_2}{T_1 + T_2} \leq 75\%$	$\frac{A \cdot T_1 + C \cdot T_2}{T_1 + T_2} \leq 50\%$

#### Calculation for permanent utilisation ②

Output frequency >5 Hz E84DGDVB3714 ... 7524	Output frequency <5 Hz	
	E84DGDVB3714 ... 1524	E84DGDVB2224 ... 7524
$\frac{B \cdot T_3 + C \cdot T_4}{T_3 + T_4} \leq 100\%$	$\frac{B \cdot T_3 + C \cdot T_4}{T_3 + T_4} \leq 75\%$	$\frac{B \cdot T_3 + C \cdot T_4}{T_3 + T_4} \leq 50\%$

Type	$I_{amax}/I_{aN8}$ [%] in 15-s cycle ①							
	f = 2 kHz		f = 4 kHz		f = 8 kHz		f = 16 kHz	
	A	B	A	B	A	B	A	B
E84DGDVB3714								
E84DGDVB5514								
E84DGDVB7514								
E84DGDVB1124								
E84DGDVB1524								
E84DGDVB2224	-	-	200	75	200	75	120	50
E84DGDVB3024								
E84DGDVB4024								
E84DGDVB5524								
E84DGDVB7524								

Type	$I_{amax}/I_{aN8}$ [%] in 180-s cycle ②							
	f = 2 kHz		f = 4 kHz		f = 8 kHz		f = 16 kHz	
	C	D	C	D	C	D	C	D
E84DGDVB3714								
E84DGDVB5514								
E84DGDVB7514								
E84DGDVB1124								
E84DGDVB1524								
E84DGDVB2224	-	-	150	75	150	75	100	50
E84DGDVB3024								
E84DGDVB4024								
E84DGDVB5524								
E84DGDVB7524								



#### Tip!

For calculations of application-specific cycles please contact your Lenze contact person.

#### 4.5 Switching frequency reduction

Under certain operating conditions, the maximum output current is limited for all devices:

- ▶ When the maximum heatsink temperature is exceeded, the controller switches from 16 kHz to 8 kHz and from 8 kHz to 4 kHz, irrespective of the switching frequency mode. This function can be deactivated via C00144.

If the heatsink temperature increases above 105 °C, the controller is inhibited and the error message "OH1: Heatsink overtemperature" is output.

The error response is also triggered when the switching frequency reduction is deactivated.

## 4

### Technical data

Power terminals

8400 motec 0.37 ... 3 kW

### 4.6

#### Power terminals

#### 4.6.1

#### 8400 motec 0.37 ... 3 kW

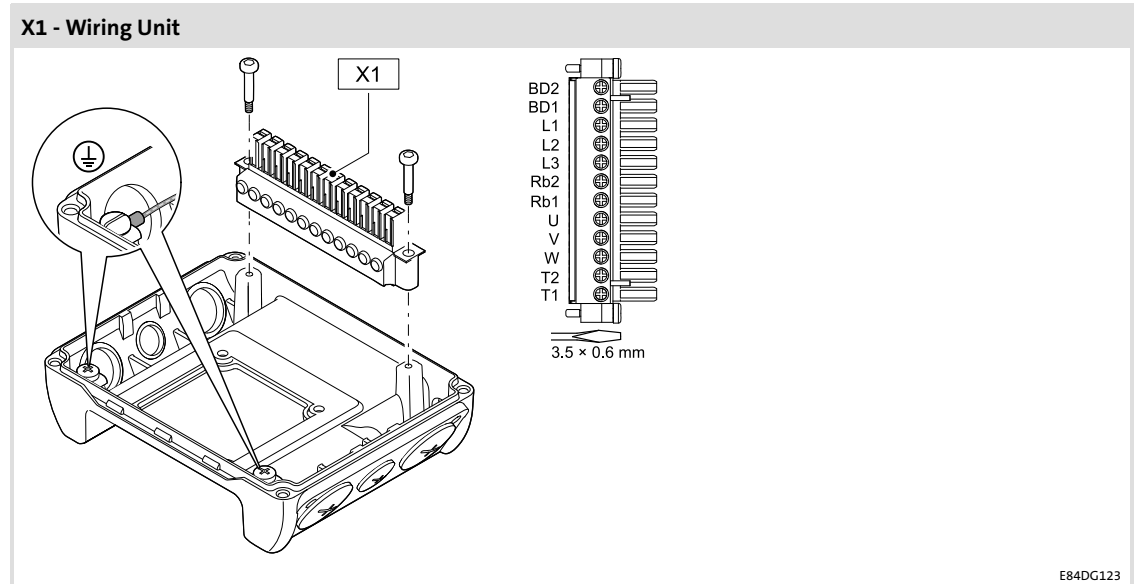

E84DG123

### Mains

Terminal data				
Name	Power	Conductor cross-section [mm <sup>2</sup> ] [AWG]	Tightening torque [Nm] [lb-in]	
X1				
L1, L2, L3	0.37 ... 1.5 kW	1 ... 4 18 ... 10	0.5 4.4	3.5 x 0.6
		2 x 0.5 ... 2 x 2.5 <sup>1)</sup> 18 ... 10		
	2.2 ... 3.0 kW	1 ... 6 18 ... 8	0.8 7.0	3.5 x 0.6
		2 x 0.5 ... 2 x 2.5 <sup>1)</sup> 18 ... 8		
⊕				
PE	0.37 ... 1.5 kW	1 ... 4 18 ... 10	1.7 16	8 x 1.2
		2.2 ... 3.0 kW	1.7 16	8 x 1.2

<sup>1)</sup> For looping-through connections (daisy chain) => two conductors with TWIN wire end ferrule

Features		
Name	Description	Rated value
X1		
L1, L2, L3	Mains phases	See rated data

## Motor

Terminal data				
Name	Power	Conductor cross-section [mm <sup>2</sup> ] [AWG]	Tightening torque [Nm] [lb-in]	
X1				
U, V, W	0.37 ... 1.5 kW	1 ... 4 18 ... 10	0.5 4.4	3.5 x 0.6
	2.2 ... 3.0 kW	1 ... 6 18 ... 8	0.8 7.0	
⊕				
PE	0.37 ... 1.5 kW	1 ... 4 18 ... 10	1.7 16	8 x 1.2
	2.2 ... 3.0 kW	1 ... 6 18 ... 8	1.7 16	

Features		
Name	Description	Rated value
X1		
U, V, W	Motor phases	See rated data

## Motor temperature monitoring



### Danger!

#### Hazardous electrical voltage

Terminals T1, T2 are on DC-bus voltage potential.

#### Possible consequences:

- ▶ Death or severe injuries when touching the power terminals.

#### Protective measures:

- ▶ Before working on the terminals, disconnect mains and wait for at least 3 minutes.
- ▶ Check whether the terminals are deenergised.

Terminal data				
Name	Power	Conductor cross-section [mm <sup>2</sup> ] [AWG]	Tightening torque [Nm] [lb-in]	
X1				
T1, T2	0.37 ... 1.5 kW	1.5 16	0.5 4.4	3.5 x 0.6
	2.2 ... 3.0 kW	1 ... 6 18 ... 8	0.8 7.0	

Features		
Name	Description	Rated value
X1		
T1, T2	Motor temperature monitoring	See rated data <b>Danger! Hazardous electrical voltage.</b> • T1 and T2 have DC-bus voltage potential .

## Motor holding brake

Terminal data				
Name	Power	Conductor cross-section [mm <sup>2</sup> ] [AWG]	Tightening torque [Nm] [lb-in]	
X1				
BD1 (+)	–	1.5	0.5	3.5 x 0.6
BD2 (-)		16	4.4	

Features		
Name	Description	Rated value
X1		
BD1 (+)	Connection of a motor holding brake	
BD2 (-)	Output voltage	DC 180 V
	(depending on the mains voltage)	DC 215 V
	Max. output current	0.3 A
	Max. output power	55 VA
	Time-dependent behaviour	See software manual, chapter "Holding brake control/parameter setting"
	Short-circuit-proof	No
	Reset and switch-on behaviour	Outputs are switched off
	Operating frequency	Max. 30/min

## Brake resistor

Terminal data				
Name	Power	Conductor cross-section [mm <sup>2</sup> ] [AWG]	Tightening torque [Nm] [lb-in]	
X1				
Rb1, Rb2	–	1.5	0.5	3.5 x 0.6
		16	4.4	

Features		
Name	Description	Rated value
X1		
Rb1, Rb2	Brake resistor	See rated data

4.6.2 8400 motec 4 ... 7.5 kW

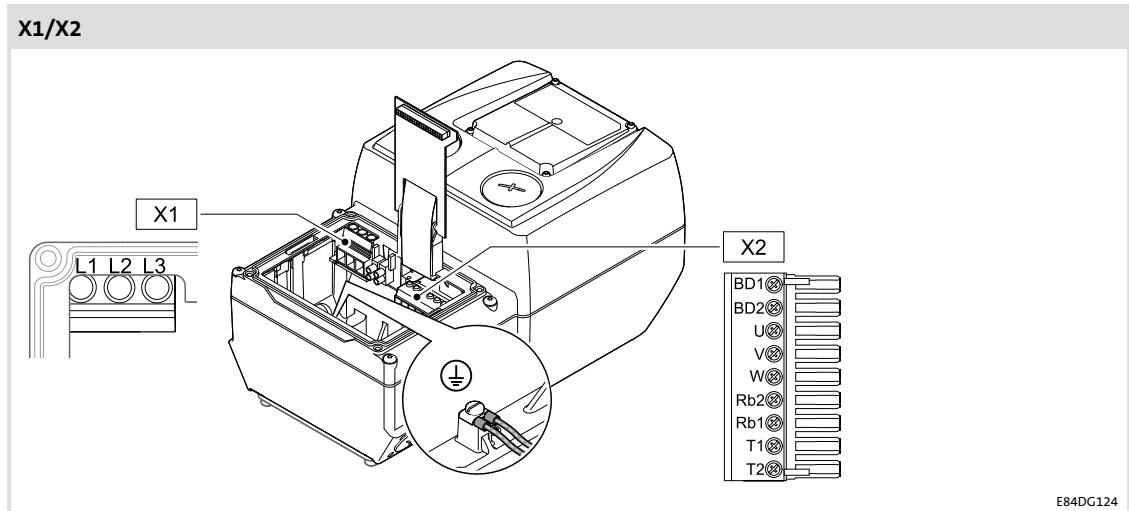

Mains

Terminal data				
Name	Power	Conductor cross-section [mm <sup>2</sup> ] [AWG]	Tightening torque [Nm] [lb-in]	
X1				
L1, L2, L3	4.0 ... 7.5 kW	1 ... 16 18 ... 6	1.4 12	PZ 2 5.5 x 10
		2 x 1 ... 2 x 6 <sup>1)</sup> 18 ... 6		
⊕				
PE	4.0 ... 7.5 kW	1 ... 16 18 ... 6	1.7 15	8 x 1.2

<sup>1)</sup> For looping-through connections (daisy chain) => two conductors with TWIN wire end ferrule



**Note!**

Terminal X1 is not pluggable.

Features		
Name	Description	Rated value
X1		
L1, L2, L3	Mains phases	See rated data

## Motor

Terminal data				
Name	Power	Conductor cross-section [mm <sup>2</sup> ] [AWG]	Tightening torque [Nm] [lb-in]	
X2				
U, V, W	4.0 ... 7.5 kW	1 ... 6 18 ... 8	0.8 7	PH 1 3.5 x 0.6
⊕				
PE	4.0 ... 7.5 kW	1 ... 16 18 ... 6	1.7 15	8 x 1.2

Features		
Name	Description	Rated value
X2		
U, V, W	Motor phases	See rated data

## Motor temperature monitoring

**Danger!****Hazardous electrical voltage**

Terminals T1, T2 are on DC-bus voltage potential.

**Possible consequences:**

- ▶ Death or severe injuries when touching the power terminals.

**Protective measures:**

- ▶ Before working on the terminals, disconnect mains and wait for at least 3 minutes.
- ▶ Check whether the terminals are deenergised.

Terminal data				
Name	Power	Conductor cross-section [mm <sup>2</sup> ] [AWG]	Tightening torque [Nm] [lb-in]	
X2				
T1, T2	0.37 ... 1.5 kW	1.5 16	0.5 4.4	3.5 x 0.6
	2.2 ... 3.0 kW	1 ... 6 18 ... 8	0.8 7.0	

Features		
Name	Description	Rated value
X2		
T1, T2	Motor temperature monitoring	See rated data <b>Danger! Hazardous electrical voltage.</b> ● T1 and T2 have DC-bus voltage potential .

### Motor holding brake

Terminal data				
Name	Power	Conductor cross-section [mm <sup>2</sup> ] [AWG]	Tightening torque [Nm] [lb-in]	
X2				
BD1 (+)	–	1.5	0.5	3.5 x 0.6
BD2 (-)		16	4.4	

Features		
Name	Description	Rated value
X2		
BD1 (+)	Connection of a motor holding brake	
BD2 (-)	Output voltage	DC 180 V
	(depending on the mains voltage)	DC 215 V
	Max. output current	0.3 A
	Max. output power	55 VA
	Time-dependent behaviour	See software manual, chapter "Holding brake control/parameter setting"
	Short-circuit-proof	No
	Reset and switch-on behaviour	Outputs are switched off
	Operating frequency	Max. 30/min

### Brake resistor

Terminal data				
Name	Power	Conductor cross-section [mm <sup>2</sup> ] [AWG]	Tightening torque [Nm] [lb-in]	
X2				
Rb1, Rb2	–	1.5	0.5	3.5 x 0.6
		16	4.4	

Features		
Name	Description	Rated value
X2		
Rb1, Rb2	Brake resistor	See rated data

4.6.3

8400 motec wall mounting

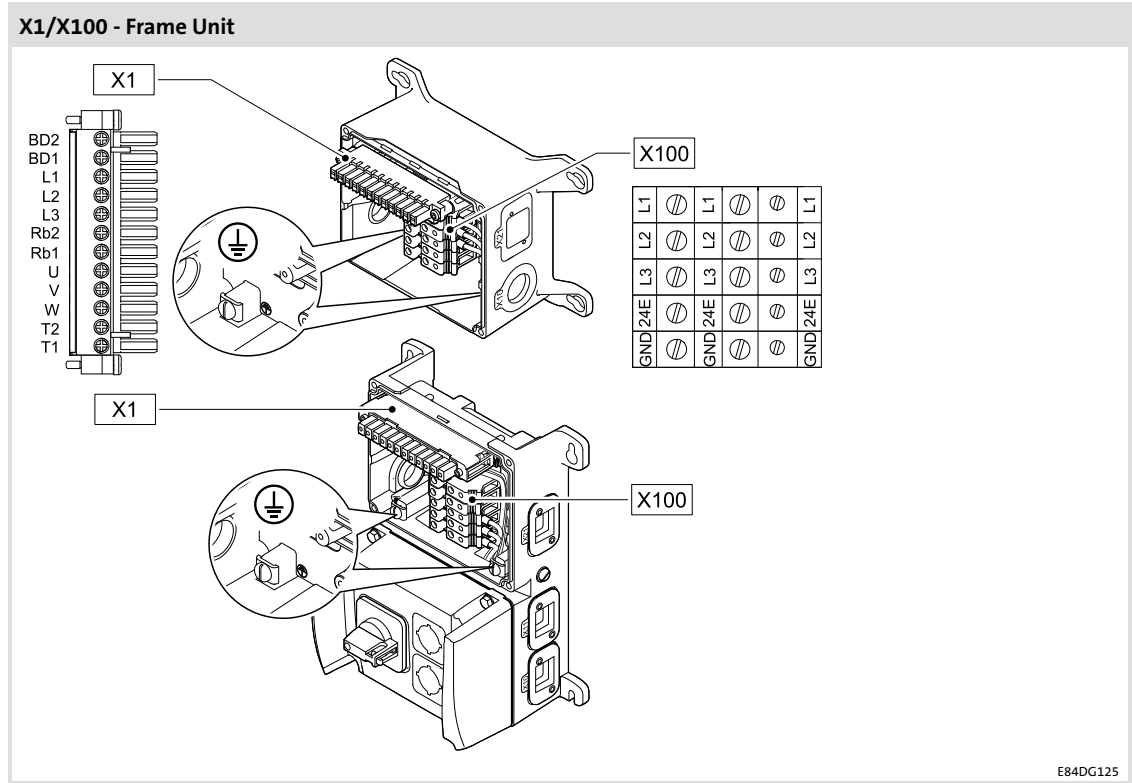

Mains

Terminal data				
Name	Power	Conductor cross-section [mm <sup>2</sup> ] [AWG]	Tightening torque [Nm] [lb-in]	
X100				
L1, L2, L3	0.37 ... 1.5 kW	1 ... 4 18 ... 10	0.5 4.4	3.5 x 0.6
		2 x 0.5 ... 2 x 2.5 <sup>1)</sup> 18 ... 10		
	2.2 ... 3.0 kW	1 ... 6 18 ... 8	0.8 7.0	3.5 x 0.6
		2 x 0.5 ... 2 x 2.5 <sup>1)</sup> 18 ... 8		
⊕				
PE	0.37 ... 1.5 kW	1 ... 4 18 ... 10	1.7 16	8 x 1.2
		2.2 ... 3.0 kW	1 ... 6 18 ... 8	1.7 16

<sup>1)</sup> For looping-through connections (daisy chain) => two conductors with TWIN wire end ferrule

Features		
Name	Description	Rated value
X1		
L1, L2, L3	Mains phases	See rated data

### Motor

Terminal data				
Name	Power	Conductor cross-section [mm <sup>2</sup> ] [AWG]	Tightening torque [Nm] [lb-in]	
X1				
U, V, W	0.37 ... 1.5 kW	1 ... 4 18 ... 10	0.5 4.4	3.5 x 0.6
	2.2 ... 3.0 kW	1 ... 6 18 ... 8	0.8 7.0	
⊕				
PE	0.37 ... 1.5 kW	1 ... 4 18 ... 10	1.7 16	8 x 1.2
	2.2 ... 3.0 kW	1 ... 6 18 ... 8	1.7 16	

Features		
Name	Description	Rated value
X1		
U, V, W	Motor phases	See rated data

### Motor temperature monitoring



#### Danger!

#### Hazardous electrical voltage

Terminals T1, T2 are on DC-bus voltage potential.

#### Possible consequences:

- ▶ Death or severe injuries when touching the power terminals.

#### Protective measures:

- ▶ Before working on the terminals, disconnect mains and wait for at least 3 minutes.
- ▶ Check whether the terminals are deenergised.

Terminal data				
Name	Power	Conductor cross-section [mm <sup>2</sup> ] [AWG]	Tightening torque [Nm] [lb-in]	
X1				
T1, T2	0.37 ... 1.5 kW	1.5 16	0.5 4.4	3.5 x 0.6
	2.2 ... 3.0 kW	1 ... 6 18 ... 8	0.8 7.0	

Features		
Name	Description	Rated value
X1		
T1, T2	Motor temperature monitoring	See rated data <b>Danger! Hazardous electrical voltage.</b> • T1 and T2 have DC-bus voltage potential .

## Motor holding brake

Terminal data				
Name	Power	Conductor cross-section [mm <sup>2</sup> ] [AWG]	Tightening torque [Nm] [lb-in]	
X1				
BD1 (+)	–	1.5	0.5	3.5 x 0.6
BD2 (-)		16	4.4	

Features		
Name	Description	Rated value
X1		
BD1 (+)	Connection of a motor holding brake	
BD2 (-)	Output voltage (depending on the mains voltage)	DC 180 V DC 215 V
	Max. output current	0.3 A
	Max. output power	55 VA
	Time-dependent behaviour	See software manual, chapter "Holding brake control/parameter setting"
	Short-circuit-proof	No
	Reset and switch-on behaviour	Outputs are switched off
	Operating frequency	Max. 30/min

## Brake resistor

Terminal data				
Name	Power	Conductor cross-section [mm <sup>2</sup> ] [AWG]	Tightening torque [Nm] [lb-in]	
X1				
Rb1, Rb2	–	1.5 16	0.5 4.4	3.5 x 0.6

Features		
Name	Description	Rated value
X1		
Rb1, Rb2	Brake resistor	See rated data

## 4.7 Control terminals

### 4.7.1 Overview

	Controller enable	Digital inputs	Digital outputs	Relay outputs	Analog inputs	Safety STO	External 24 V supply
	Number	Number	Number	Number	Number	Number	Number
<b>I/O modules</b>							
Basic I/O	1	2	0	1	0	0	0
Standard I/O	1	5	1	1	1 * U/I	0	0
Standard I/O + M12	1	5	1	1	1 * U/I	0	0
Extended I/O	1	8	1	1	2 * U	0	0
<b>Fieldbus</b>							
AS-Interface / Standard I/O	1	5	1	0	0	0	0
AS-Interface / Enhanced I/O	1	5	1	0	0	0	0
CANopen / Standard I/O	1	5	1	0	0	0	0
CANopen / Enhanced I/O	1	5	1	0	0	0	0
EtherCAT® / Standard I/O	1	5	1	0	0	0	1
EtherCAT® / Enhanced I/O	1	5	1	0	0	0	1
EtherNet/IP / Standard I/O	1	5	1	0	0	0	1
EtherNet/IP / Enhanced I/O	1	5	1	0	0	0	1
POWERLINK / Standard I/O	1	5	1	0	0	0	1
POWERLINK / Enhanced I/O	1	5	1	0	0	0	1
PROFIBUS / Standard I/O	1	5	1	0	0	0	1
PROFIBUS / Enhanced I/O	1	5	1	0	0	0	1
PROFINET / Standard I/O	1	5	1	0	0	0	1
PROFINET / Enhanced I/O	1	5	1	0	0	0	1
<b>Fieldbus with safety</b>							
AS-Interface STO / Standard I/O	1	5	1	1	1 * U/I	1	1
AS-Interface STO / Enhanced I/O	1	5	1	1	1 * U/I	1	1
CANopen STO / Standard I/O	1	5	1	1	1 * U/I	1	1
CANopen STO / Enhanced I/O	1	5	1	1	1 * U/I	1	1
EtherCAT® STO / Standard I/O	1	5	1	1	1 * U/I	1	1
EtherCAT® STO / Enhanced I/O	1	5	1	1	1 * U/I	1	1
EtherNet/IP STO / Standard I/O	1	5	1	1	1 * U/I	1	1
EtherNet/IP STO / Enhanced I/O	1	5	1	1	1 * U/I	1	1
POWERLINK STO / Standard I/O	1	5	1	1	1 * U/I	1	1
POWERLINK STO / Enhanced I/O	1	5	1	1	1 * U/I	1	1
PROFIBUS STO / Standard I/O	1	5	1	1	1 * U/I	1	1
PROFIBUS STO / Enhanced I/O	1	5	1	1	1 * U/I	1	1
PROFINET STO / Standard I/O	1	5	1	1	1 * U/I	1	1
PROFINET STO / Enhanced I/O	1	5	1	1	1 * U/I	1	1

## 4.7.2

## General data

## Standards and application conditions

Feature	Value/designation	
<b>Type of protection</b>		
EN 60529	IP65	
<b>Climatic conditions</b>		
Storage (EN 60721-3-1)	1K3 (temperature: -30 °C ... +60 °C)	
Operation (EN 60721-3-3)	3K3 (temperature: -30 °C ... +55 °C)	
Transport (EN 60721-3-2)	2K3 (temperature: -30 °C ... +75 °C)	
<b>Insulation voltage to PE reference earth</b>		
EN 61800-5-1	U <sub>AC</sub>	50.0 V

## General data

Feature	Value/designation
<b>Analog input, voltage</b>	
Value range	0 ... 10 V
Value range - Extended I/O only	-10 ... +10 V
Resolution	10 bits
Input resistance	>80 kΩ
Sampling frequency	80 Hz (12 ms)
Accuracy	±0.1 V
Electric strength of external voltage	-7 ... +30 V
<b>Analog input, current</b>	
Value range, parameterisable	0.6 ... +20 mA (<0.6 mA corresponds to 0) 4 ... +20 mA, fail-safe
Resolution	10 bits
Input resistance	250 Ω
Input current in the case of an open circuit	Display "0" (I <0.6 mA)
Sampling frequency	80 Hz (12 ms)
Typical accuracy	±0.2 mA
Electric strength of external voltage	-7 ... +7 V
<b>Digital inputs</b>	
Switching level	PLC (IEC 61131-2)
Max. input current	11 mA
<b>Digital outputs</b>	
Switching level	PLC (IEC 61131-2)
Max. output current	50 mA
<b>Relay</b>	
Contact	NO contact
Connection	AC 250 V, 3 A DC 24 V, 2 A ... 240 V, 0.16 A
<b>24 V supply</b>	
External (24E)	DC input voltage: +19.2 ... +28.8 V, max. 120 mA For supporting communication when the mains voltage is disconnected
Internal (24O)	DC output voltage, max. 100 mA for inputs/outputs and sensor supply
<b>Interfaces</b>	

Feature	Value/designation
Extensions	Fieldbus via Communication Unit
Safety system	1 safe input for passive/active actuators
<b>Drive interface</b>	
Encoder input – Basic I/O – Standard I/O – Standard I/O + M12 – Extended I/O – CANopen – PROFIBUS – AS-i	Via 2 digital inputs, HTL, 2-track, 7.5 kHz
Encoder input – PROFINET – POWERLINK – EtherNet/IP – EtherCAT	Via 2 digital inputs, HTL, 2-track, 10 kHz

### Safety system

Feature	Value / description
<b>Communication module</b>	
Standard I/O or Enhanced I/O	AS-Interface STO CANopen STO PROFIBUS STO EtherCAT® STO EtherNet/IP STO POWERLINK STO PROFINET STO
<b>Certification</b>	
EN ISO 13849-1	PLe, category 4
EN 61800-5-2	SIL 3
EN 62061	SIL 3
IEC 61508	SIL 3
<b>Fail-safe state</b>	
	Safe torque off

## 4 Technical data

### Control terminals

#### AS-Interface

#### 4.7.3 AS-Interface

Feature		Value/designation
<b>Standard</b>		EN 50295 / IEC 62026-2
<b>Communication</b>		
Communication profile		AS-Interface V3.0
Medium		Two-core cable for data and auxiliary power
<b>Network topology</b>		Free topology (line, ring, tree, star)
<b>Nodes</b>		Slave (single, dual) Max. 31 standard slaves or safe slaves Max. 62 A/B slaves
<b>Number of nodes</b>		1 ... 31
<b>Max. cable length</b>		
Per bus segment	$I_{\max}$	100 m without repeater/extender 300 m with 2 repeaters/extenders 500 m only in star topologies with 2 repeaters/extenders
<b>Baud rate</b>		167 kbps (gross) 53 kbps (net with data transmission efficiency = 32 %)
<b>Rated voltage</b>	$U_{\text{rated, DC}}$	24.0 V

#### 4.7.4 CANopen®

Feature		Value/designation
<b>Communication</b>		
Communication profile		CANopen, DS301 V4.02 Lenze system bus
Medium		DIN ISO 11898
<b>Baud rate</b>	b	20 kbps 50 kbps 125 kbps 250 kbps 500 kbps 800 kbps 1000 kbps
<b>Network topology</b>		Line with 120 Ohm terminating resistor on both sides
<b>Nodes</b>		Slave Mini master
<b>Number of nodes</b>		63
<b>Number of logic process data channels</b>		2 transmit PDOs and 2 receive PDOs (with 1 ... 8 bytes each)
<b>Number of logic parameter data channels</b>		Max. 2 server SDO channels (with 1 ... 8 bytes)
<b>Max. cable length</b>	$I_{\max}$	17 m with 1000 kbps 40 m with 800 kbps 110 m with 500 kbps 290 m with 250 kbps 630 m with 125 kbps 1500 m with 50 kbps 3900 m with 20 kbps 8000 m with 10 kbps
<b>Rated voltage</b>	$U_{\text{rated, DC}}$	24.0 V

#### 4.7.5 EtherCAT®

Feature	Value/designation	
<b>communication</b>		
Communication profile	CoE (CANopen over EtherCAT)	
Medium	CAT5e S7FTP in compliance with ISO/IEC11801 (2002)	
<b>Baud rate</b>	b	100 kbit/s
<b>Network topology</b>	Line Switch	
<b>Nodes</b>	Slave	
<b>Number of nodes</b>	Max. 65535	
<b>Number of logic process data channels</b>	1	
<b>Process data words (PCD)</b>		
To the master	1 ... 10 (max. 20 bytes, 16 bits/word)	
From the master	1 ... 8 (max. 16 bytes, 16 bits/word)	
<b>Parameter data</b>		
Max. mail box size for CoE transfer	128 bytes	
<b>Max. cable length</b>		
Per bus segment	$I_{max}$	100 m
<b>Rated voltage</b>	$U_{rated}$ , DC	24.0 V

#### 4.7.6 EtherNet/IP™

Feature	Value/designation	
<b>communication</b>		
Communication profile	EtherNET/IP, AC Drive	
Medium	CAT5e S/FTP in compliance with ISO/IEC11801 / EN50173	
<b>Baud rate</b>	b	10/100 Mbit/s (full duplex/half duplex)
<b>Network topology</b>	Tree, star, line	
<b>Nodes</b>	Slave (adapter)	
<b>Number of nodes</b>	Max. 254 in the subnetwork	
<b>Number of logic process data channels</b>	1	
<b>Process data words (PCD)</b>		
16 bit	1 ... 16	
<b>Max. cable length</b>		
Per bus segment	$I_{max}$	100 m
<b>Rated voltage</b>	$U_{rated}$ , DC	24.0 V

## 4.7.7

## PROFIBUS®

Feature	Value/designation	
<b>Communication</b>		
Communication profile	PROFIBUS-DP-V0 (DRIVECOM) PROFIBUS-DP-V1 (PROFIdrive)	
Medium	RS 485	
Baud rate	b	9.6 ... 12000 kbps (automatic detection)
Network topology	With repeater: line or tree Without repeater: line	
Nodes	Slave	
Number of nodes	31 slaves + 1 master per bus segment With repeater: 125	
DP user data length	Optional parameter channel (4 words) + process data words Acyclic parameter data channel (DP-V1): max 240 bytes	
<b>Process data words (PCD)</b>		
16 bit	1 ... 8	
<b>Max. cable length</b>		
Per bus segment	$I_{\max}$	1200 m (depending on the cable type used and the baud rate)
Rated voltage	$U_{\text{rated}}$ , DC	24.0 V

## 4.7.8

## PROFINET®

Feature	Value/designation	
<b>Communication</b>		
Communication profile	PROFINET RT conf. class B	
Medium	CAT5e S/FTP in compliance with ISO/ICE11801 (2002)	
Baud rate	b	100 MBit/s
Network topology	Tree, star, line	
Nodes	Slave (device)	
Number of nodes	31 slaves + 1 master per bus segment With repeater: 125	
DP user data length	to control: 1 ... 10 data words (16 bits/word, max. 20 bytes) from control: 1 ... 8 data words (16 bits/words, max. 16 bytes)	
<b>Process data words (PCD)</b>		
16 bit	1 ... 8	
<b>Max. cable length</b>		
Per bus segment	$I_{\max}$	100 m
Rated voltage	$U_{\text{rated}}$ , DC	24.0 V

#### 4.7.9 POWERLINK

Feature		Value/designation
<b>communication</b>		
Communication profile		Ethernet Powerlink V2
Medium		CAT5e S/FTP in compliance with ISO/ICE11801 (2002)
Baud rate	b	100 MBit/s
Network topology		Tree, star, line
Nodes		Controlled node
Number of nodes		Max. 239 in the subnetwork
Number of logic process data channels		1
<b>Process data words (PCD)</b>		
16 bit		1 ... 6
<b>Max. cable length</b>		
Per bus segment	$I_{\max}$	100 m
Rated voltage	$U_{\text{rated}}$ , DC	24.0 V

## 4 Technical data

### Dimensions

#### Standard motor mounting

### 4.8 Dimensions

#### 4.8.1 Standard motor mounting

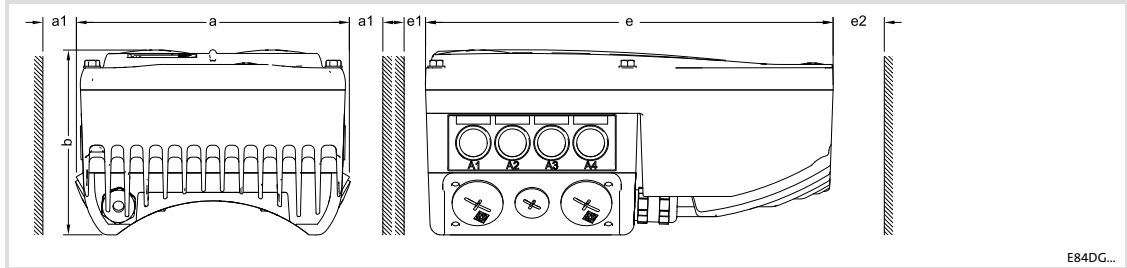

Dimensions - standard motor mounting [mm]

Type	a	b	e	a1	e1	e2	m [kg] <sup>2)</sup>
E84DGDVB371T	161	109	241	75 (20 <sup>1)</sup> )	50	100	2.6
E84DGDVB551T							
E84DGDVB751T							
E84DGDVB112T							
E84DGDVB152T	176	135	261	75 (20 <sup>1)</sup> )	50	100	3.5
E84DGDVB222T							
E84DGDVB302T							
E84DGDVB402T	195	176	325	70 (15 <sup>1)</sup> )	50	100	5.3
E84DGDVB552T							
E84DGDVB752T							

<sup>1)</sup> Reduction possible if no free space for plugs or cable glands is required.

<sup>2)</sup> For the Basic I/O design, without cable glands

4.8.2 Wall mounting without switch

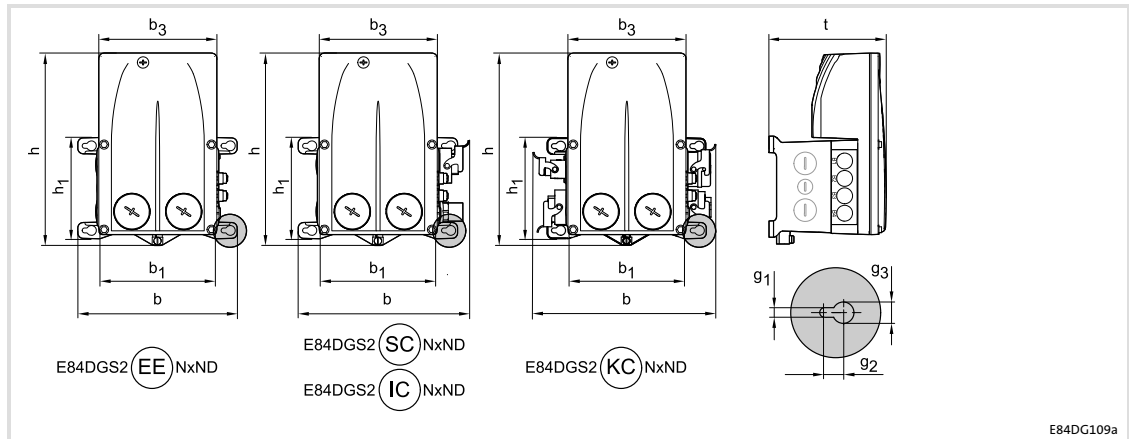

E84DGS2EENxND Design with cable gland  
 E84DGS2SCNxND Design with plug  
 E84DGS2ICNxND Design with plug  
 E84DGS2KCNxND Design with plug

	[kW]	h	b	t	b <sub>1</sub>	b <sub>3</sub>	h <sub>1</sub>	g <sub>1</sub>	g <sub>2</sub>	g <sub>3</sub>	[kg]	IP
		[mm]										
...3714... /	0.37	254	211	156	153	156	143	6.5	9	13	3.5	65
...5514... /	0.55											
...7514... /	0.75											
...1124... /	1.1											
...1524... /	1.5											
...2224... /	2.2											
...3024... /	3.0	274	211	156	153	176	143	6.5	9	13	4.3	

	[kW]	h	b	t	b <sub>1</sub>	b <sub>3</sub>	h <sub>1</sub>	g <sub>1</sub>	g <sub>2</sub>	g <sub>3</sub>	[kg]	IP
		[mm]										
...3714... /	0.37	254	224	156	153	156	143	6.5	9	13	3.8	65
...5514... /	0.55											
...7514... /	0.75											
...1124... /	1.1											
...1524... /	1.5											
...2224... /	2.2											
...3024... /	3.0	274	224	156	153	176	143	6.5	9	13	4.6	
...xxxx... /	≤ 1.5		243								4.1	65
...xxxx... /	≥ 2.2		243								4.9	65

4.8.3

Wall mounting with switch

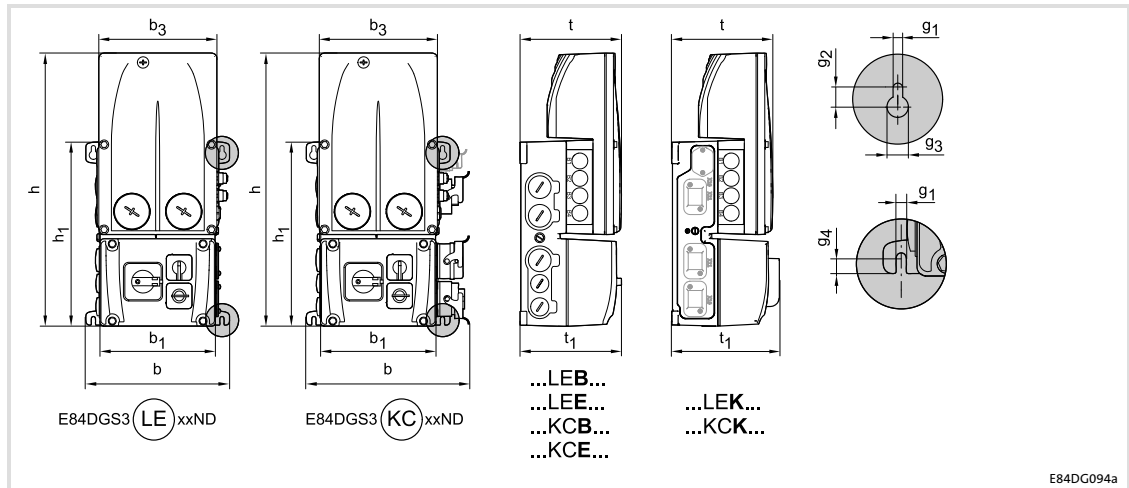

E84DGS3LE<sub>xxND</sub> Design with cable gland  
 E84DGS3KC<sub>xxND</sub> Design with plug

	[kW]	h	b	t	b <sub>1</sub>	b <sub>3</sub>	h <sub>1</sub>	t <sub>1</sub>	g <sub>1</sub>	g <sub>2</sub>	g <sub>3</sub>	g <sub>4</sub>	[kg]	IP
		[mm]												
...3714... /	0.37													54
...5514... /	0.55													
...7514... /	0.75	362	190	134	153	156	245	134	5.5	10	11	8.5	4	
...1124... / ...LEB...	1.1													
...1524... / ...LEE...	1.5													
...2224... /	2.2													
...3024... /	3.0	382	190	134	153	176	245	134	5.5	10	11	8.5	4.8	
...xxxx... / ...LEK...								143						64

	[kW]	h	b	t	b <sub>1</sub>	b <sub>3</sub>	h <sub>1</sub>	t <sub>1</sub>	g <sub>1</sub>	g <sub>2</sub>	g <sub>3</sub>	g <sub>4</sub>	[kg]	IP
		[mm]												
...3714... /	0.37													54
...5514... /	0.55													
...7514... /	0.75	362	215	134	153	156	245	134	5.5	10	11	8.5	4.5	
...1124... / ...KCB...	1.1													
...1524... / ...KCE...	1.5													
...2224... /	2.2													
...3024... /	3.0	382	215	134	153	176	245	134	5.5	10	11	8.5	5.3	
...xxxx... / ...KCK...								143						64

## 5 Installation

### 5.1 Important notes



#### **Danger!**

##### **Dangerous electrical voltage**

All power terminals remain live for up to three minutes after mains disconnection.

##### **Possible consequences:**

- ▶ Death or severe injuries when touching the power terminals.

##### **Protective measures:**

- ▶ Switch off the power supply and wait for at least three minutes before working on the power terminals.
- ▶ Make sure that all power terminals are deenergised.



#### **Danger!**

##### **Hazardous electrical voltage**

The leakage current to earth (PE) is  $> 3.5$  mA AC or  $> 10$  mA DC.

##### **Possible consequences:**

- ▶ Death or severe injuries when touching the device in the event of an error.

##### **Protective measures:**

Implement the measures required in EN 61800-5-1. Especially:

- ▶ Fixed installation
  - Implement PE connection in compliance with standards.
  - Connect PE conductor twice or PE conductor cross-section  $\geq 10$  mm<sup>2</sup>.
- ▶ Connection with a connector for industrial applications according to IEC 60309 (CEE):
  - PE conductor cross-section  $\geq 2.5$  mm<sup>2</sup> as part of a multi-core supply cable.
  - Provide for suitable strain relief.



#### **Danger!**

##### **Hazardous electrical voltage**

Terminals T1, T2 are on DC-bus voltage potential.

##### **Possible consequences:**

- ▶ Death or severe injuries when touching the power terminals.

##### **Protective measures:**

- ▶ Before working on the terminals, disconnect mains and wait for at least 3 minutes.
- ▶ Check whether the terminals are deenergised.



### Stop!

#### No device protection if the mains voltage is too high

The mains input is not internally fused.

#### Possible consequences:

- ▶ Destruction of the device if the mains voltage is too high.

#### Protective measures:

- ▶ Observe the maximally permissible mains voltage.
- ▶ Fuse the device correctly on the supply side against mains fluctuations and voltage peaks.



### Stop!

The device contains components that can be destroyed by electrostatic discharge!

Before working on the device, the personnel must ensure that they are free of electrostatic charge by using appropriate measures.



### Stop!

#### Damage of the device

Mounting or dismounting of the controller, especially the Drive Unit can damage or destroy the device.

#### Possible consequences:

- ▶ The drive may respond in an uncontrolled manner and cause further damages.

#### Protective measures:

- ▶ Only mount or dismount the controller in deenergised status.



### Stop!

#### Pluggable terminal strips or plug connections

Plugging or removing the terminal strips or plug connections during operation may cause high voltages and arcing.

#### Possible consequences:

- ▶ Damage of the devices

#### Protective measures:

- ▶ Switch off device.
- ▶ Only plug or remove the terminal strips or plug connections in deenergised status.



**Stop!**

**Overvoltage at components:**

In case of an earth fault in IT systems, intolerable overvoltages may occur in the plant.

**Possible consequences:**

Destruction of the device.

**Protective measures:**

Before using the controller in the IT system, remove the contact screws on the supply side and the motor side. (📖 5.6).

**Original - English****Warnings!**

- ▶ Use Class 1 wire only.
- ▶ Intended for use with 75 °C wire.
- ▶ Intended for use with copper conductors only.
- ▶ Suitable for use in a surrounding air temperature of 45 °C, and
  - additionally 55 °C when de-rating rules are followed.
- ▶ Hot surface. Risk of burn.
- ▶ Should this device be mounted on a motor, the combination needs to be suitable for the type rating.
- ▶ The supply terminals are to be tightened to:
  - For model suffix's 371, 551, 751, 112, 152 tighten to 4.4 - 5.3 lb-in.
  - For model suffix's 222, and 302, tighten to 7 lb-in.
- ▶ These devices are suitable for use on a circuit capable of delivering not more than 200 000 rms Symmetrical Amperes, 480 V maximum
  - When protected by CC, R, T, or J class fuses or
  - When protected by a circuit breaker having an interrupting rating not less than 200 000 rms symmetrical amperes, 480 V maximum.
- ▶ These devices are suitable for motor group installation on a circuit capable of delivering not more than 200 000 rms Symmetrical Amperes, 480 V maximum
  - When protected by CC, R, T, or J class fuses or
  - When protected by a circuit breaker having an interrupting rating not less than 200 000 rms symmetrical amperes, 480 V maximum.
- ▶ Use fuses and circuit breakers only.

...

**Warnings!**

...

- ▶ Integral solid state short circuit protection does not provide branch circuit protection. Branch circuit protection must be provided in accordance with the National Electrical Code and any additional local codes.
- ▶ The opening of branch circuit protective devices may be an indication that a fault current has been interrupted. To reduce the risk of fire or electric shock, current carrying parts and other components, the controller should be examined and replaced if damaged.
- ▶ These devices provide overload protection rated for 125 % of the rated FLA.

**CAUTION!**

- ▶ Risk of electric shock. Please allow 180 s for the internal capacitors to discharge.

Original - French

**Avertissement !**

- ▶ Utiliser exclusivement des conducteurs Class 1.
- ▶ Utiliser des conducteurs 75 °C.
- ▶ Utiliser exclusivement des conducteurs en cuivre.
- ▶ Convient à une utilisation à une température ambiante maximale de 45 °C ainsi que
  - 55 °C en cas d'application des règles de réduction de puissance.
- ▶ Température élevée en surface. Risque de brûlure.
- ▶ En cas de montage de l'équipement sur le moteur, la combinaison doit être conforme à la qualification du type.
- ▶ Couples de serrage des bornes réseau :
  - Pour les types contenant le suffixe 371, 551, 751, 112, 152 : 0,5 à 0,6 Nm.
  - Pour les types contenant le suffixe 222 et 302 : 0,8 Nm.
- ▶ Convient aux circuits non susceptibles de délivrer plus de 200 000 ampères symétriques eff., maximum 480 V
  - Protection par des fusibles CC de calibre R, T ou J ; ou
  - Protection par disjoncteur à pouvoir de coupure nominal d'au moins 200 000 ampères symétriques eff., maximum 480 V.
- ▶ Convient aux installations de groupe moteur sur des circuits non susceptibles de délivrer plus de 200 000 ampères symétriques eff., maximum 480 V
  - Protection par des fusibles CC de calibre R, T ou J ; ou
  - Protection par disjoncteur à pouvoir de coupure nominal d'au moins 200 000 ampères symétriques eff., maximum 480 V.
- ▶ Utiliser exclusivement des fusibles et des disjoncteurs.

...

**Avertissement !**

...

- ▶ La protection statique intégrée n'offre pas la même protection qu'un disjoncteur. Une protection par disjoncteur externe doit être fournie, conformément au National Electrical Code et aux autres dispositions applicables au niveau local.
- ▶ Le déclenchement des dispositifs de protection du circuit de dérivation peut être dû à une coupure qui résulte d'un courant de défaut. Pour limiter le risque d'incendie ou de choc électrique, examiner les pièces porteuses de courant et les autres éléments du contrôleur ; les remplacer s'ils sont endommagés.
- ▶ Ces équipements intègrent une protection contre les surcharges conçue pour se déclencher à 125 % de l'intensité assignée à pleine charge.

**ATTENTION !**

- ▶ Risque de choc électrique. Patientez 180 s pour permettre aux condensateurs internes de se décharger.

**5.3 Installation according to EMC (installation of a CE-typical drive system)****Design of the cables**

- ▶ The cross-section of the PE conductor must be dimensioned according to the relevant national regulations.
- ▶ The cables used must comply with the approvals required for the location (e.g. UL).

**5.3.1 Shielding****Requirements**

- ▶ The effectiveness of a shielded cable is reached by:
  - Providing a good shield connection through large-surface shield contact.
  - Using only braided shields with low shield resistance made of tin-plated or nickel-plated copper braid.
  - Using braided shields with an overlap rate > 70 % and an overlap angle of 90 °.
  - Keeping unshielded cable ends as short as possible.

Use system cables or shielded cables for these connections:

- ▶ Motor
- ▶ External brake resistor (⚠ Mounting Instructions of the brake resistor)
- ▶ Motor holding brake (shielding is required when being integrated into the motor cable; connection to optional motor brake control)
- ▶ Motor temperature monitoring
- ▶ Analog signals (inputs and outputs; single-sided shield connection to the controller)
- ▶ Fieldbus communication (e.g. CANopen, PROFIBUS, ...)
- ▶ Safety system

The following connections need not be shielded:

- ▶ Mains
- ▶ 24-V supply
- ▶ Digital signals (inputs and outputs).
  - We recommend to use shielded cables for a cable length from approximately 5 m on or in environments with strong interferences.

**Connection system**

- ▶ Extensively apply shielding directly in the plugs.
- ▶ Apply shielding above EMC cable glands.

### 5.3.2 Motor cable

- ▶ Only use shielded motor cables with braids made of tinned or nickel-plated copper. Shields made of steel braids are not suitable.
  - The overlap rate of the braid must be at least 70 % with an overlap angle of 90 °.
- ▶ The cables used must correspond to the requirements at the location (e.g. EN 60204-1).
- ▶ Use Lenze system cables.
- ▶ Extensively apply the shielding in the plug and attach it in a way which ensures electrical conductivity.
- ▶ The motor cable is optimally installed if
  - it is separated from mains cables and control cables,
  - it only crosses mains cables and control cables at right angles,
  - it is not interrupted.
- ▶ If the motor cable must be opened all the same (e.g. due to chokes, contactors, or terminals):
  - The unshielded cable ends may not be longer than 100 mm (depending on the cable cross-section).
  - Install chokes, contactors, terminals etc. spatially separated from other components (with a min. distance of 100 mm).
  - Install the shield of the motor cable directly before and behind the point of separation to the mounting plate with a large surface.
- ▶ Connect the shield with a large surface to PE in the terminal box of the motor at the motor housing.
  - Metal EMC cable glands at the motor terminal box ensure a large surface connection of the shield with the motor housing.

#### Wiring on the motor side



#### Stop!

The motor cable is highly susceptible to interference. Therefore you will achieve an optimum wiring on the motor side if you

- ▶ exclusively use shielded and low-capacitance motor cables.
- ▶ do **not** integrate any further cable into the motor cable (e.g. for blowers etc.).
- ▶ shield the supply cable for temperature monitoring of the motor (PTC or thermostat) and install it separately from the motor cable.

Special conditions allow you to integrate the supply cable for temperature monitoring of the motor into the motor cable: (📖 81)

**Danger!****Uncontrolled motor movements can occur**

If the motor cable is damaged, a short circuit between the brake control cables and the motor cables can cause motor movements with low torque.

**Possible consequences:**

- ▶ Personnel in the vicinity of the motor can be injured.

**Protective measures:**

- ▶ Install motor cable in a protected way (e.g. in a cable duct).

**5.3.3 Control cables**

- ▶ Control cables must be shielded to minimise interference injections.
- ▶ Connect the shield correctly:
  - Connect the shield of digital input and output cables at both ends.
  - Connect the shield of analog input and output cables at one end (at the drive controller).
- ▶ To achieve an optimum shielding effect (in case of very long cables, with high interference) one shield end of analog input and output cables can be connected to PE potential via a capacitor (e.g. 10 nF/250 V) (see sketch).

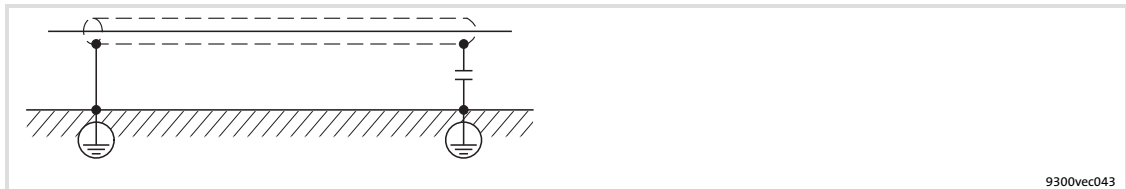

Fig. 5-1 Shielding of long, analog control cables

9300vec043

**5.3.4 Detecting and eliminating EMC interferences**

Fault	Cause	Remedy
Interferences of analog setpoints of your own or other devices and measuring systems	Unshielded motor cable	Use shielded motor cable
	Shield contact is not extensive enough	Carry out optimal shielding as specified
	Shield of the motor cable is interrupted by terminal strips, switched, etc.	<ul style="list-style-type: none"> <li>● Separate components from other component part with a minimum distance of 100 mm</li> <li>● Use motor choke/motor filter</li> </ul>
	Install additional unshielded cables inside the motor cable (e.g. for motor temperature monitoring)	Install and shield additional cables separately
	Too long and unshielded cable ends of the motor cable	Shorten unshielded cable ends to maximally 40 mm

## 5.4 Installation of 8400 motec pre-assembled on the motor

The worksteps to be done during the installation of pre-assembled 8400 motec controllers depend on the selected connection type of the Wiring Unit:

- ▶ Plugs
- ▶ Cable gland (M25)

### 5.4.1 Installation instructions

- ▶ If the cooling air is polluted (fluff, (conductive) dust, soot, aggressive gases), take adequate countermeasures, as e.g.:
  - Regular cleaning of the cooling ribs at the controller
  - Separate air guide
- ▶ Possible mounting position:
  - Observe information on mounting conditions in the chapter "Technical data".
- ▶ Maintain the specified free spaces above and below the controller to other installations!
- ▶ Ensure untroubled cooling and exhaust air flow.
  - Arrangement of several devices only to the sides

### 5.4.2 Plug at the Wiring Unit

The motor has already been wired with the Wiring Unit by the manufacturer. Make sure that the plug assignment of the mains cable complies with the plug at the Wiring Unit. You must plug on and lock the mains cable with the suitable plug.

**5.4.3 Attaching the cable gland****0.37 ... 3 kW**

In order to be able to screw the cable glands in the Wiring Unit and connect the mains cable, you must first dismount the Drive Unit and the Communication Unit as follows:

1. Loosen the four (captive) fixing screws of the motor inverter.
2. Remove the Drive Unit from the Communication Unit without twisting it.
3. Remove the already wired Communication Unit from plug-in connections or provide for sufficient free moving space of an available cable harness.
4. Unlock the Communication Unit (see fig. below). Remove the Communication Unit and position it such that the Wiring Unit can be freely accessed for wiring.
5. Unscrew screw-type blank cap and replace by cable gland. Restore the sealing requirements.
6. Insert mains cable and wire with L1 ... L3 and the earth connection  $\oplus$ .
  - The same procedure applies to a subsequent connection of another mains cable for loop-through or a cable for an external brake resistor.
  - For an installation of the controller conforming to standards, the second earth connection  $\oplus$  can be used for an additional equipotential bonding.
7. Mount the Communication Unit and the Drive Unit in reversed order of the described steps.

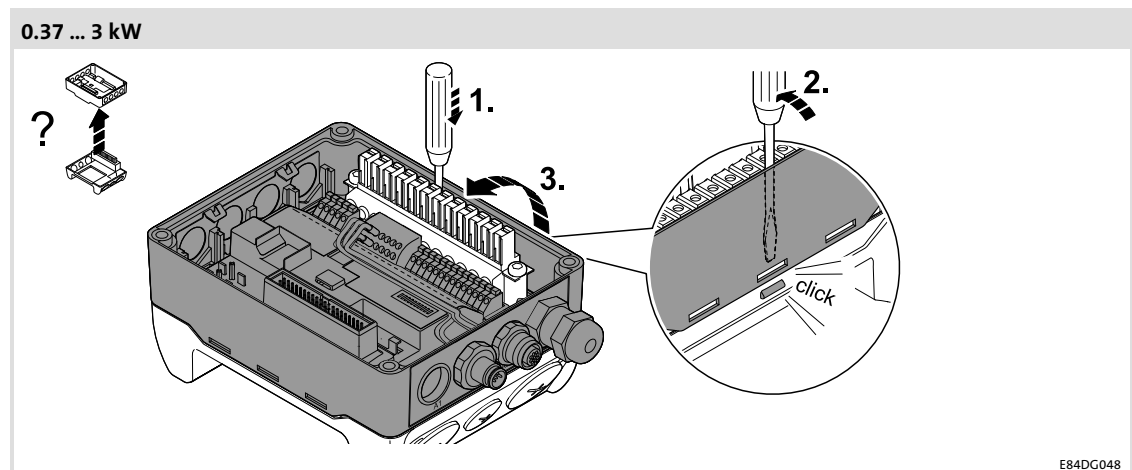

**4 ... 7.5 kW**

In order to be able to screw the cable glands into the Drive Unit and connect the mains cable, you must first dismount the Communication Unit as follows:

1. Remove the already wired Communication Unit from plug-in connections or provide for sufficient free moving space of an available cable harness.
2. Loosen the four (captive) screws of the cover of the Communication Unit completely and remove the cover.
3. Pull the hinged socket connector carefully from the counter plug and turn it into an upright position. Remove the Communication Unit abziehen and position it in such a way that the Drive Unit is sufficiently freely accessible for wiring.
4. Unscrew screw-type blank cap and replace by cable gland. Restore the sealing requirements.
5. Insert mains cable and wire with L1 ... L3 and the earth connection  $\oplus$ .  
– The same procedure applies to a subsequent connection of another mains cable for loop-through or a cable for an external brake resistor.
6. Re-assemble the frequency inverter in reversed order of the described steps.

**5.5 Retrofitting the 8400 motec controller**

8400 motec motor inverters for retrofitting existing drives and motors are supplied as set so that they can be mounted directly without previous dismounting. A set consists of components which are packaged and marked separately:

- ▶ Wiring Unit, marked with ① - WU
- ▶ Communication Unit, marked with ② - CU
- ▶ Drive Unit, marked with ③ - DU
- ▶ Accessories (optional), marked with ④ - opt x

Before working on an existing drive, make sure that the system is isolated from supply and protected against restart.

**5.5.1 Installation instructions**

- ▶ If the cooling air is polluted (fluff, (conductive) dust, soot, aggressive gases), take adequate countermeasures, as e.g.:
  - Regular cleaning of the cooling ribs at the controller
  - Separate air guide
- ▶ Possible mounting position:
  - Observe information on mounting conditions in the chapter "Technical data".
- ▶ Maintain the specified free spaces above and below the controller to other installations!
- ▶ Ensure untroubled cooling and exhaust air flow.
  - Arrangement of several devices only to the sides

For mounting, use the screws of the motor terminal box. The installation material must ensure a durable mechanical connection.

If screws must be replaced, we recommend the following, depending on the motor frame size:

- ▶ M4/M5/M6 cheese head screw, hexagon socket, according to DIN 912/ISO 4762
- ▶ M4/M5/M6 cheese head screw, torx, according to ISO 14579

**5.5.2 Preparing a motor for the 8400 motec installation**

In order to install the 8400 motec, you must first remove the terminal box housing. In case of a standard motor, proceed as follows:

1. After loosening the screws, remove the terminal box cover.
2. Loosening the screws of the terminal box housing. Keep the screws for later fastening of the WU.
3. Remove the terminal box housing and make sure that the seal for the terminal box flange is kept for further use with the WU.
4. Usually, no measures have to be taken at the motor terminal block to mount the WU.

### 5.5.3 Mounting the Wiring Unit

#### 0.37 ... 3 kW

Before being mounted, the WU can be extended with accessories. If there is sufficient space, accessories can also be mounted subsequently if required. The plug connector in the WU should be removed for easier handling and later wiring.

Proceed as follows:

1. Remove the plug connector.
2. Remove the blanking plugs from the WU that are to be replaced by cable glands or accessories for plug connection.
3. Mount the cable glands or the accessories for plug connection considering the sealing requirements.
4. Mount the WU onto the terminal box flange with the existing seal and screws. Earthing is achieved by forced contacting.
5. Install the mains connection cable and, if required, additional cables for the external brake resistor and/or motor holding brake.
6. Wire the mains connection, the brake resistor and/or motor holding brake (if required) to the plug connector. The PE conductor of the mains cable must be connected to one of the earthing connectors  $\oplus$  in the WU.
  - In order to ensure compliance with the standards when installing the inverter, the second earth connection  $\oplus$  can be used for an additional equipotential bonding.
7. Bolt down the plug connector of the WU in the defined position.

The mounting of the WU is now completed mechanically and electrically.

**4 ... 7.5 kW**

The Wiring Unit is mounted to the Drive Unit by means of the four supplied screws and the seal. In the case of this device size, accessories are mounted to the Drive Unit. If there is sufficient space, it is also possible to mount accessories subsequently. The plug connectors of the Wiring Unit are enclosed loosely.

Proceed as follows:

1. Mount the Wiring Unit to the Drive Unit.
2. Mount the Wiring Unit (with mounted Drive Unit) to the terminal box flange with the supplied seal and the original screws. Earthing is achieved by means of forced contact.
3. Install the mains connection cable and, if required, additional cables for the external brake resistor and/or motor holding brake.
4. Wire the mains connection, the brake resistor and/or motor holding brake (if required) to the plug connector. The PE conductor of the mains cable must be connected to one of the earthing connectors (⊕) in the Drive Unit.
  - For an installation of the controller conforming to standards, the second earth connection (⊕) can be used for an additional equipotential bonding.
5. Plug the plug connectors of the Wiring Unit onto the Drive Unit.

The mounting of the Wiring Unit and the Drive Unit is now completed mechanically and electrically.

**5.5.4 Mounting of the Communication Unit****0.37 ... 3 kW**

The CU can be extended with accessories before being mounted. Additional cable glands or M12 connectors for further input and output signals can be mounted.

How to proceed:

1. In order to protect the CU electronics from damage, it must be unhooked and separated from the CU frame.
2. Open the prepared bushings as required. Use a suitable tool, e.g. a big screwdriver or step drill, to remove the areas from inside out. If required, plane rough edges.
3. Insert a connector M12 or cable gland with seal and screw down.
4. Position the CU frame onto the WU. The CU can be rotated by 180° in order that the position of the cable outlets meets the requirements of the local conditions.
5. Insert the CU electronics and let it snap into place.
6. Wire the additional signals.
7. If a fieldbus is used, where address and transmission speed can be set, they must be set right now since later settings are only possible after dismantling the DU.

The mounting of the CU is now completed mechanically and electrically.

#### 4 ... 7.5 kW

The CU can be extended with accessories before being mounted. Additional cable glands or M12 connectors for further input and output signals can be mounted.

How to proceed:

1. Turn the hinged socket connector into an upright position.
2. In order to protect the CU electronics from damage, it must be unhooked and separated from the CU frame.
3. Open the prepared bushings as required. Use a suitable tool, e.g. a big screwdriver or step drill, to remove the areas from inside out. If required, plane rough edges.
4. Insert a connector M12 or cable gland with seal and screw down.
5. Position the CU frame onto the DU aufsetzen. The CU can be rotated by 180° in order that the position of the cable outlets meets the local requirements in an optimal way.
6. Insert the CU electronics and let it snap into place.
7. Wire the additional signals.
8. Turn the hinged socket connector towards the CU and carefully insert it into the counter plug.
9. If a fieldbus is used, where address and transmission speed can be set, they must be set right now since later settings are only possible after dismantling the cover.
10. Mount the cover of the Drive Unit to the CU with four screws (1.5 Nm/13 lb-in).

The mounting of the CU is now completed mechanically and electrically.

#### 5.5.5 Settings at the Drive Unit

Besides parameter setting of the DU via diagnosis terminal (keypad with cable connection) or parameter setting using the »Engineer«, some features can be set directly (📖 150).

#### 5.5.6 Mounting of the Drive Unit

##### 0.37 ... 3 kW

If all previous steps have been executed and completed, the DU can be mounted.

How to proceed:

1. Position the DU in parallel to the WU and CU without twisting it. The four fixing screws show the correct position if they are put through the locating holes of the CU into the threads of the WU.
2. The connectors are contacted with light pressure and the DU has reached the final position.
3. Tighten the four fixing screws (5.0 Nm/44 lb-in)

The installation is completed.

**4 ... 7.5 kW**

The DU has already been mounted with the WU and is completed by attaching the cover to the CU.

## 5.6 Measures when drive is used in IT systems

If the drive is mounted within an IT system, internal filters must be separated from the PE conductor.

How to proceed:

1. If the controller has already been mounted: switch off mains voltage!
2. Make IT screw accessible.
  - Devices up to 3 kW: unscrew small cap on the top.
  - Devices from 4 kW: remove small cover on the top.
3. Unscrew and remove the screw(s).
4. Screw the cap on or fit the cover.

### IT system

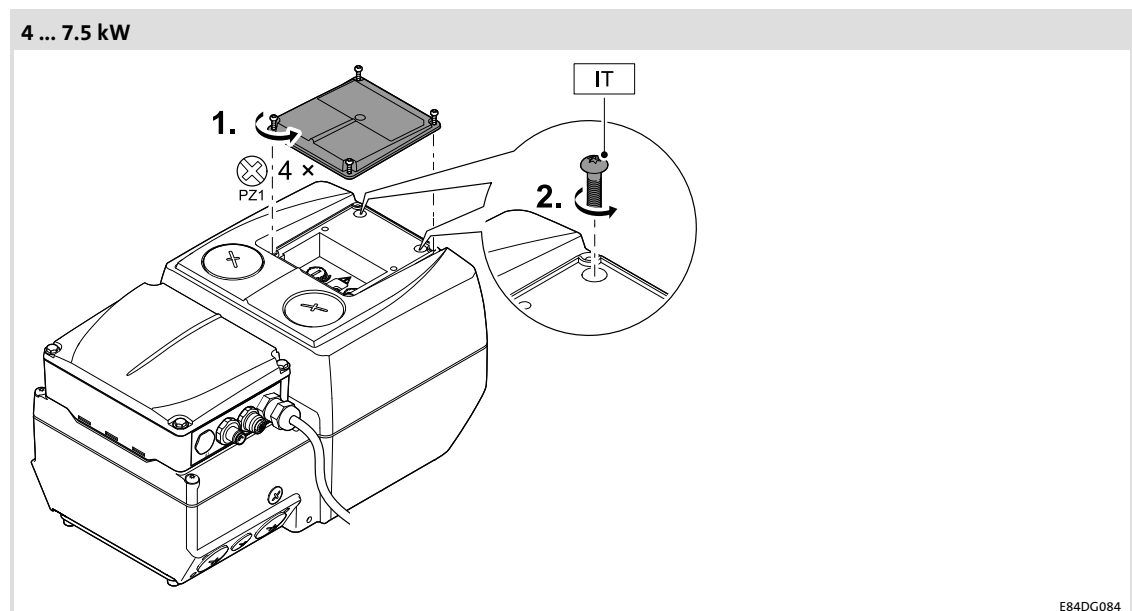
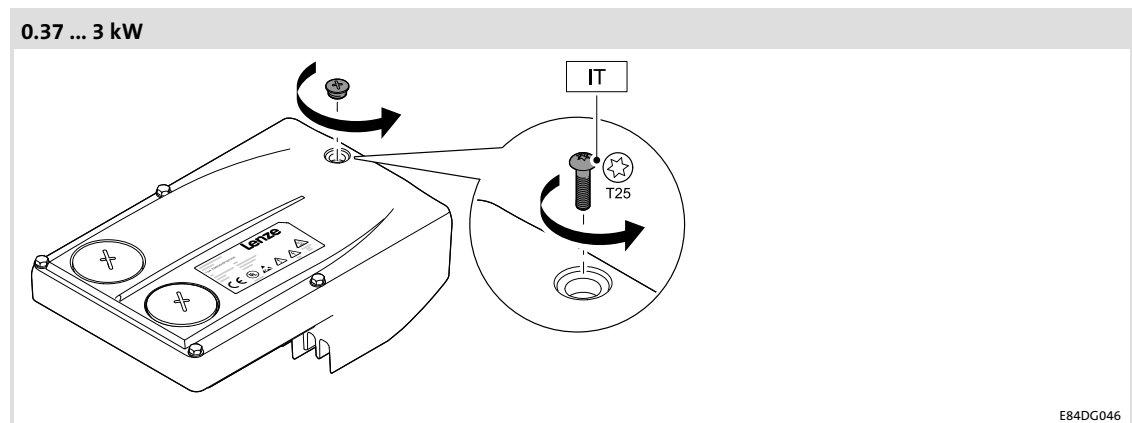

**5.7 Wall mounting****5.7.1 Installation instructions**

- ▶ If the cooling air is polluted (fluff, (conductive) dust, soot, aggressive gases), take adequate countermeasures, as e.g.:
  - Regular cleaning of the cooling ribs at the controller
  - Separate air guide
- ▶ Possible mounting position:
  - Observe information on mounting conditions in the chapter "Technical data".
- ▶ Maintain the specified free spaces above and below the controller to other installations!
- ▶ Ensure untroubled cooling and exhaust air flow.
  - Arrangement of several devices only to the sides

5.7.2 Wall adapter for 4 ... 7.5 kW

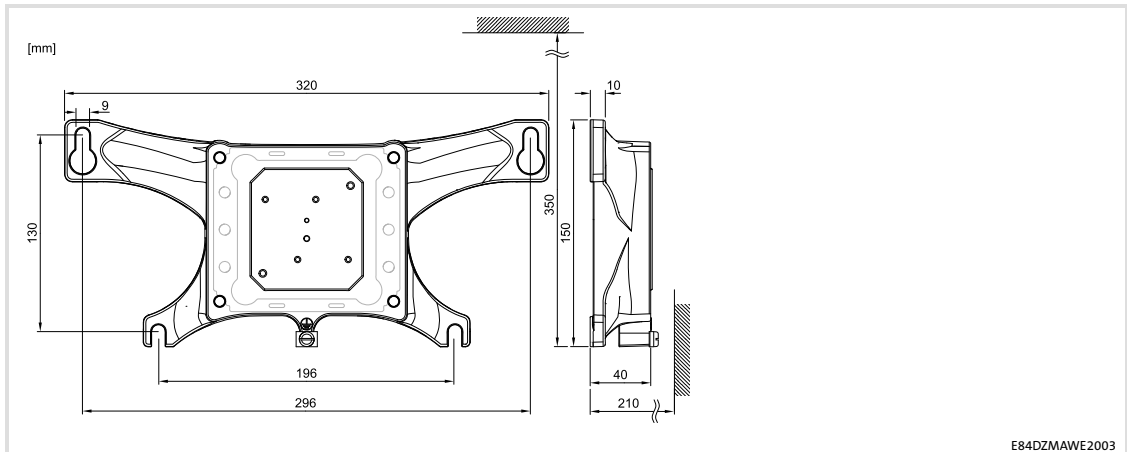



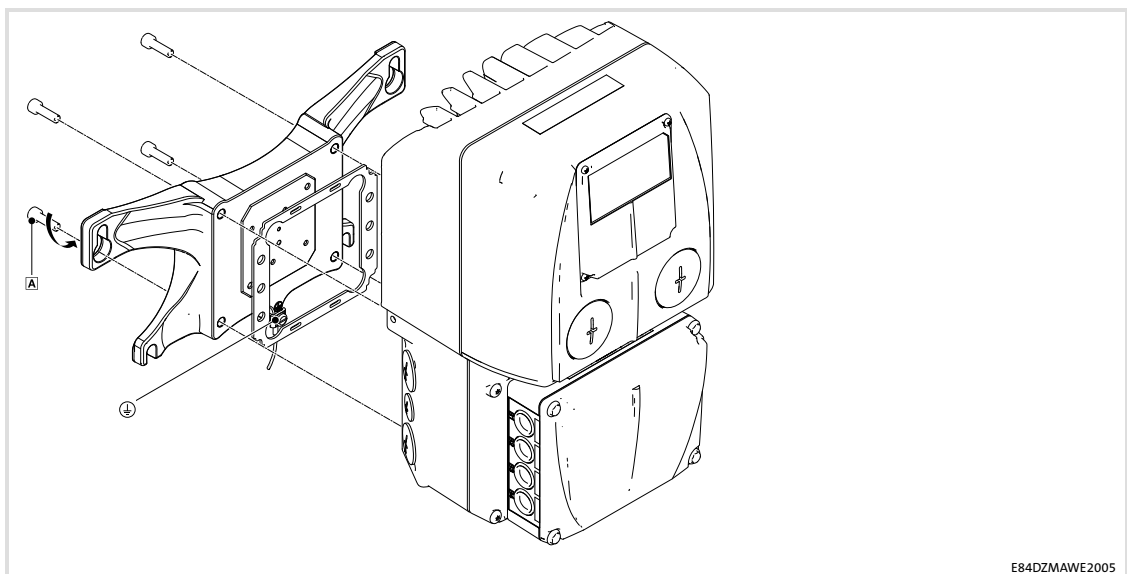



E84DZMAWE2003



E84DZMAWE2005

 A	 Nm / [lb-in]
M6	5 / 44

 PE	 [mm <sup>2</sup> ] [AWG]	 [mm]	 [Nm] [lb-in]	
	1 ... 6 18 ... 10	12	2.7 24	8.0 x 1.2
	1 ... 16 18 ... 6	10		

## 5

### Installation

#### Wall mounting

#### Wall mounting without switch

##### 5.7.3

#### Wall mounting without switch

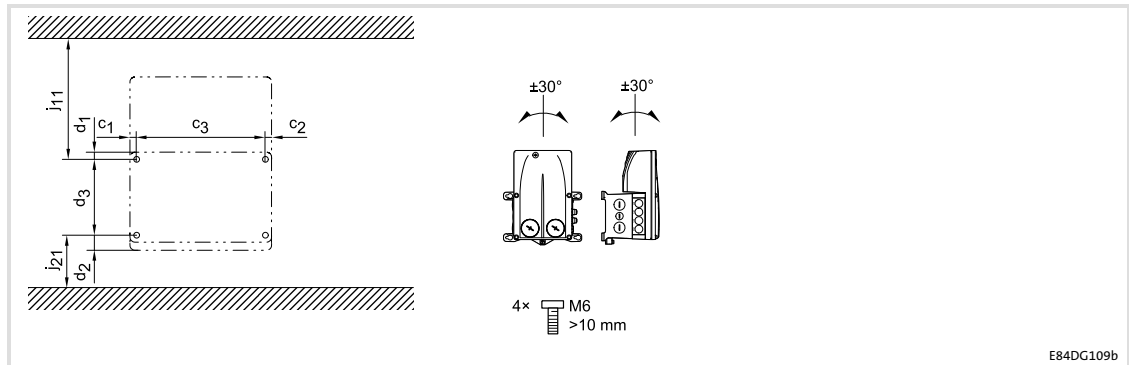

E84DG109b

		c1	c2	c3	d1	d2	d3	j11	j21
[kW]		[mm]							
...3714...	0.37	9	18	184	11	19.9	112.1	177	70
...5514...	0.55								
...7514...	0.75								
...1124...	1.1								
...1524...	1.5								
...2224...	2.2	9	18	184	11	19.9	112.1	194	70
...3024...	3.0								

##### 5.7.4

#### Wall mounting with switch

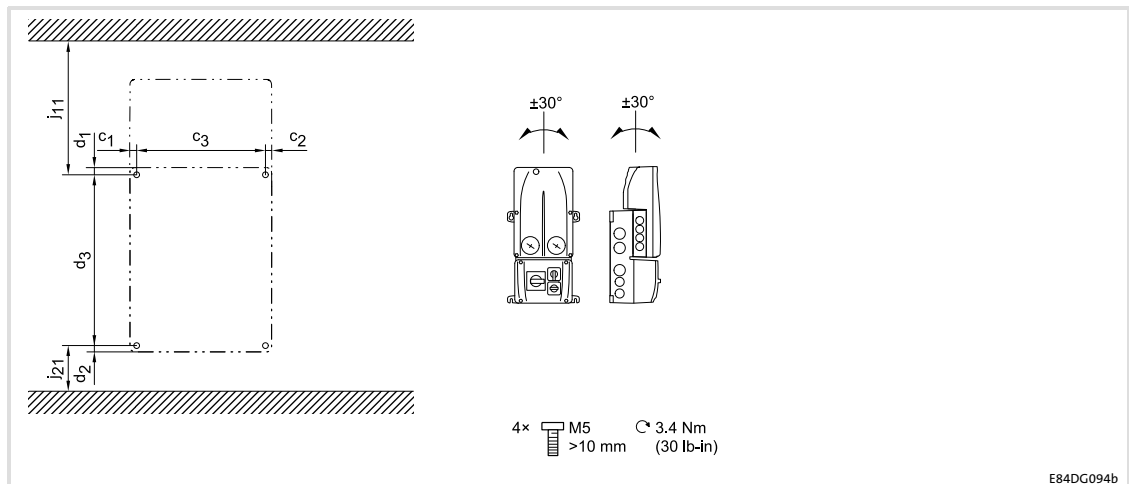

E84DG094b

		c1	c2	c3	d1	d2	d3	j11	j21
[kW]		[mm]							
...3714...	0.37	10.0	10.0	170	10.0	10.5	226	176	60.0
...5514...	0.55								
...7514...	0.75								
...1124...	1.1								
...1524...	1.5								
...2224...	2.2	10.0	10.0	170	10.5	10.5	226	193	60.0
...3024...	3.0								

**5.8 Power terminals**

**5.8.1 Standard motor mounting**

**Motor mounting 0.37 ... 3 kW**

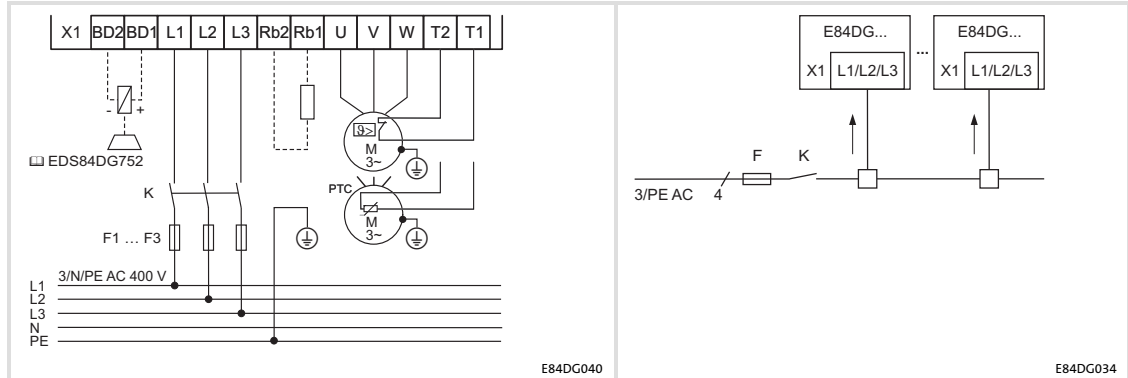

**Motor mounting 4 ... 7.5 kW**

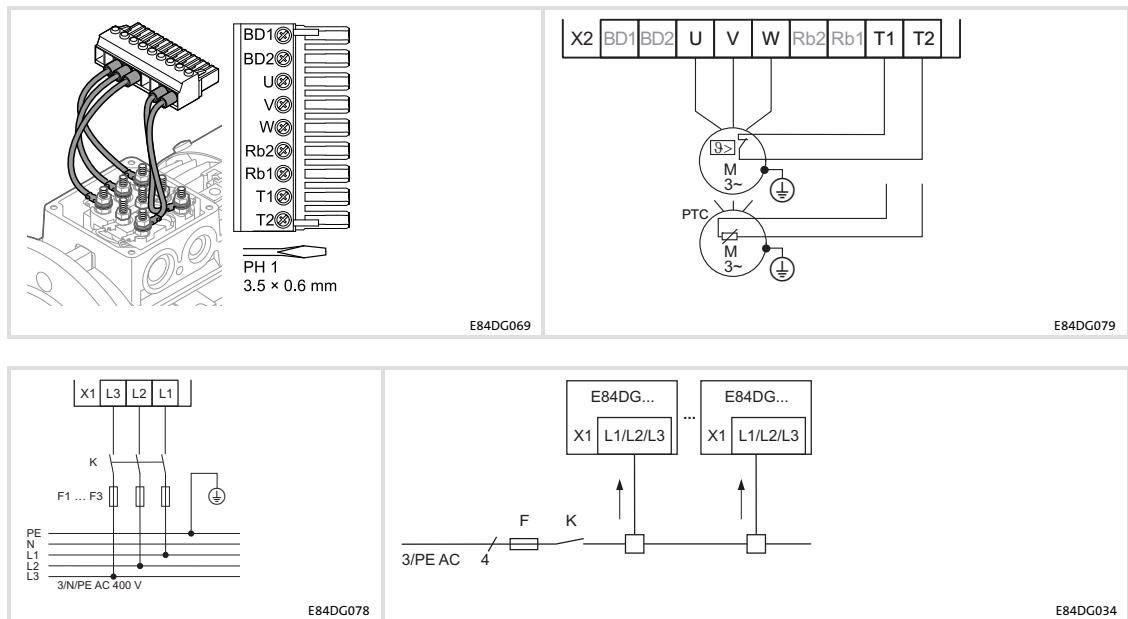

# 5

## Installation

Power terminals  
Product extensions

### 5.8.2 Product extensions

For motor mounting, the 8400 motec can be electrically installed by means of plug-in modules.

The plug-in modules are optionally available as separate accessories.

The plug-in modules are not suitable for operation with increased rated power of 9.2 kW.

#### E84DZEVbXPNP

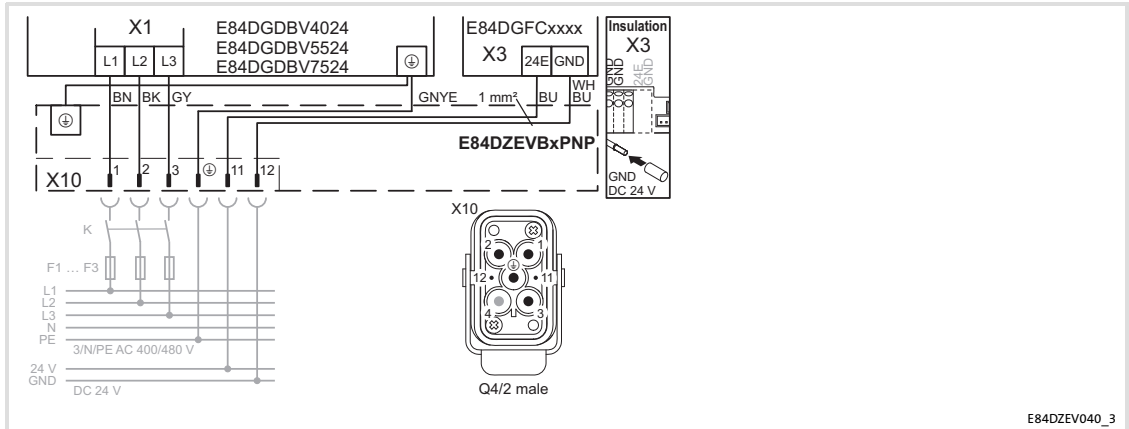

E84DZEV040\_3

#### E84DZEVbXPRP

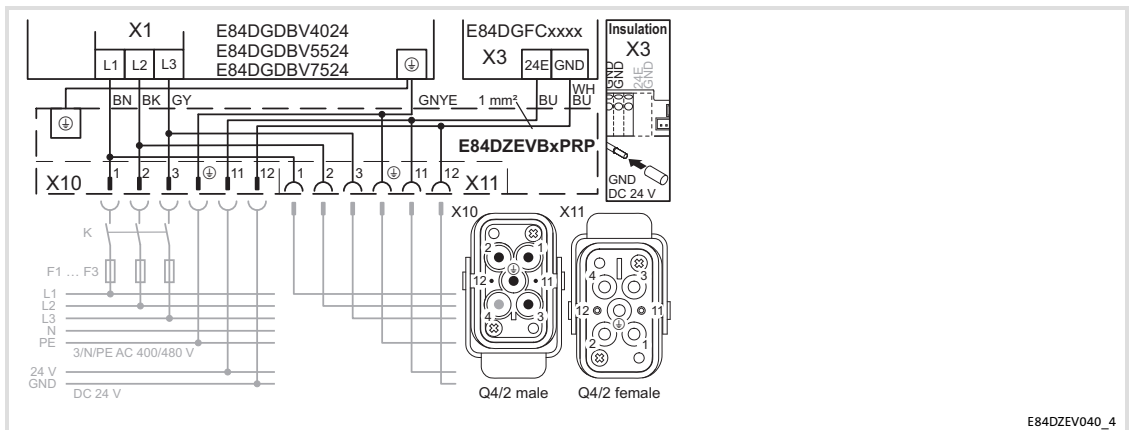

E84DZEV040\_4

5.8.3 Wall mounting without switch

Wandmontage 0.37 ... 3 kW

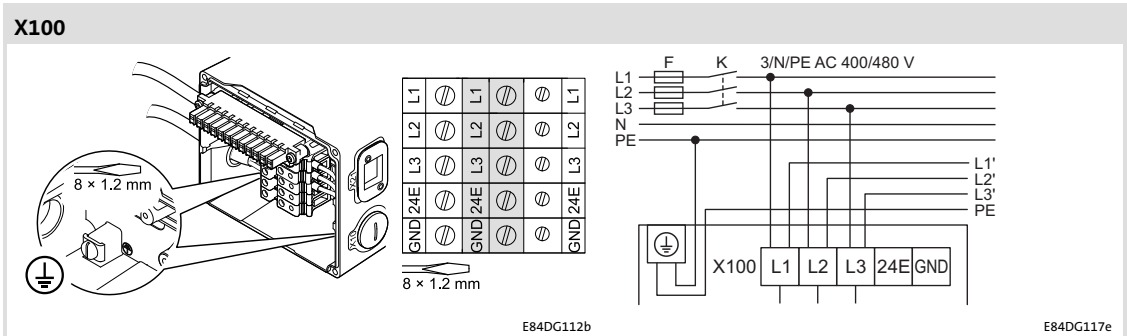
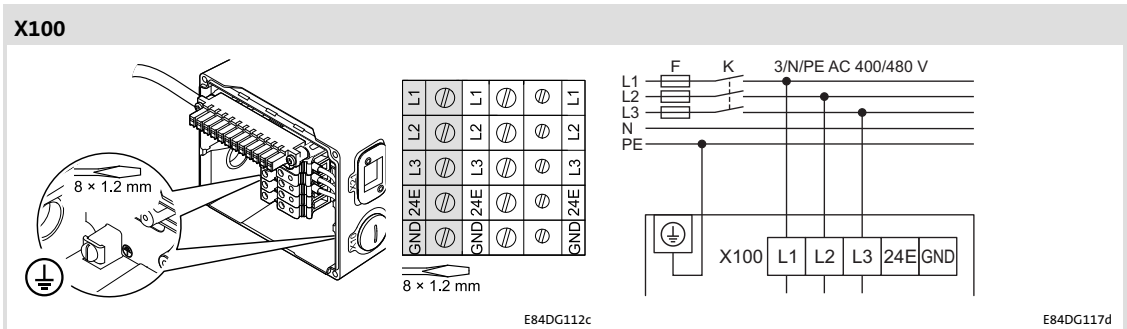
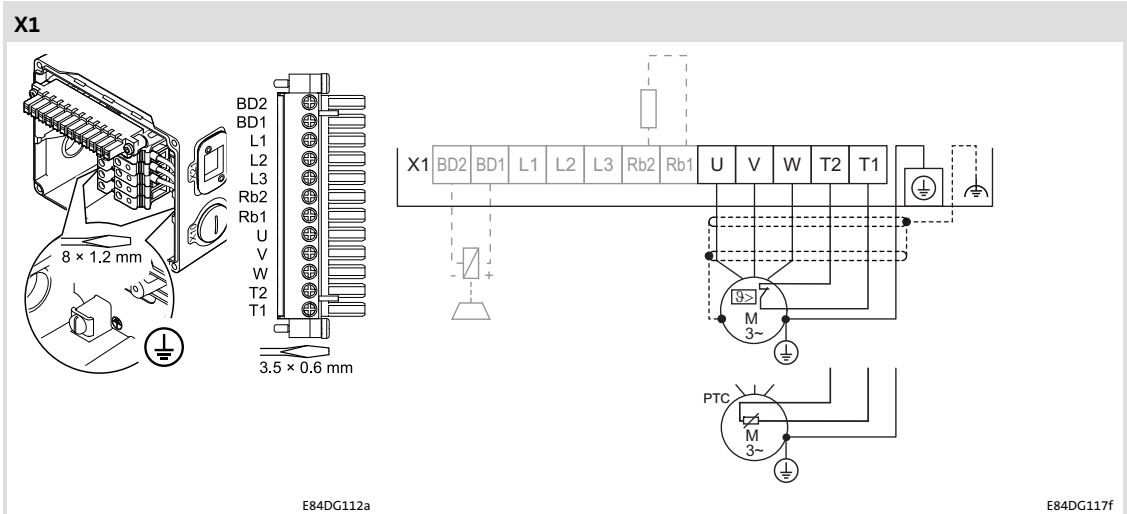

# Installation

Power terminals  
Wall mounting without switch

For wall mounting, the 8400 motec can be configured such that they can be electrically installed by plug-in connection.

## E84DGS2 SC NxNP

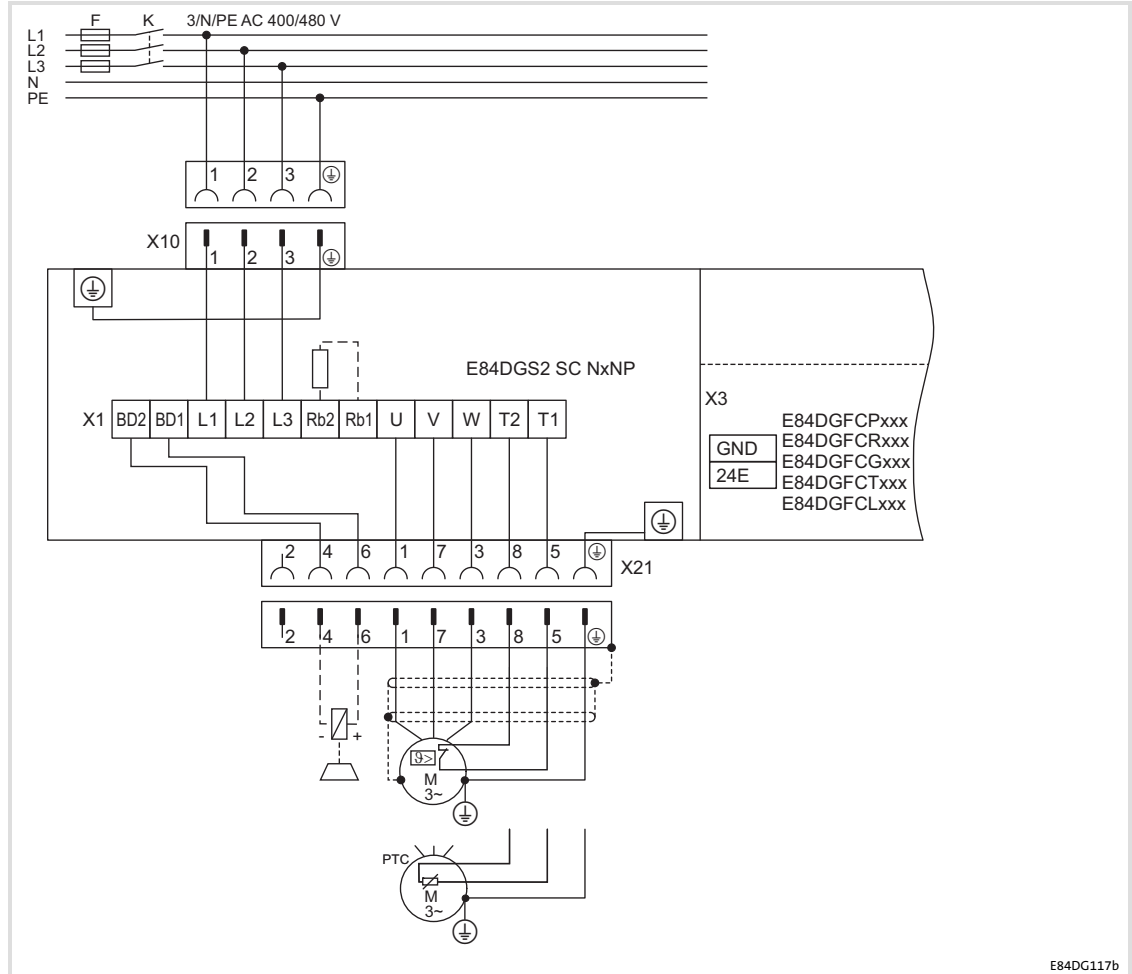

E84DG117b

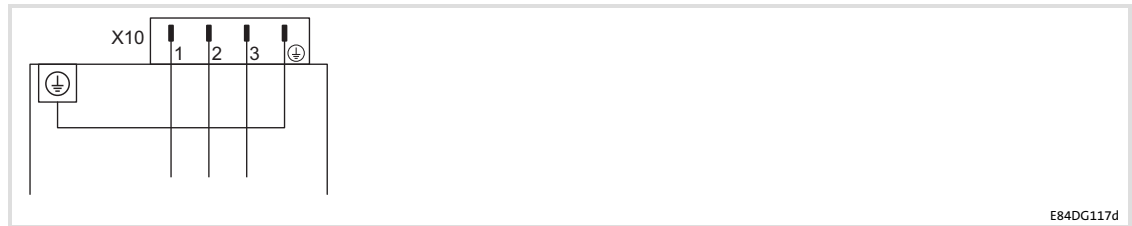

E84DG117d

X10		U <sub>max</sub>	I <sub>max</sub>
<p>E84DG118</p>	1	L1	480 V AC 20 A (UL: 15 A)
	2	L2	
	3	L3	
	⊕	PE	

**E84DGS2 IC NxNP**

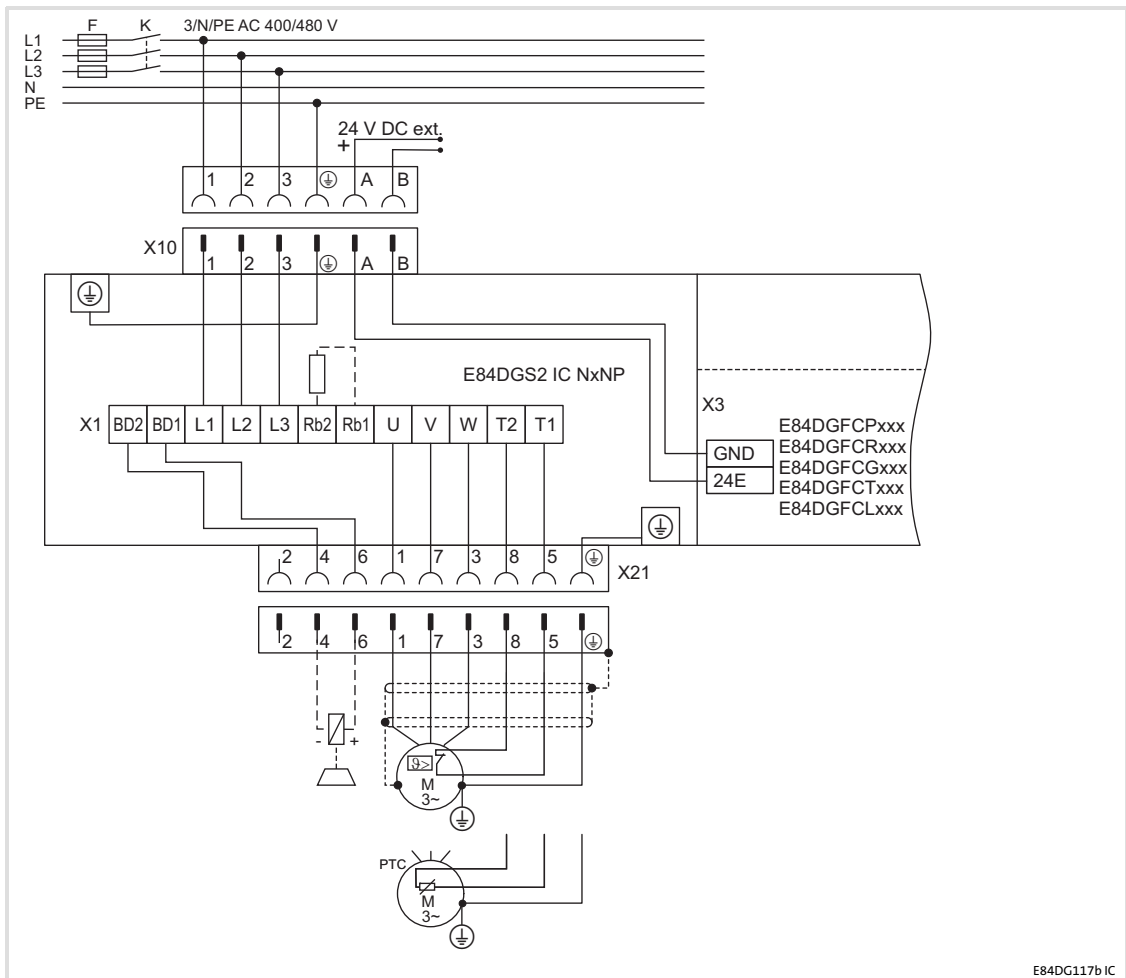

E84DG117b IC

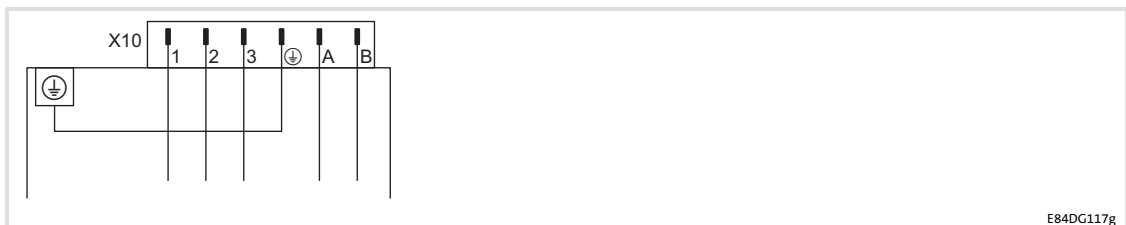

E84DG117g

X10		$U_{max}$	$I_{max}$
	1	L1	480 V AC 16 A
	2	L2	
	3	L3	
	A	24 V ext.	24 V DC 10 A
	B	GND	
	⊕	PE	

E84DGX10M15

# Installation

Power terminals  
Wall mounting without switch

## E84DGS2 KC N<sub>x</sub>NP

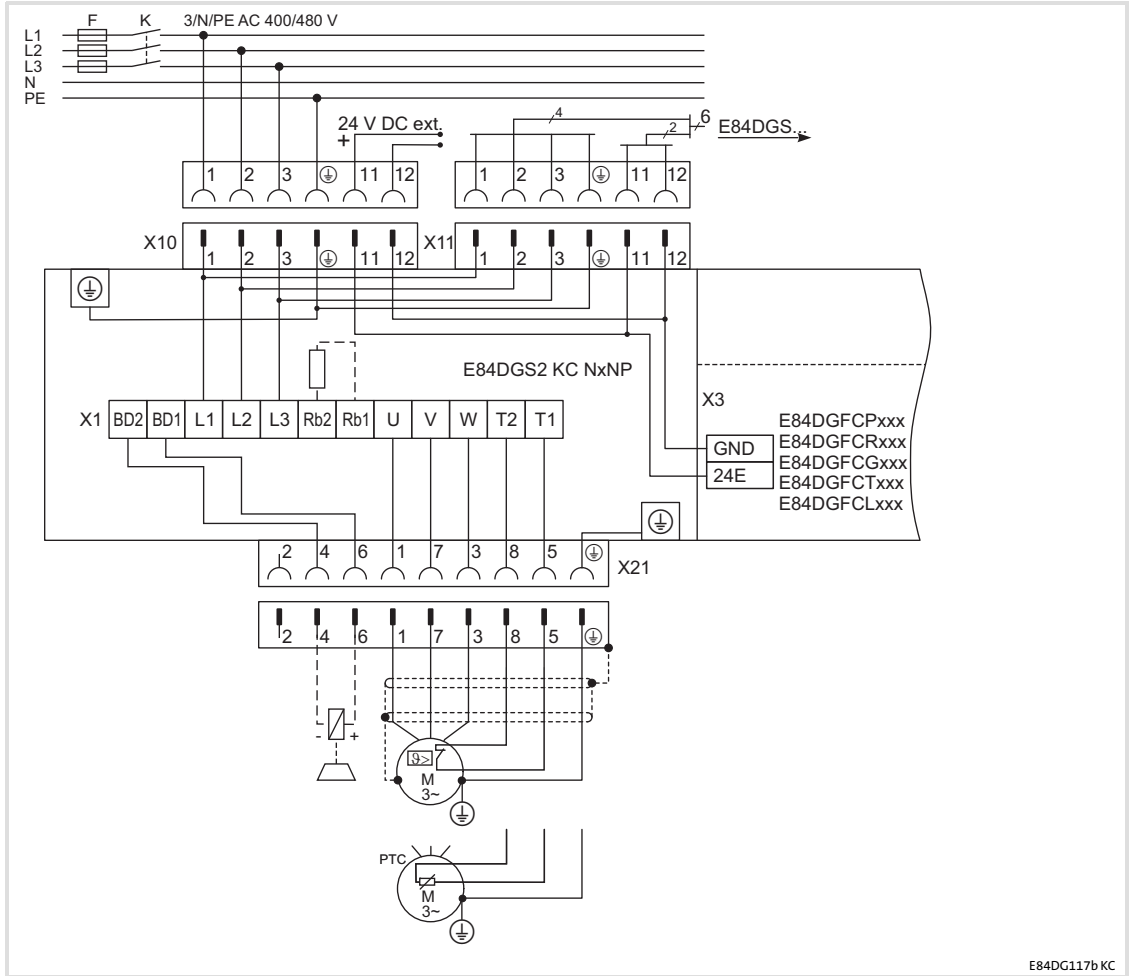

E84DG117b KC

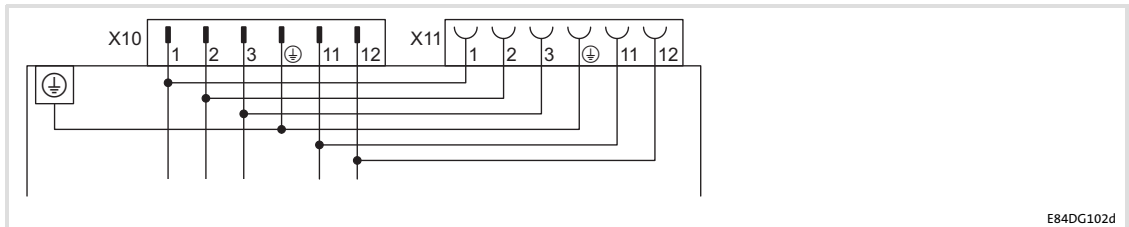

E84DG102d

X10		U <sub>max</sub>	I <sub>max</sub>	
<p>84DWTX0100</p>	1	L1	480 V AC	32 A
	2	L2		
	3	L3		
	⊕	PE		
	11	24 V DC	24 V DC	10 A
	12	GND		

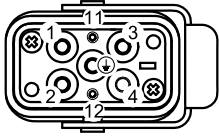
X11		$U_{max}$	$I_{max}$	
 <p>84DWTX0110</p>	1	L1'	480 V AC	32 A
	2	L2'		
	3	L3'		
	⊕	PE		
	11	24 V DC	24 V DC	10 A
	12	GND		

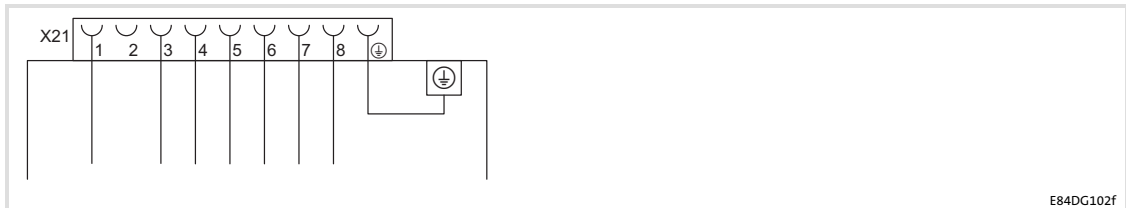

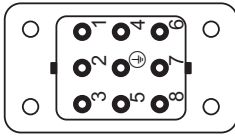
X21		$U_{max}$	
 <p>84DWTX0100</p>	2	–	480 V AC
	1	U	
	7	V	
	3	W	
	4	BD2	
	6	BD1	
	5	T1	
	8	T2	
	⊕	PE	

# Installation

Power terminals  
Wall mounting without switch

## E84DGS2 KC NMNP

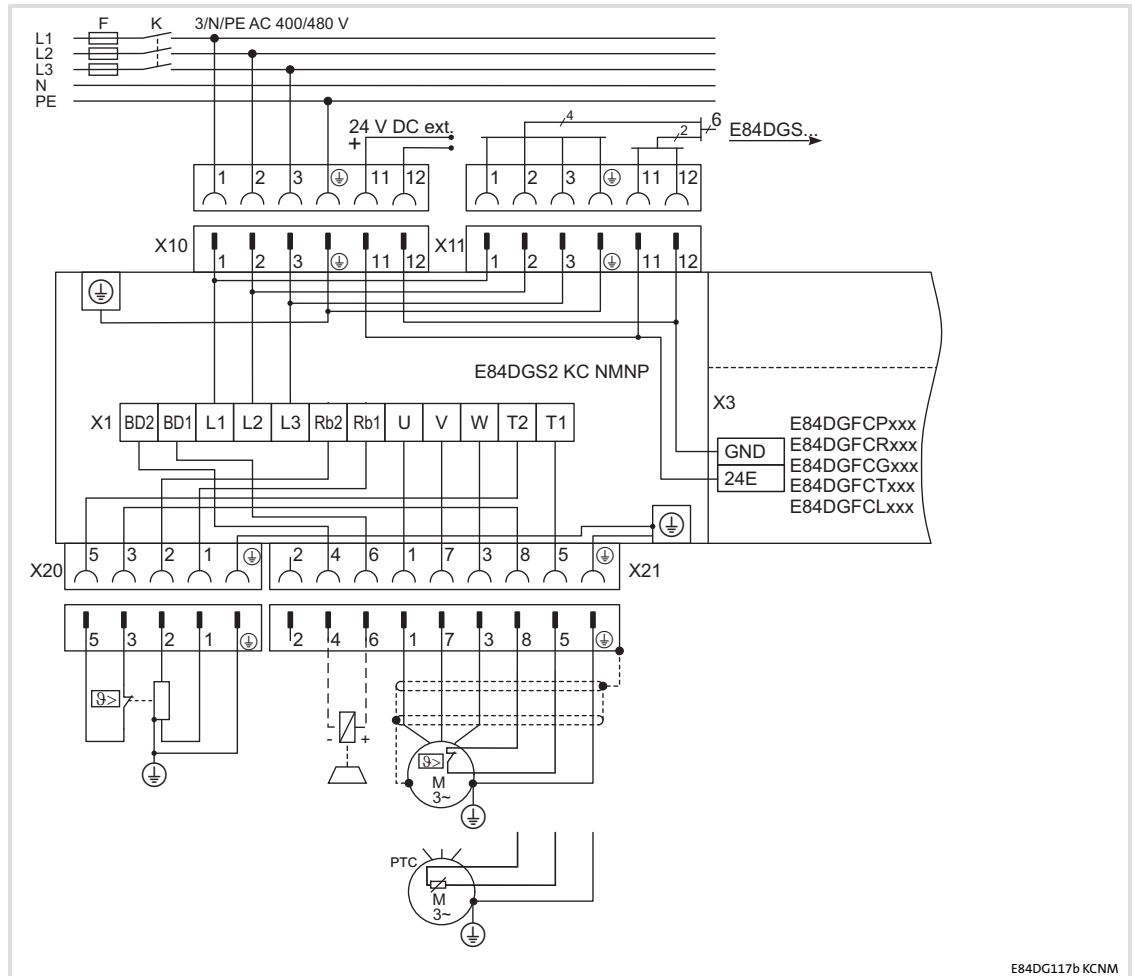

E84DG117b KCNM

### X20

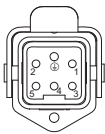

E84DZEV086\_x

1	RB1
2	RB2
4	-
3	T1
5	T2
⊕	PE

**Wandmontage 4 ... 7.5 kW**

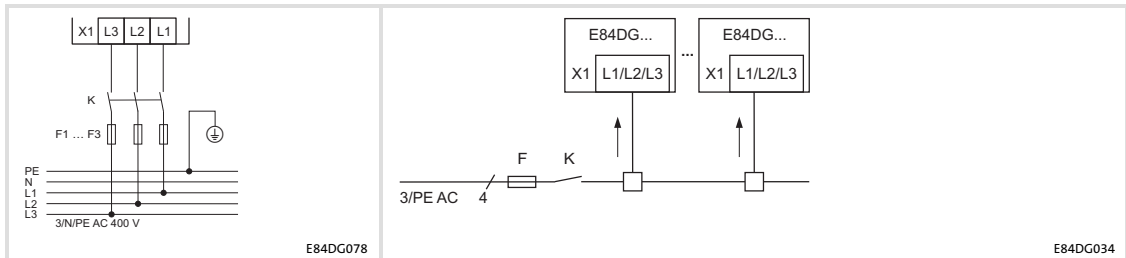
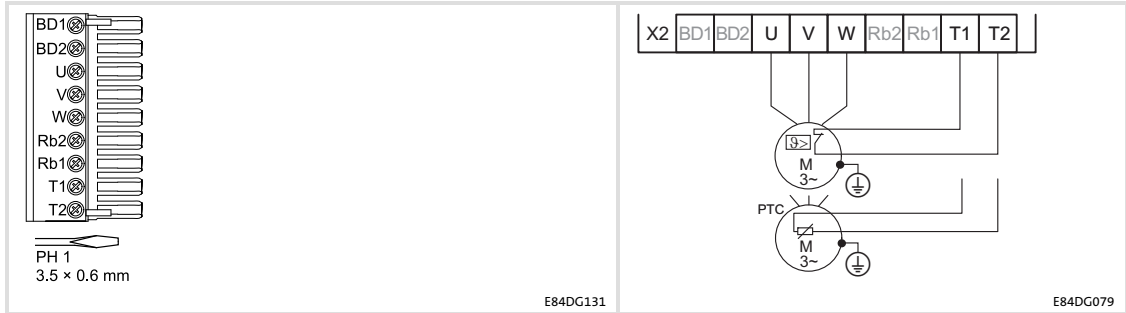

**5.8.4 Product extensions**

For wall mounting, the 8400 motec in the power range of 4 ... 7.5 kW can be electrically installed by means of plug-in modules.

The plug-in modules are optionally available as separate accessories.

The plug-in modules **E84DZEVbxCNP** and **E84DZEVbLCFP** are not suitable for operation with increased rated power of 9.2 kW.

**E84DZEVbxCNP**

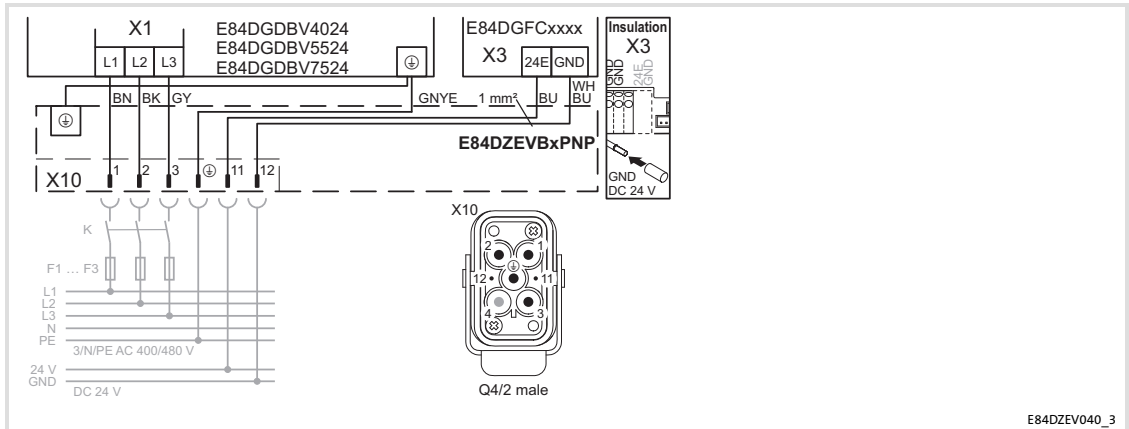

**E84DZEVbxPRP**

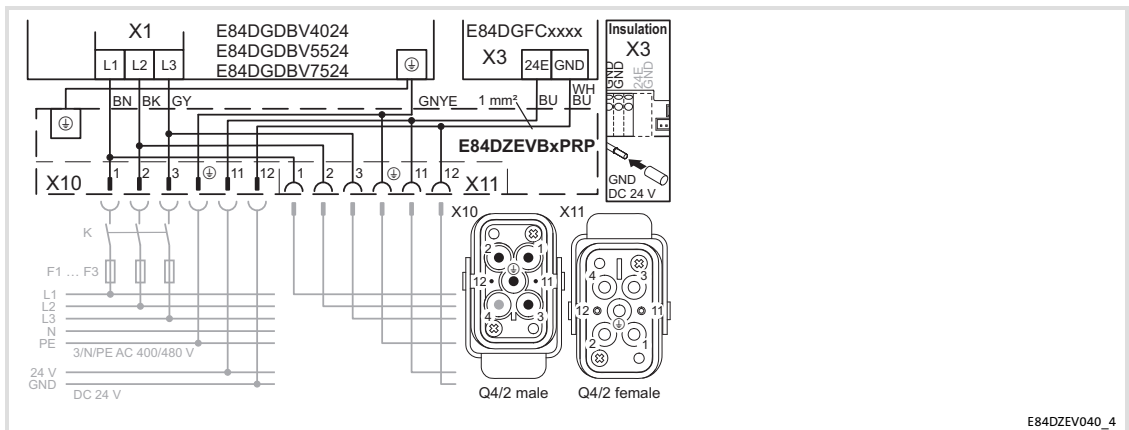

**E84DZEV BxCNP**

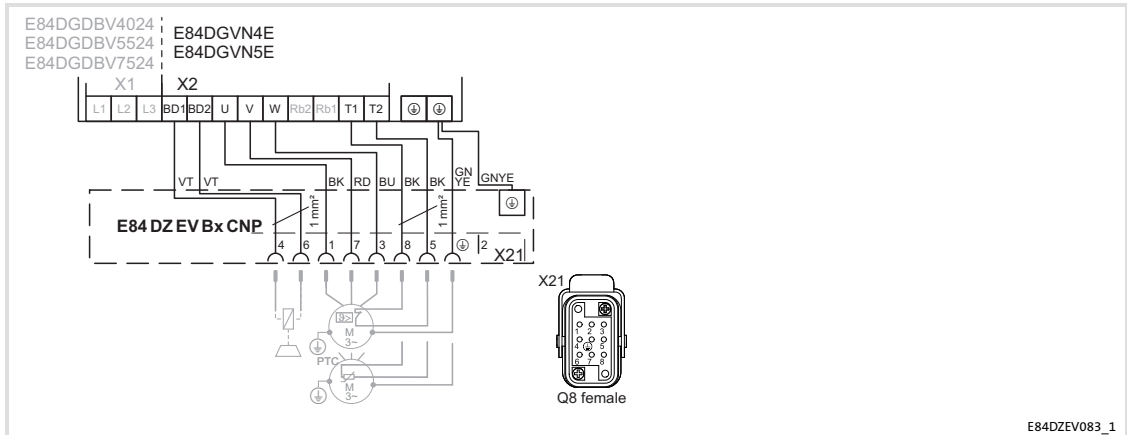

**E84DZEV BLCFP**

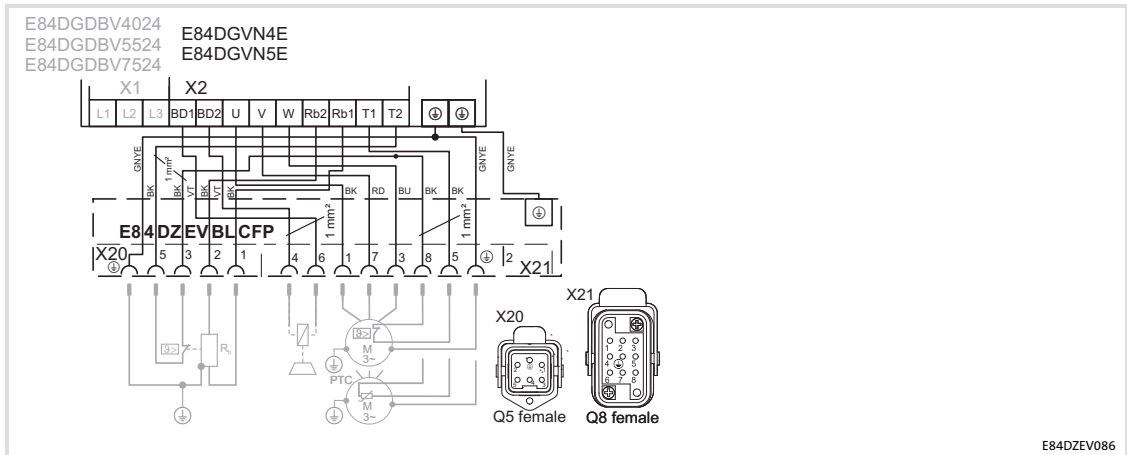

## 5.8.5 Wall mounting with switch

## Wandmontage 0.37 ... 3 kW

For wall mounting, the electrical installation of 8400 motec with switch depends on the variant features of the Frame Unit.

- ▶ Connection system:
  - Cable gland (E84DGS3 LE ...)
  - Pluggable (E84DGS3 KC ...)
- ▶ The type of switch or combination:
  - Service switch (E84DGS3xx B ...)
  - Service switch with protective function (E84DGS3xx K ...)
  - Service switch with control elements (E84DGS3xx E ...)
- ▶ Brake resistor option:
  - Not integrated (E84DGS3xxx N ...)
  - Integrated (E84DGS3xxx C ...)
  - External, connectable via plugs Q5/0 (E84DGS3xxx L ...)

## E84DGS3LEBxND

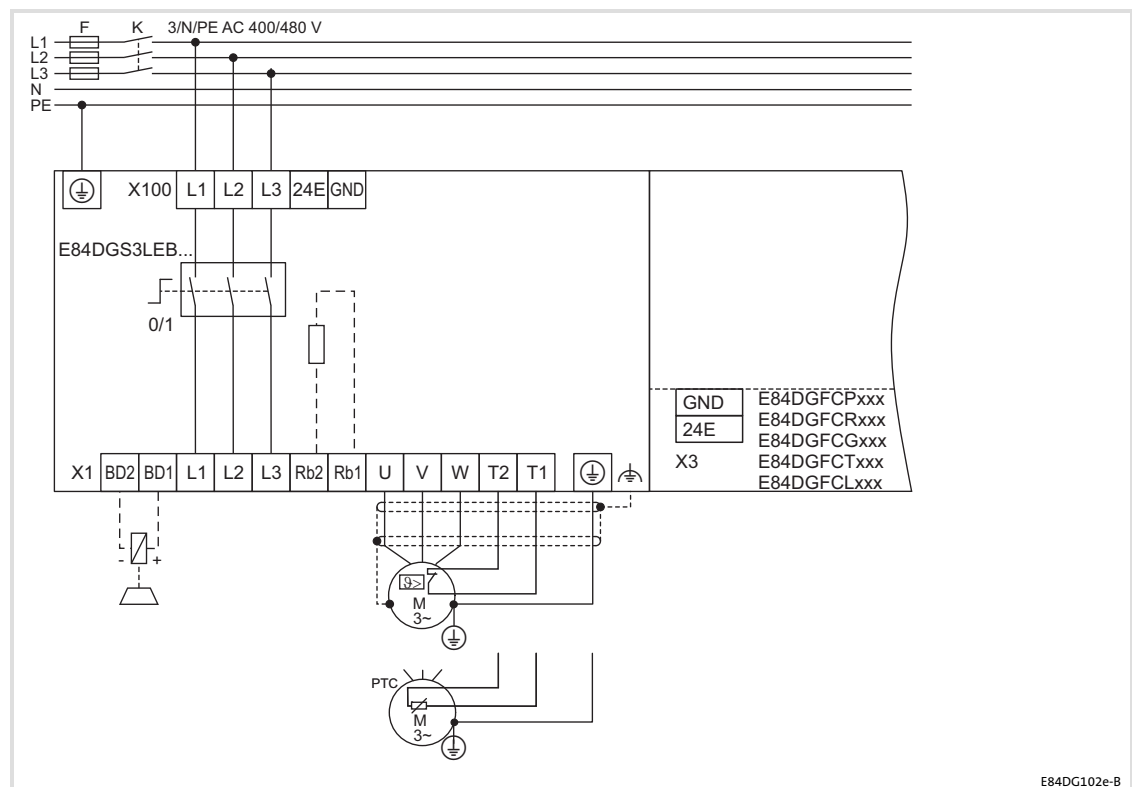



# Installation

Power terminals

Wall mounting with switch

## E84DGS3LEKxND

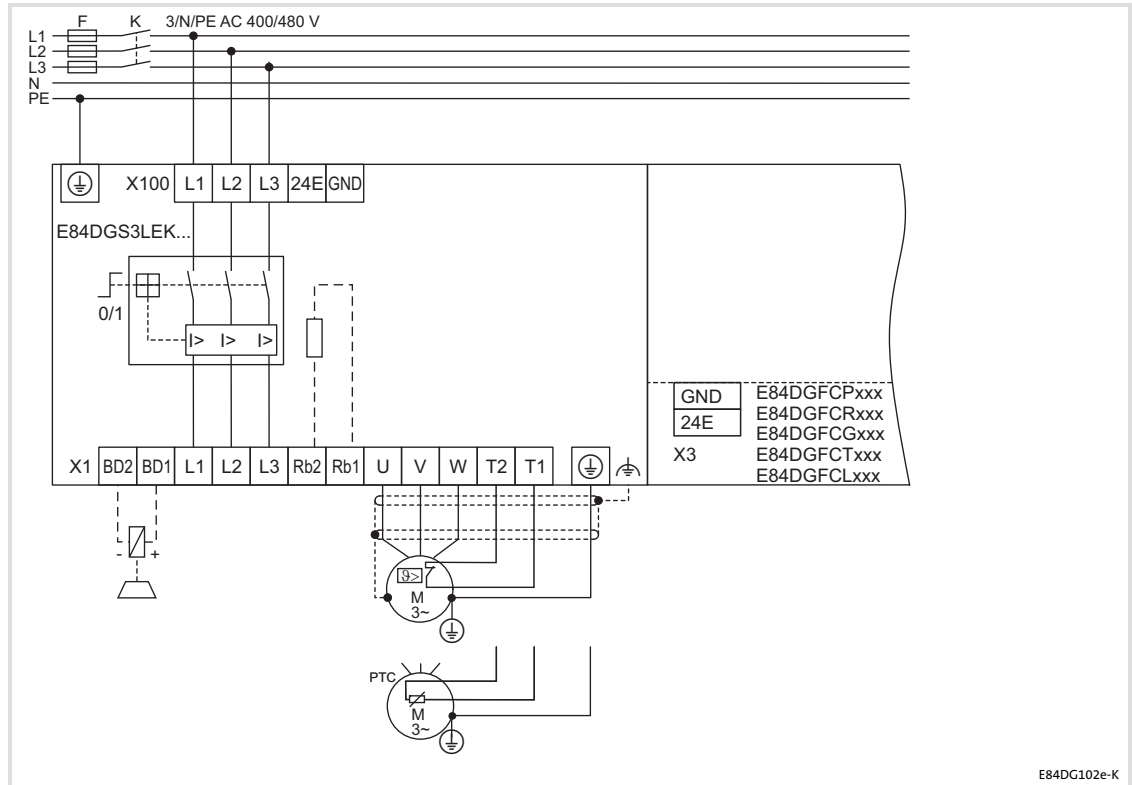

E84DG102e-K

5.8.6

E84DGS3 KC xxND

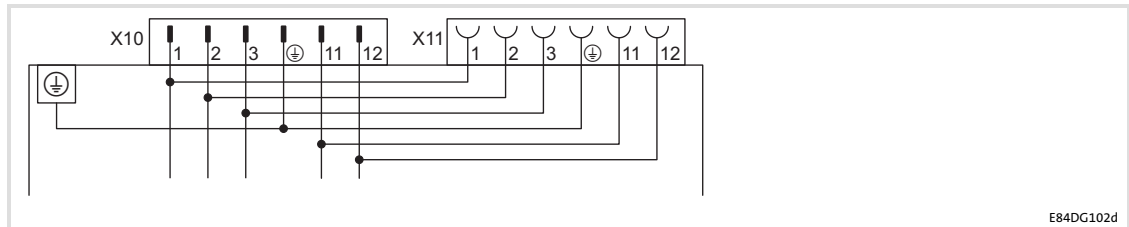

E84DG102d

X10			$U_{max}$	$I_{max}$
<p>84DWTX0100</p>	1	L1	480 V AC	32 A
	2	L2		
	3	L3		
	⊕	PE	24 V DC	10 A
	11	24 V DC		
	12	GND		

X11			$U_{max}$	$I_{max}$
<p>84DWTX0110</p>	1	L1'	480 V AC	32 A
	2	L2'		
	3	L3'		
	⊕	PE	24 V DC	10 A
	11	24 V DC		
	12	GND		

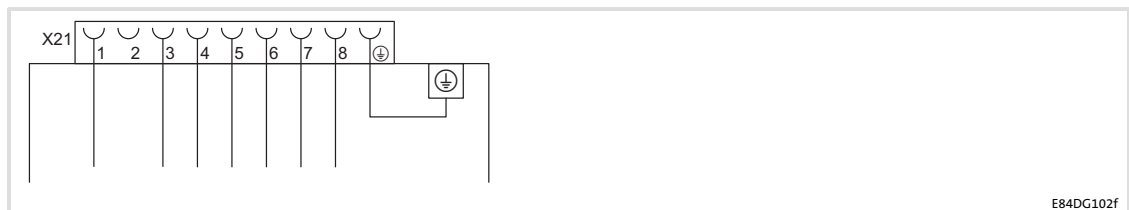

E84DG102f

X21			$U_{max}$
<p>84DWTX0100</p>	2	–	480 V AC
	1	U	
	7	V	
	3	W	
	4	BD2	
	6	BD1	
	5	T1	
	8	T2	
	⊕	PE	



5.8.8

E84DGS3KCExND

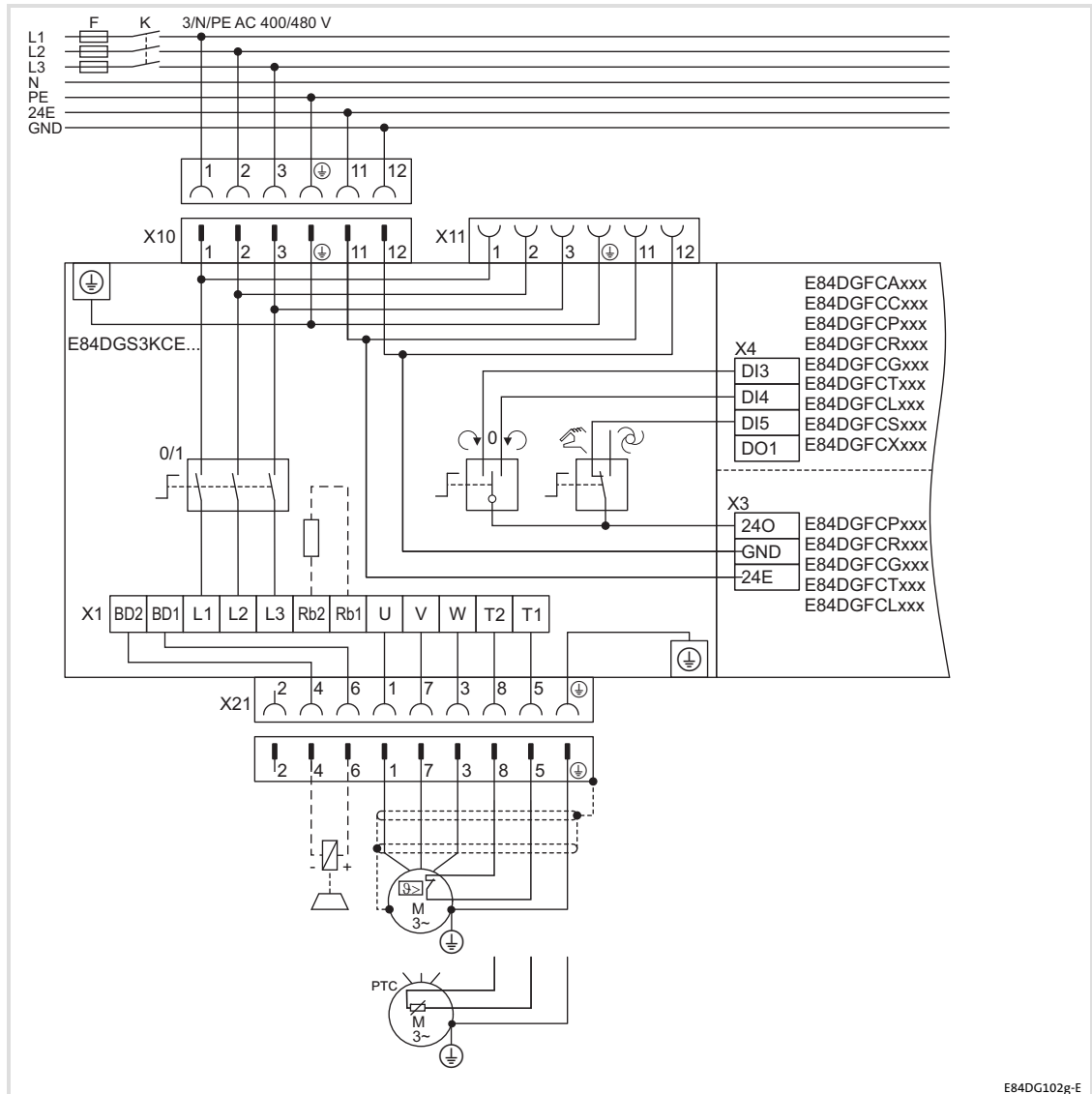

E84DG102g-E

5.8.9

**E84DGS3KCKxND**

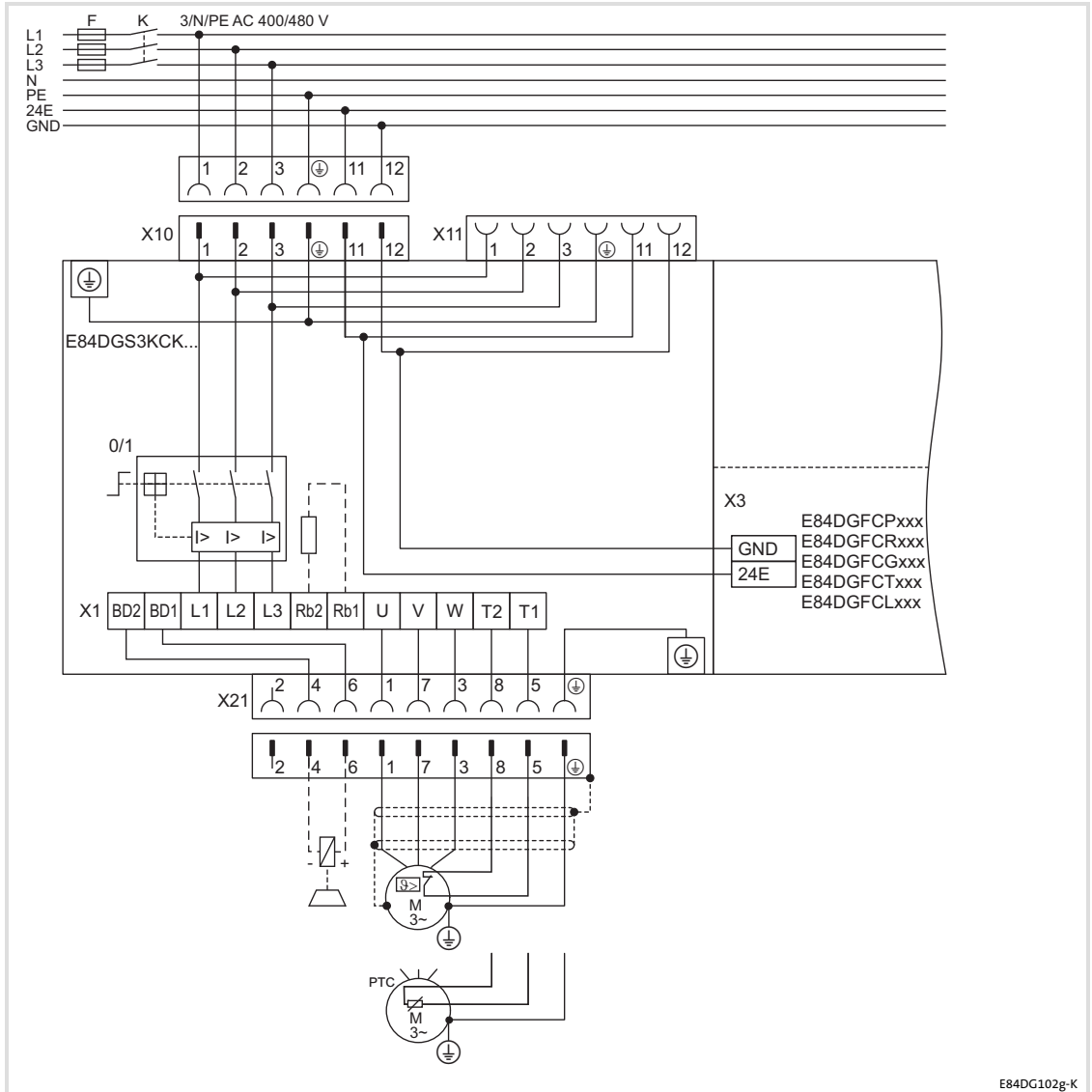

**E84DGS3 KC xLND**

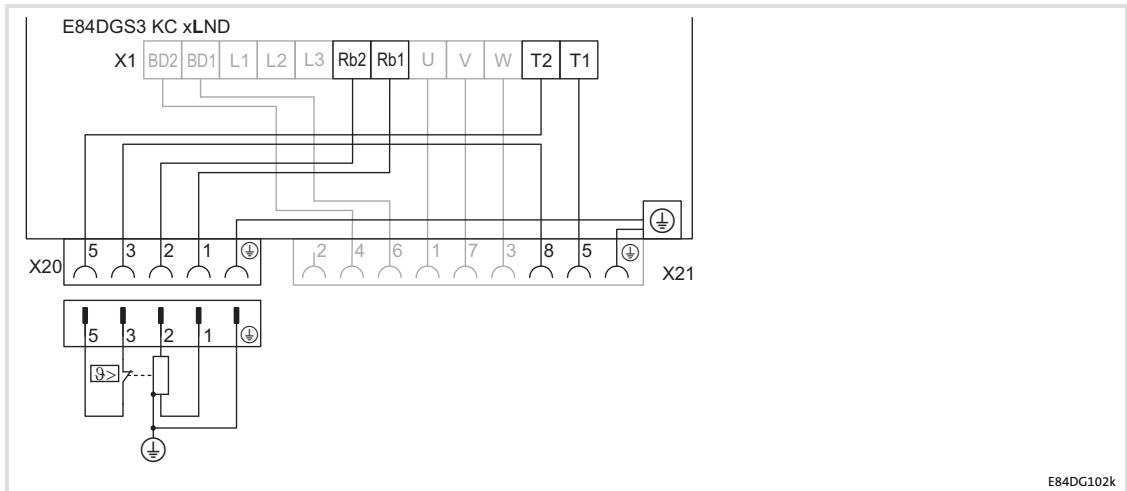

**X20**

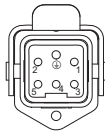

E84DZEV086\_x

1	RB1	
2	RB2	
4	-	
3	T1	
5	T2	
⊕	PE	



5.9.2 Standard I/O

Terminals

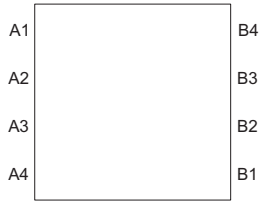
Mode	Features			Position of M12 plug
Standard I/O E84DGFC5NNP	Controller enable	RFR	1	
	Digital inputs	DIx	5	
	Digital outputs	DOx	1	
	Analog inputs	AU/AI	1	
	Relay	NO	1	
	STO safety function	STO	–	
	External 24 V supply	24E	–	

E84DG126a

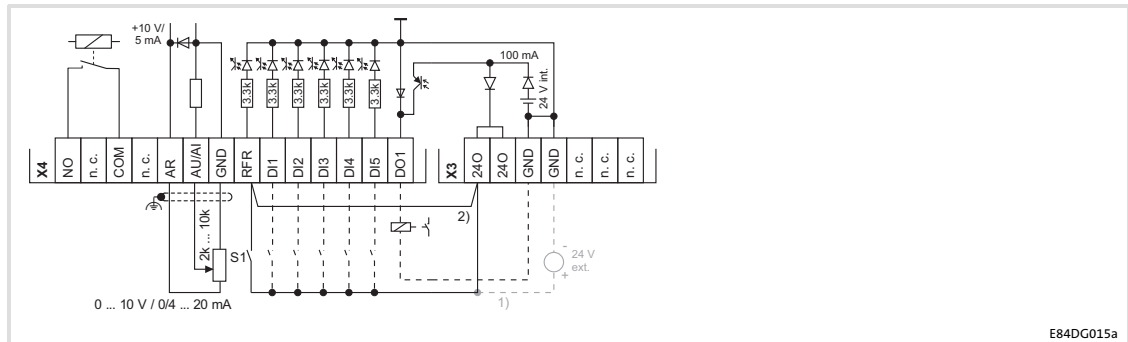

E84DG015a

- 1) External alternative voltage supply
- 2) Wire jumper for permanent controller enable (delivery state)

**5.9.3 Standard I/O + M12**

**Terminals**

Mode	Features			Position of M12 plug
<b>Standard I/O + M12</b> E84DGFC51NP	Controller enable	RFR	1	
	Digital inputs	DIx	5	
	Digital outputs	DOx	1	
	Analog inputs	AU/AI	1	
	Relay	NO	1	
	STO safety function	STO	–	
	External 24 V supply	24E	–	

E84DG126k

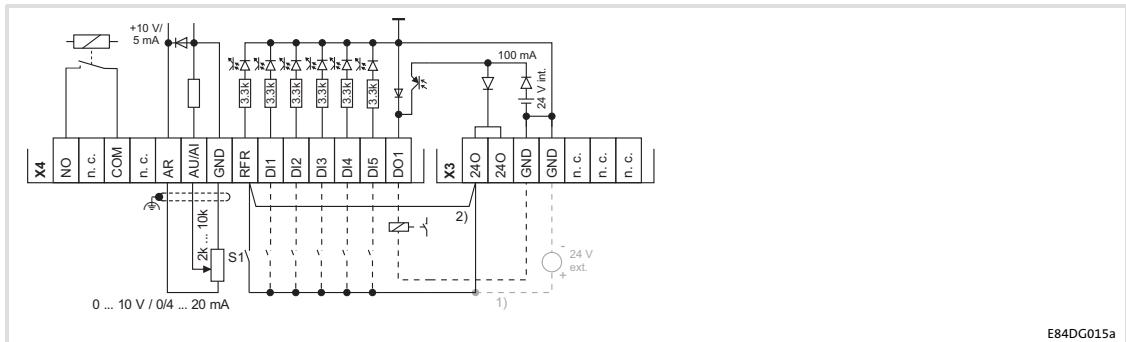

E84DG015a

- 1) External alternative voltage supply
- 2) Wire jumper for permanent controller enable (delivery state)

E84DGFC51NP	•		•	
	A1		A2	
<p>M12 female socket A-Coding</p>	1	24O	1	24O
	2	DI2	2	DI3
	3	GND	3	GND
	4	DI1	4	DO1
	5	n. c.	5	n. c.

### 5.9.4 Extended I/O

#### Terminals

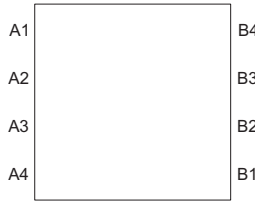
Mode	Features			Position of M12 plug
Extended I/O E84DGFCXNNP	Controller enable	RFR	1	
	Digital inputs	DIx	8	
	Digital outputs	DOx	1	
	Analog inputs	AxU	2	
	Relay	NO	1	
	STO safety function	STO	—	
	External 24 V supply	24E	—	

E84DG126a

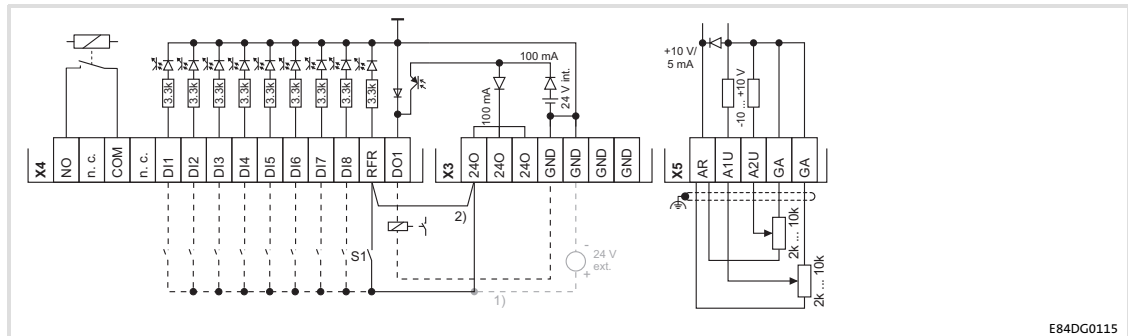

E84DG0115

- 1) External alternative voltage supply
- 2) Wire jumper for permanent controller enable (delivery state)

5.9.5

**AS-Interface**

**Terminals**

Mode	Features			Position of M12 plug
<b>AS interface</b> E84DGFCFNP	Controller enable	RFR	1	
	Digital inputs	DIx	5	
	Digital outputs	DOx	1	
	Analog inputs	AU/AI	—	
	Relay	NO	—	
	STO safety function	STO	—	
	External 24 V supply	24E	—	

E84DG126c

Mode	Features			Position of M12 plug
<b>AS interface Enhanced</b> E84DGFCFENP	Controller enable	RFR	1	
	Digital inputs	DIx	5	
	Digital outputs	DOx	1	
	Analog inputs	AU/AI	—	
	Relay	NO	—	
	STO safety function	STO	—	
	External 24 V supply	24E	—	

E84DG126g

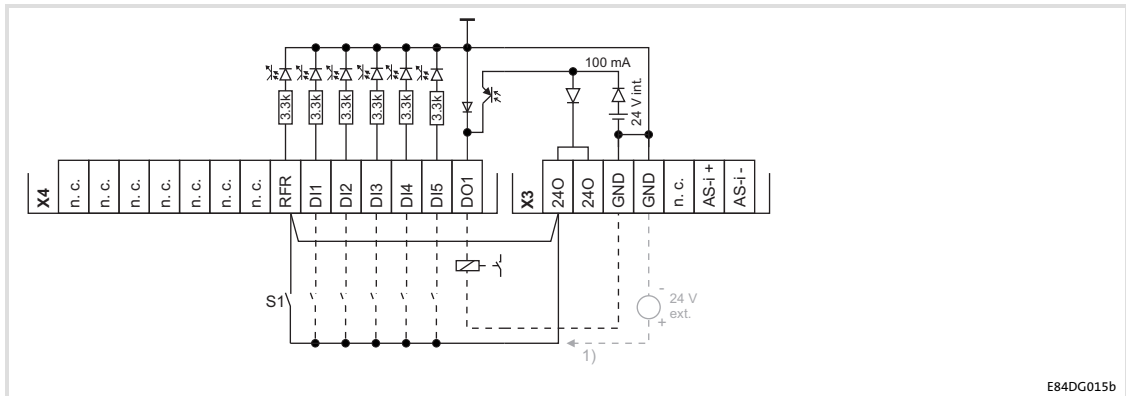

- 1) External alternative voltage supply
- 2) Wire jumper for permanent controller enable (delivery state)

**Assignment of M12 plug**

A2	Assignment
<p>M12 male socket A-coding</p>	1 ASI IN
	2 n. c.
	3 ASI OUT
	4 n. c.
	5 n. c.

<b>E84DGFCxFNx</b>	•			
<b>E84DGFCxENx</b>	•		•	
	A4		B4	
 <p>M12 female socket A-Coding</p>	1	24O	1	24O
	2	DI2	2	DI3
	3	GND	3	GND
	4	DI1	4	DO1
	5	n. c.	5	n. c.

5.9.6

**AS-Interface STO**

**Terminals**

Mode	Features	Position of M12 plug	
<b>AS-Interface STO</b> E84DGFCFJP	Controller enable	RFR	1
	Digital inputs	DIx	5
	Digital outputs	DOx	1
	Analog inputs	AU/AI	1
	Relay	NO	1
	STO safety function	STO	1
	External 24 V supply	24E	–

A1	LED	B4
A2	Bus	B3
A3		B2
A4	DI1/DI2	B1

E84DG126c

Mode	Features	Position of M12 plug	
<b>AS-Interface STO Enhanced</b> E84DGFCAEJP	Controller enable	RFR	1
	Digital inputs	DIx	5
	Digital outputs	DOx	1
	Analog inputs	AU/AI	1
	Relay	NO	1
	STO safety function	STO	1
	External 24 V supply	24E	–

A1	LED	Safety	B4
A2	Bus	NO/DO1	B3
A3		AU/AI	B2
A4	DI1/DI2		B1

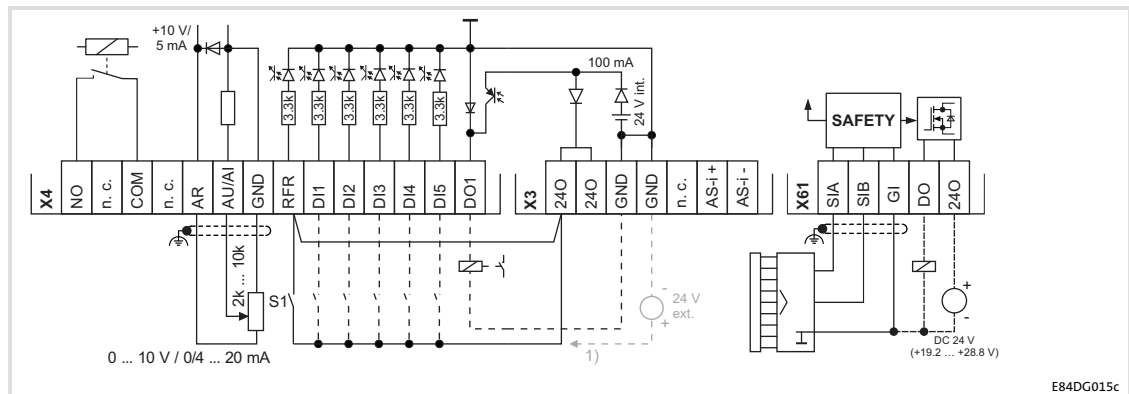

E84DG126d



- 1) External alternative voltage supply
- 2) Wire jumper for permanent controller enable (delivery state)

**Assignment of M12 plug**

A2	Assignment
 M12 male socket A-coding	1 ASI IN
	2 n. c.
	3 ASI OUT
	4 n. c.
	5 n. c.

<b>E84DGFCxFJx</b>		•							
<b>E84DGFCxEJx</b>		•		•	•		•		
		A4		B2	B3		B4		
 <p>M12 female socket A-Coding</p>	1	24O	 <p>M12 female socket A-Coding</p>	1	24O	24O	 <p>M12 male socket A-Coding</p>	1	SIA
	2	DI2		2	AU/AI	DO1		2	SIB
	3	GND		3	GND	GND		3	DO
	4	DI1		4	AR	COM		4	24O
	5	n. c.		5	n. c.	NO		5	GI

5.9.7

**CANopen®**

**Terminals**

Mode	Features			Position of M12 plug
<b>CANopen</b> E84DGFCFNP	Controller enable	RFR	1	
	Digital inputs	DIx	5	
	Digital outputs	DOx	1	
	Analog inputs	AU/AI	—	
	Relay	NO	—	
	STO safety function	STO	—	
	External 24 V supply	24E	—	

E84DG126e

Mode	Features			Position of M12 plug
<b>CANopen Enhanced</b> E84DGFCENP	Controller enable	RFR	1	
	Digital inputs	DIx	5	
	Digital outputs	DOx	1	
	Analog inputs	AU/AI	—	
	Relay	NO	—	
	STO safety function	STO	—	
	External 24 V supply	24E	—	

E84DG126h

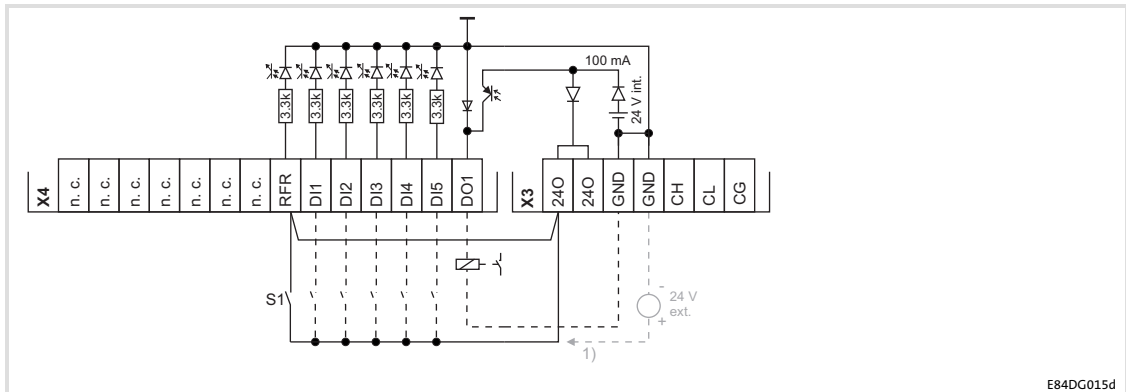



E84DG015d

- 1) External alternative voltage supply
- 2) Wire jumper for permanent controller enable (delivery state)

**Assignment of M12 plug**

A2	Assignment	A3	Assignment
<p>M12 male socket A-coding</p>	1 n. c.	<p>M12 female socket A-coding</p>	1 n. c.
	2 n. c.		2 n. c.
	3 CG		3 CG
	4 CH		4 CH
	5 CL		5 CL

<b>E84DGFCxFNx</b>	•				
<b>E84DGFCxENx</b>	•		•		
	A4		B4		
 M12 female socket A-Coding	1	24O	 M12 female socket A-Coding	1	24O
	2	DI2		2	DI3
	3	GND		3	GND
	4	DI1		4	DO1
	5	n. c.		5	n. c.

5.9.8

**CANopen® STO**

**Terminals**

Mode	Features	Position of M12 plug		
<b>CANopen STO</b> E84DGFCCFJP	Controller enable	RFR	1	
	Digital inputs	DIx	5	
	Digital outputs	DOx	1	
	Analog inputs	AU/AI	1	
	Relay	NO	1	
	STO safety function	STO	1	
	External 24 V supply	24E	–	

E84DG126e

Mode	Features	Position of M12 plug		
<b>CANopen STO Enhanced</b> E84DGFCEJP	Controller enable	RFR	1	
	Digital inputs	DIx	5	
	Digital outputs	DOx	1	
	Analog inputs	AU/AI	1	
	Relay	NO	1	
	STO safety function	STO	1	
	External 24 V supply	24E	–	

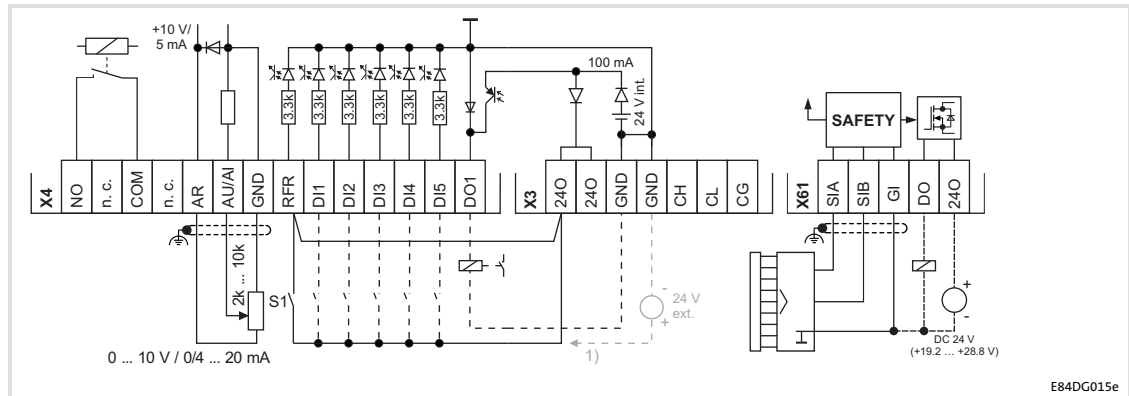

E84DG126i



- 1) External alternative voltage supply
- 2) Wire jumper for permanent controller enable (delivery state)

**Assignment of M12 plug**

A2	Assignment	A3	Assignment
<p>M12 male socket A-coding</p>	1 n. c.	<p>M12 female socket A-coding</p>	1 n. c.
	2 n. c.		2 n. c.
	3 CG		3 CG
	4 CH		4 CH
	5 CL		5 CL

E84DGFCxFJx		•							
E84DGFCxEJx		•		•		•		•	
		A4		B2		B3		B4	
 <p>M12 female socket A-Coding</p>	1	24O	 <p>M12 female socket A-Coding</p>	1	24O	24O	 <p>M12 male socket A-Coding</p>	1	SIA
	2	DI2		2	AU/AI	DO1		2	SIB
	3	GND		3	GND	GND		3	DO
	4	DI1		4	AR	COM		4	24O
	5	n. c.		5	n. c.	NO		5	GI

5.9.9

**EtherCAT®**

**Terminals**

Mode	Features			Position of M12 plug
EtherCAT E84DGCTFNP	Controller enable	RFR	1	
	Digital inputs	DIx	5	
	Digital outputs	DOx	1	
	Analog inputs	AU/AI	—	
	Relay	NO	—	
	STO safety function	STO	—	
	External 24 V supply	24E	1	

E84DG126f

Mode	Features			Position of M12 plug
EtherCAT Enhanced E84DGCTENP	Controller enable	RFR	1	
	Digital inputs	DIx	5	
	Digital outputs	DOx	1	
	Analog inputs	AU/AI	—	
	Relay	NO	—	
	STO safety function	STO	—	
	External 24 V supply	24E	1	

E84DG126j

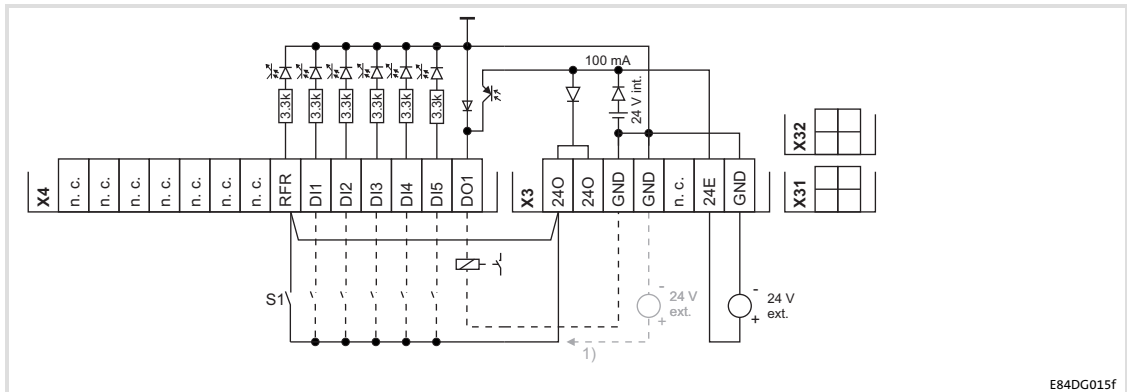

- 1) External alternative voltage supply
- 2) Wire jumper for permanent controller enable (delivery state)

**Assignment of M12 plug**

A2	Assignment	A3	Assignment
<p>M12 female socket D-coding</p>	1 TX+	<p>M12 female socket D-coding</p>	1 TX+
	2 Rx+		2 Rx+
	3 Tx -		3 Tx -
	4 RX-		4 RX-
	5 Contact plate		5 Contact plate

<b>E84DGFCxFNx</b>	•			
<b>E84DGFCxENx</b>	•		•	
	A4		B4	
 <p>M12 female socket A-Coding</p>	1	24O	1	24O
	2	DI2	2	DI3
	3	GND	3	GND
	4	DI1	4	DO1
	5	n. c.	5	n. c.

**5.9.10 EtherCAT® STO**

**Terminals**

Mode	Features			Position of M12 plug
EtherCAT STO E84DGFTFJP	Controller enable	RFR	1	
	Digital inputs	DIx	5	
	Digital outputs	DOx	1	
	Analog inputs	AU/AI	1	
	Relay	NO	1	
	STO safety function	STO	1	
	External 24 V supply	24E	1	

E84DG126f

Mode	Features			Position of M12 plug
EtherCAT STO Enhanced E84DGFTJJP	Controller enable	RFR	1	
	Digital inputs	DIx	5	
	Digital outputs	DOx	1	
	Analog inputs	AU/AI	1	
	Relay	NO	1	
	STO safety function	STO	1	
	External 24 V supply	24E	1	

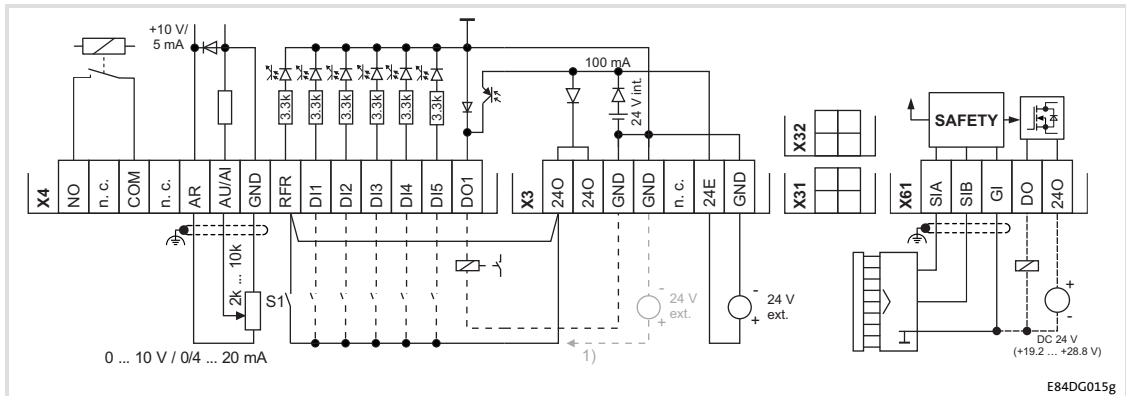

E84DG126b



- 1) External alternative voltage supply
- 2) Wire jumper for permanent controller enable (delivery state)

**Assignment of M12 plug**

A2	Assignment	A3	Assignment
<p>M12 female socket D-coding</p>	1 TX+	<p>M12 female socket D-coding</p>	1 TX+
	2 Rx+		2 Rx+
	3 Tx -		3 Tx -
	4 RX-		4 RX-
	5 Contact plate		5 Contact plate

E84DGFCxFJx		•							
E84DGFCxEJx		•		•		•		•	
		A4				B2		B3	
								B4	
 M12 female socket A-Coding	1	24O	 M12 female socket A-Coding	1	24O	24O	 M12 male socket A-Coding	1	SIA
	2	DI2		2	AU/AI	DO1		2	SIB
	3	GND		3	GND	GND		3	DO
	4	DI1		4	AR	COM		4	24O
	5	n. c.		5	n. c.	NO		5	GI

**5.9.11 EtherNet/IP™**

**Terminals**

Mode	Features			Position of M12 plug
EtherNet/IP E84DGFCGFNP	Controller enable	RFR	1	
	Digital inputs	DIx	5	
	Digital outputs	DOx	1	
	Analog inputs	AU/AI	—	
	Relay	NO	—	
	STO safety function	STO	—	
	External 24 V supply	24E	1	

E84DG126f

Mode	Features			Position of M12 plug
EtherNet/IP Enhanced E84DGFCGENP	Controller enable	RFR	1	
	Digital inputs	DIx	5	
	Digital outputs	DOx	1	
	Analog inputs	AU/AI	—	
	Relay	NO	—	
	STO safety function	STO	—	
	External 24 V supply	24E	1	

E84DG126j

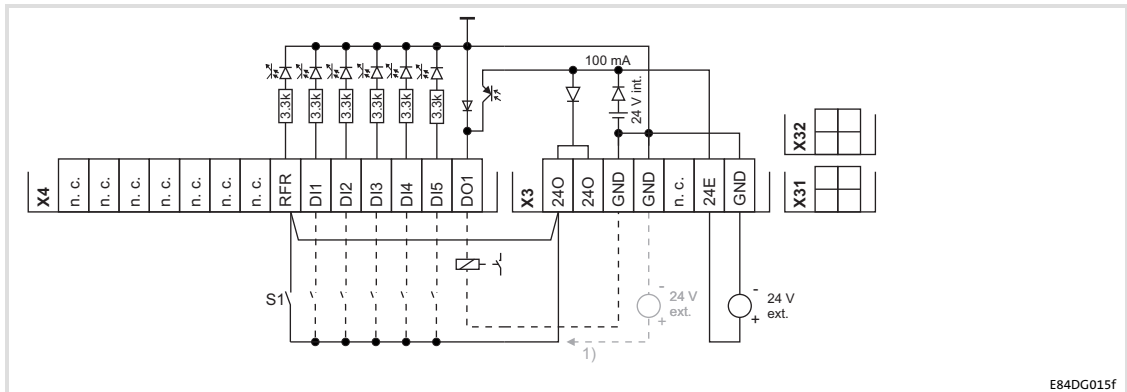

- 1) External alternative voltage supply
- 2) Wire jumper for permanent controller enable (delivery state)

**Assignment of M12 plug**

A2	Assignment	A3	Assignment
<p>M12 female socket D-coding</p>	1 TX+	<p>M12 female socket D-coding</p>	1 TX+
	2 Rx+		2 Rx+
	3 Tx -		3 Tx -
	4 RX-		4 RX-
	5 Contact plate		5 Contact plate

<b>E84DGFCxFNx</b>	•			
<b>E84DGFCxENx</b>	•		•	
	A4		B4	
 <p>M12 female socket A-Coding</p>	1	24O	1	24O
	2	DI2	2	DI3
	3	GND	3	GND
	4	DI1	4	DO1
	5	n. c.	5	n. c.

**5.9.12 EtherNet/IP™ STO**

**Terminals**

Mode	Features			Position of M12 plug
<b>EtherNET/IP STO</b> E84DGFCGFJP	Controller enable	RFR	1	
	Digital inputs	DIx	5	
	Digital outputs	DOx	1	
	Analog inputs	AU/AI	1	
	Relay	NO	1	
	STO safety function	STO	1	
	External 24 V supply	24E	1	

E84DG126f

Mode	Features			Position of M12 plug
<b>EtherNET/IP STO Enhanced</b> E84DGFCGEJP	Controller enable	RFR	1	
	Digital inputs	DIx	5	
	Digital outputs	DOx	1	
	Analog inputs	AU/AI	1	
	Relay	NO	1	
	STO safety function	STO	1	
	External 24 V supply	24E	1	

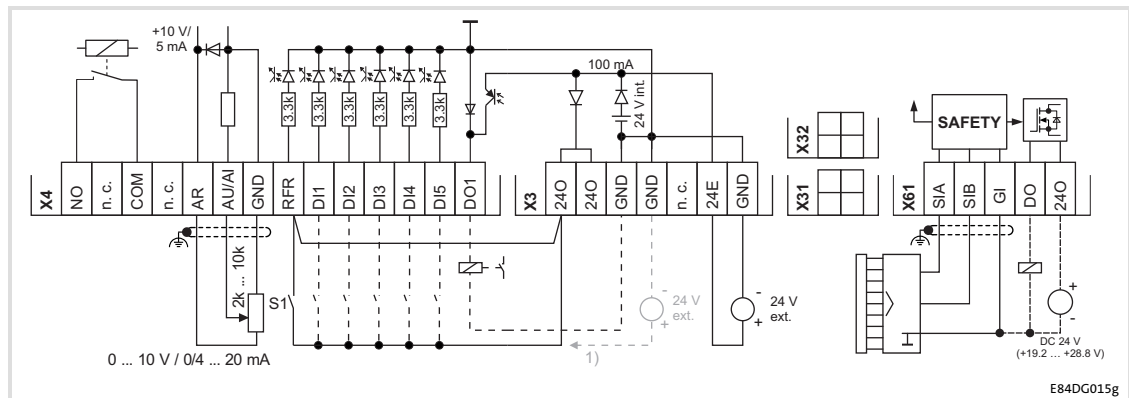

E84DG126b



- 1) External alternative voltage supply
- 2) Wire jumper for permanent controller enable (delivery state)

**Assignment of M12 plug**

A2	Assignment	A3	Assignment
<p>M12 female socket D-coding</p>	1 TX+	<p>M12 female socket D-coding</p>	1 TX+
	2 Rx+		2 Rx+
	3 Tx -		3 Tx -
	4 RX-		4 RX-
	5 Contact plate		5 Contact plate

E84DGFCxFJx		•							
E84DGFCxEJx		•		•		•		•	
		A4				B2		B3	
								B4	
 <p>M12 female socket A-Coding</p>	1	24O	 <p>M12 female socket A-Coding</p>	1	24O	24O	 <p>M12 male socket A-Coding</p>	1	SIA
	2	DI2		2	AU/AI	DO1		2	SIB
	3	GND		3	GND	GND		3	DO
	4	DI1		4	AR	COM		4	24O
	5	n. c.		5	n. c.	NO		5	GI

**5.9.13 PROFIBUS®**

**Terminals**

Mode	Features			Position of M12 plug
<b>PROFIBUS</b> E84DGFCFNP	Controller enable	RFR	1	
	Digital inputs	DIx	5	
	Digital outputs	DOx	1	
	Analog inputs	AU/AI	—	
	Relay	NO	—	
	STO safety function	STO	—	
	External 24 V supply	24E	1	

E84DG126f

Mode	Features			Position of M12 plug
<b>PROFIBUS Enhanced</b> E84DGFCPENP	Controller enable	RFR	1	
	Digital inputs	DIx	5	
	Digital outputs	DOx	1	
	Analog inputs	AU/AI	—	
	Relay	NO	—	
	STO safety function	STO	—	
	External 24 V supply	24E	1	

E84DG126j

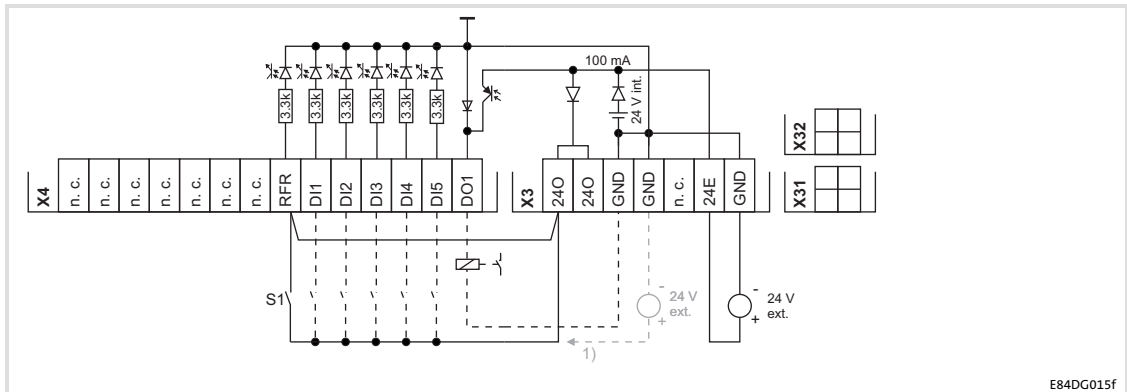

- 1) External alternative voltage supply
- 2) Wire jumper for permanent controller enable (delivery state)

**Assignment of M12 plug**

A2	Assignment	A3	Assignment
<p>M12 male socket B-coding</p>	1 n. c.	<p>M12 female socket B-coding</p>	1 PSV2
	2 Channel A		2 Channel A
	3 n. c.		3 GND
	4 Channel B		4 Channel B
	5 n. c.		5 n. c.

<b>E84DGFCxFNx</b>	•			
<b>E84DGFCxENx</b>	•		•	
	A4		B4	
 <p>M12 female socket A-Coding</p>	1	240	1	240
	2	DI2	2	DI3
	3	GND	3	GND
	4	DI1	4	DO1
	5	n. c.	5	n. c.

**5.9.14 PROFIBUS® STO**

**Terminals**

Mode	Features			Position of M12 plug
<b>PROFIBUS STO</b> E84DGFCPJF	Controller enable	RFR	1	
	Digital inputs	DIx	5	
	Digital outputs	DOx	1	
	Analog inputs	AU/AI	1	
	Relay	NO	1	
	STO safety function	STO	1	
	External 24 V supply	24E	1	

E84DG126f

Mode	Features			Position of M12 plug
<b>PROFIBUS STO Enhanced</b> E84DGFCPEJP	Controller enable	RFR	1	
	Digital inputs	DIx	5	
	Digital outputs	DOx	1	
	Analog inputs	AU/AI	1	
	Relay	NO	1	
	STO safety function	STO	1	
	External 24 V supply	24E	1	

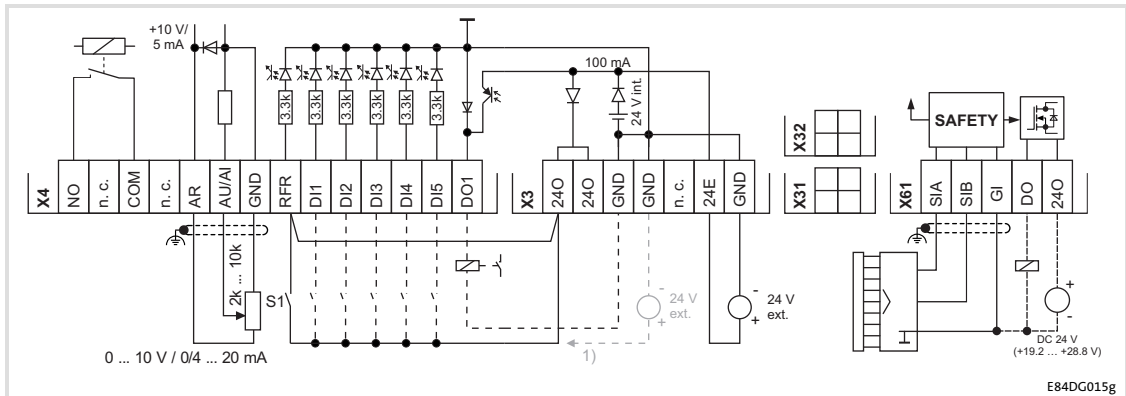

E84DG126b



- 1) External alternative voltage supply
- 2) Wire jumper for permanent controller enable (delivery state)

**Assignment of M12 plug**

A2	Assignment	A3	Assignment
<p>M12 male socket B-coding</p>	1 n. c.	<p>M12 female socket B-coding</p>	1 PSV2
	2 Channel A		2 Channel A
	3 n. c.		3 GND
	4 Channel B		4 Channel B
	5 n. c.		5 n. c.

E84DGFCxFJx		•							
E84DGFCxEJx		•		•		•		•	
		A4				B2		B3	
								B4	
 <p>M12 female socket A-Coding</p>	1	24O	 <p>M12 female socket A-Coding</p>	1	24O	24O	 <p>M12 male socket A-Coding</p>	1	SIA
	2	DI2		2	AU/AI	DO1		2	SIB
	3	GND		3	GND	GND		3	DO
	4	DI1		4	AR	COM		4	24O
	5	n. c.		5	n. c.	NO		5	GI

**5.9.15 PROFINET®**

**Terminals**

Mode	Features			Position of M12 plug
<b>PROFINET</b> E84DGFCRFNP	Controller enable	RFR	1	
	Digital inputs	DIx	5	
	Digital outputs	DOx	1	
	Analog inputs	AU/AI	—	
	Relay	NO	—	
	STO safety function	STO	—	
	External 24 V supply	24E	1	

E84DG126f

Mode	Features			Position of M12 plug
<b>PROFINET Enhanced</b> E84DGFCRENP	Controller enable	RFR	1	
	Digital inputs	DIx	5	
	Digital outputs	DOx	1	
	Analog inputs	AU/AI	—	
	Relay	NO	—	
	STO safety function	STO	—	
	External 24 V supply	24E	1	

E84DG126j

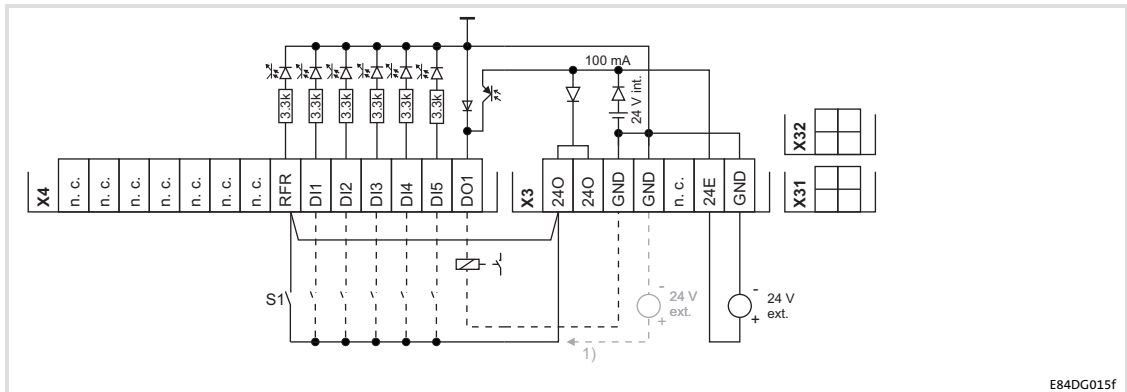

- 1) External alternative voltage supply
- 2) Wire jumper for permanent controller enable (delivery state)

**Assignment of M12 plug**

A2	Assignment	A3	Assignment
<p>M12 female socket D-coding</p>	1 TX+	<p>M12 female socket D-coding</p>	1 TX+
	2 Rx+		2 Rx+
	3 Tx -		3 Tx -
	4 RX-		4 RX-
	5 Contact plate		5 Contact plate

<b>E84DGFCxFNx</b>	•			
<b>E84DGFCxENx</b>	•		•	
	A4		B4	
 <p>M12 female socket A-Coding</p>	1	24O	1	24O
	2	DI2	2	DI3
	3	GND	3	GND
	4	DI1	4	DO1
	5	n. c.	5	n. c.

**5.9.16 PROFINET® STO**

**Terminals**

Mode	Features			Position of M12 plug
<b>PROFINET STO</b> E84DGFCRFJP	Controller enable	RFR	1	
	Digital inputs	DIx	5	
	Digital outputs	DOx	1	
	Analog inputs	AU/AI	1	
	Relay	NO	1	
	STO safety function	STO	1	
	External 24 V supply	24E	1	

E84DG126f

Mode	Features			Position of M12 plug
<b>PROFINET STO Enhanced</b> E84DGFCREJP	Controller enable	RFR	1	
	Digital inputs	DIx	5	
	Digital outputs	DOx	1	
	Analog inputs	AU/AI	1	
	Relay	NO	1	
	STO safety function	STO	1	
	External 24 V supply	24E	1	

E84DG126b

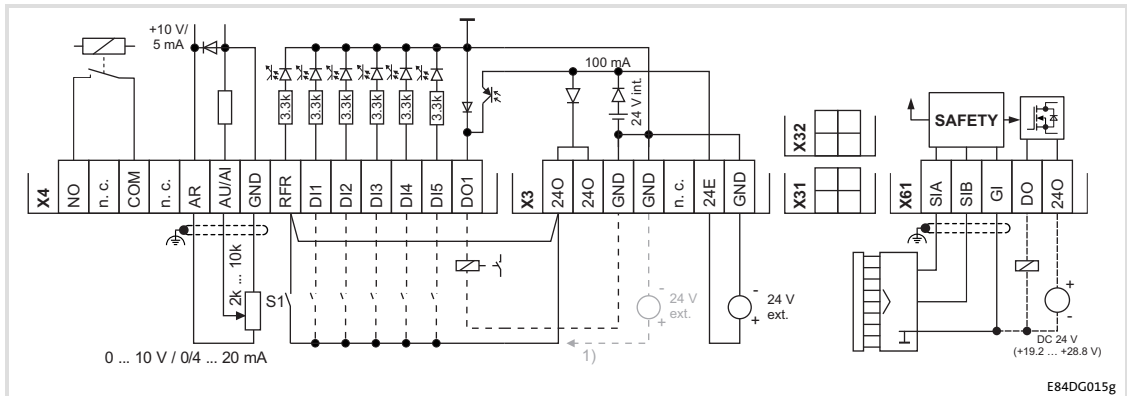

- 1) External alternative voltage supply
- 2) Wire jumper for permanent controller enable (delivery state)

**Assignment of M12 plug**

A2	Assignment	A3	Assignment
<p>M12 female socket D-coding</p>	1 TX+	<p>M12 female socket D-coding</p>	1 TX+
	2 Rx+		2 Rx+
	3 Tx -		3 Tx -
	4 RX-		4 RX-
	5 Contact plate		5 Contact plate

E84DGFCxFJx	•						
E84DGFCxEJx	•		•	•		•	
	A4		B2	B3		B4	
 M12 female socket A-Coding	1	24O	1	24O	24O	1	SIA
	2	DI2	2	AU/AI	DO1	2	SIB
	3	GND	3	GND	GND	3	DO
	4	DI1	4	AR	COM	4	24O
	5	n. c.	5	n. c.	NO	5	GI

5.9.17

**POWERLINK**

**Terminals**

Mode	Features			Position of M12 plug
<b>POWERLINK</b> E84DGFCLNP	Controller enable	RFR	1	
	Digital inputs	DIx	5	
	Digital outputs	DOx	1	
	Analog inputs	AU/AI	—	
	Relay	NO	—	
	STO safety function	STO	—	
	External 24 V supply	24E	1	

E84DG126f

Mode	Features			Position of M12 plug
<b>POWERLINK Enhanced</b> E84DGFLENP	Controller enable	RFR	1	
	Digital inputs	DIx	5	
	Digital outputs	DOx	1	
	Analog inputs	AU/AI	—	
	Relay	NO	—	
	STO safety function	STO	—	
	External 24 V supply	24E	1	

E84DG126j

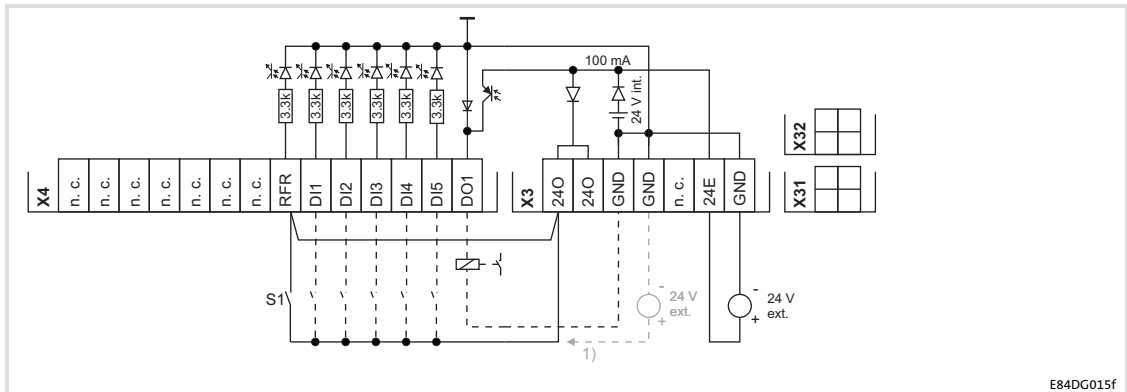

- 1) External alternative voltage supply
- 2) Wire jumper for permanent controller enable (delivery state)

**Assignment of M12 plug**

A2	Assignment	A3	Assignment
<p>M12 female socket D-coding</p>	1 TX+	<p>M12 female socket D-coding</p>	1 TX+
	2 Rx+		2 Rx+
	3 Tx -		3 Tx -
	4 RX-		4 RX-
	5 Contact plate		5 Contact plate

<b>E84DGFCxFNx</b>	•			
<b>E84DGFCxENx</b>	•		•	
	A4		B4	
 <p>M12 female socket A-Coding</p>	1	24O	1	24O
	2	DI2	2	DI3
	3	GND	3	GND
	4	DI1	4	DO1
	5	n. c.	5	n. c.

**5.9.18 POWERLINK STO**

**Terminals**

Mode	Features			Position of M12 plug
<b>POWERLINK STO</b> E84DGFCLFJP	Controller enable	RFR	1	
	Digital inputs	DIx	5	
	Digital outputs	DOx	1	
	Analog inputs	AU/AI	1	
	Relay	NO	1	
	STO safety function	STO	1	
	External 24 V supply	24E	1	

E84DG126f

Mode	Features			Position of M12 plug
<b>POWERLINK STO Enhanced</b> E84DGFCLFJP	Controller enable	RFR	1	
	Digital inputs	DIx	5	
	Digital outputs	DOx	1	
	Analog inputs	AU/AI	1	
	Relay	NO	1	
	STO safety function	STO	1	
	External 24 V supply	24E	1	

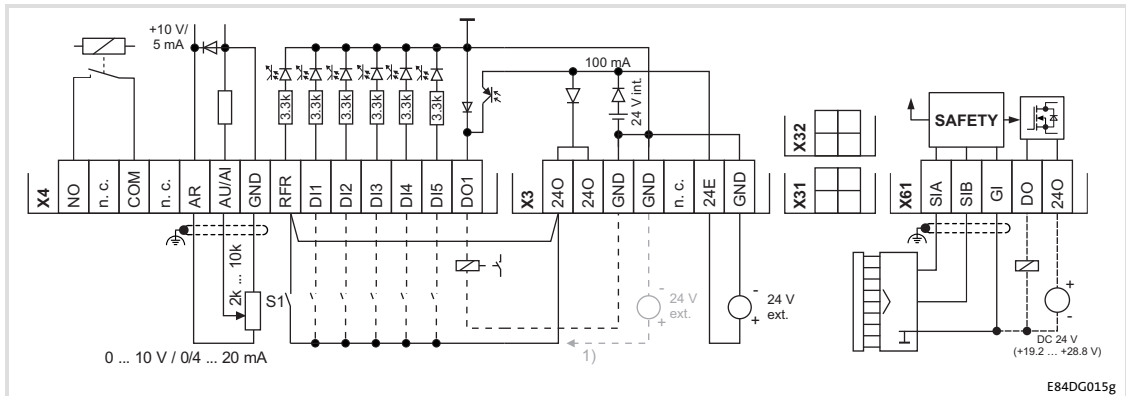

E84DG126b



- 1) External alternative voltage supply
- 2) Wire jumper for permanent controller enable (delivery state)

**Assignment of M12 plug**

A2	Assignment	A3	Assignment
<p>M12 female socket D-coding</p>	1 TX+	<p>M12 female socket D-coding</p>	1 TX+
	2 Rx+		2 Rx+
	3 Tx -		3 Tx -
	4 RX-		4 RX-
	5 Contact plate		5 Contact plate

E84DGFCxFJx		•							
E84DGFCxEJx		•		•		•		•	
		A4				B2		B3	
								B4	
 <p>M12 female socket A-Coding</p>	1	24O	 <p>M12 female socket A-Coding</p>	1	24O	24O	 <p>M12 male socket A-Coding</p>	1	SIA
	2	DI2		2	AU/AI	DO1		2	SIB
	3	GND		3	GND	GND		3	DO
	4	DI1		4	AR	COM		4	24O
	5	n. c.		5	n. c.	NO		5	GI

## 6 Commissioning

Before you start

## 6 Commissioning



### Note!

- ▶ Please observe the general safety instructions (📖 13).
- ▶ Please observe the notes regarding residual hazards (📖 19).

### 6.1 Before you start

#### Selection of the appropriate commissioning tool



### Tip!

Use the »Engineer« to carry out extensive parameter setting and configuration. The online help which is available for each device and the accompanying software documentation will assist you.

The 8400 motec keypad (diagnosis terminal version) can be used for quick commissioning and checking individual parameters on the controller.

#### Low rotating field frequency with a self-ventilated motor



### Danger!

- ▶ For thermal reasons, continuous operation of self-ventilated motors at low field frequency and rated motor current is not permissible. If required, activate a motor temperature monitoring with C00585
  - motor temperature monitoring with I<sup>2</sup>xt (see software manual)
  - motor temperature monitoring with motor PTC (see software manual).
- ▶ When setting the V/f base frequency (C00015), please observe the following difference to the 8400 StateLine/HighLine/TopLine controllers:  
For the 8400 motec drive, the reference voltage for the V/f base frequency is the rated motor voltage (C00090) according to the motor nameplate (independently of the line-side supply voltage).

#### Fan for 4 ... 7.5 kW Drive Unit



### Note!

If the heatsink temperature of the 4 ... 7.5 kW Drive Unit exceeds a permanently defined limit value, the fans of the Drive Unit will switch on automatically.

- ▶ The limit value for the temperature monitoring function is defined in the device and cannot be parameterised.



**Tip!**

In the Lenze setting, the VFCplus motor control (V/f characteristic control) with linear characteristic is set in C00006.

- ▶ VFCplus is especially suitable for the operation of machines with a linear or square-law load torque characteristic (e. g. fan).
- ▶ The parameters are preset so that, with an inverter that is adapted in terms of power and a 50 Hz motor, the inverter is ready for operation without further parameterisation and the motor is working satisfactorily.

Recommendations for the following application cases:

- ▶ Inverter and motor differing strongly in terms of power:
  - Set code C00022 ( $I_{\max}$  limit in motor mode) to  $2 \times I_{\text{rated}}$  motor.
- ▶ High starting torque:
  - Set code C00016 (Vmin boost) in no-load operation of the motor, so that the rated motor current is flowing with a rotating field frequency  $f = 3$  Hz (C00058).
- ▶ Noise optimisation:
  - Set code C00018 to the value "3" (switching frequency 16 kHz).
- ▶ High torque at low speeds (without feedback):
  - Select "Vector control" operating mode.

**Danger!**

**After power-off, wait at least three minutes before working on the inverter.  
When removing the memory module, ensure that the inverter is deenergised.**

All parameters of the drive system are saved non-volatily on the memory module. These include the parameters of the inverter and communication-relevant parameters for the communication unit used.

The plug-in version is especially suited for

- ▶ restoring an application after replacing a device,
- ▶ duplicating identical drive tasks within the 8400 motec frequency inverter series, e.g. by using the EPM Programmer that is optionally available.

0.37 ... 3 kW

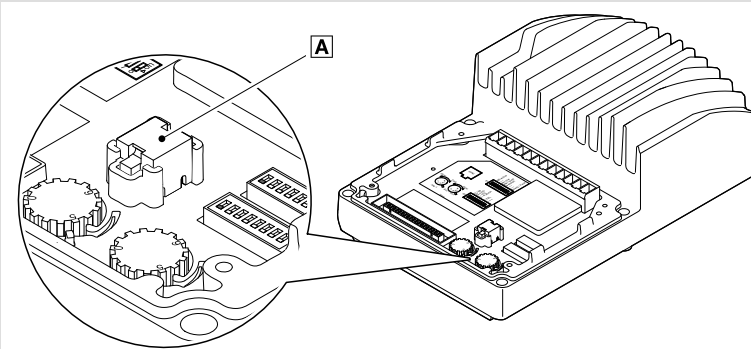

E84DG128

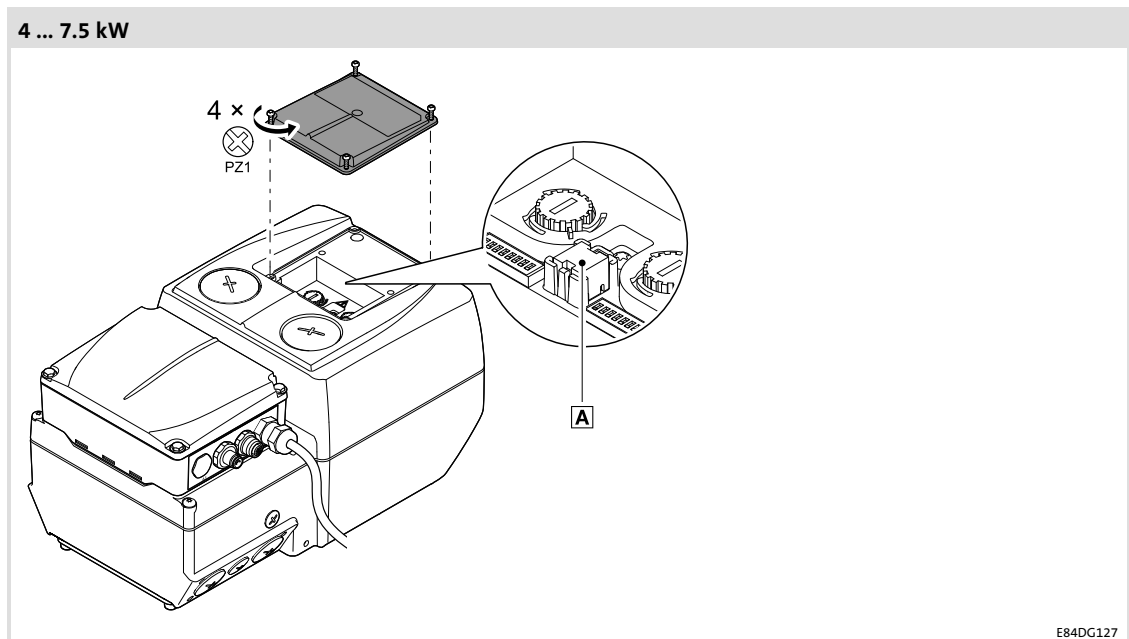

**A** Memory module, pluggable



### Note!

- ▶ When the device is switched on, all parameters are automatically loaded from the memory module to the main memory of the inverter.
  - If DIP1/1 is in the ON position, the inverter works with the settings made via DIP1 and DIP2 and shows these settings in the corresponding codes.
- ▶ The 8400 BaseLine and 8400 motec inverters use the same (grey) memory module. The memory module can be shifted between these inverters, however, the corresponding inverter must be reparameterised afterwards.

When handling the memory module, a distinction is drawn between the following scenarios:

#### Delivery status

- ▶ The memory module is plugged into the EPM slot of the drive unit.
- ▶ The Lenze setting of the parameters is stored in the memory module.
- ▶ The memory module is available as a spare part – without any data contents–.

#### During operation

Parameter sets can be saved manually.

- ▶ Parameter sets can be loaded manually.
- ▶ Parameter changes can be saved automatically.

**6.3 Commissioning via DIP switch/potentiometer****Stop!****Automatic motor start**

In "Local mode" The auto-start option "Inhibit at power-on" is not set. When the mains is connected, the motor starts if the controller enable RFR is bridged or set.

("Local mode" => DIP1/1 = ON and DIP2/5-7 = OFF)

**Possible consequences:**

- ▶ Danger or damages through unexpected motor start.

**Protective measures:**

- ▶ Decouple the motor from the drive train during commissioning phase.
- ▶ Replace the factory-set bridge at RFR by an NO contact.
- ▶ Do not set controller enable.

For initial commissioning, settings can be made via DIP switch and potentiometer. The settings must be made before mounting the drive unit since the setting elements cannot be accessed from the outside.

From software version 07.00.00 onwards, you can use DIP2/8 to set two different pre-assignments of DIP1, DIP2, P1, P2, and P3:

- ▶ DIP2/8 = OFF: DIP switch/ potentiometer assignment 0
- ▶ DIP2/8 = ON: DIP switch/ potentiometer assignment 1

Up to software version 07.00.00, only DIP switch/ potentiometer assignment 0 is available.

From software version 08.00.00 onwards and when using a POWERLINK communication module, you can influence the IP address setting with DIP1/1:

- ▶ DIP1/1 = OFF: DIP1/2 ... DIP1/8, P1, P2 and P3 are inactive, DIP2 serves to set the IP addresses for POWERLINK
- ▶ DIP1/1 = ON: DIP switch function and potentiometer assignment as described, IP address setting from code C13899

Detailed information can be found in the POWERLINK (EDS84DMOTPL) communication manual.

### Setting elements 0.37 ... 3 kW

The setting elements are located on the inner side of the drive unit.

Settings carried out via DIP1, DIP2, P2, P3, and P1 must be activated with DIP1/1. The settings are accepted again at every mains connection. Thus, changes on parameters made in the meantime may be overwritten.

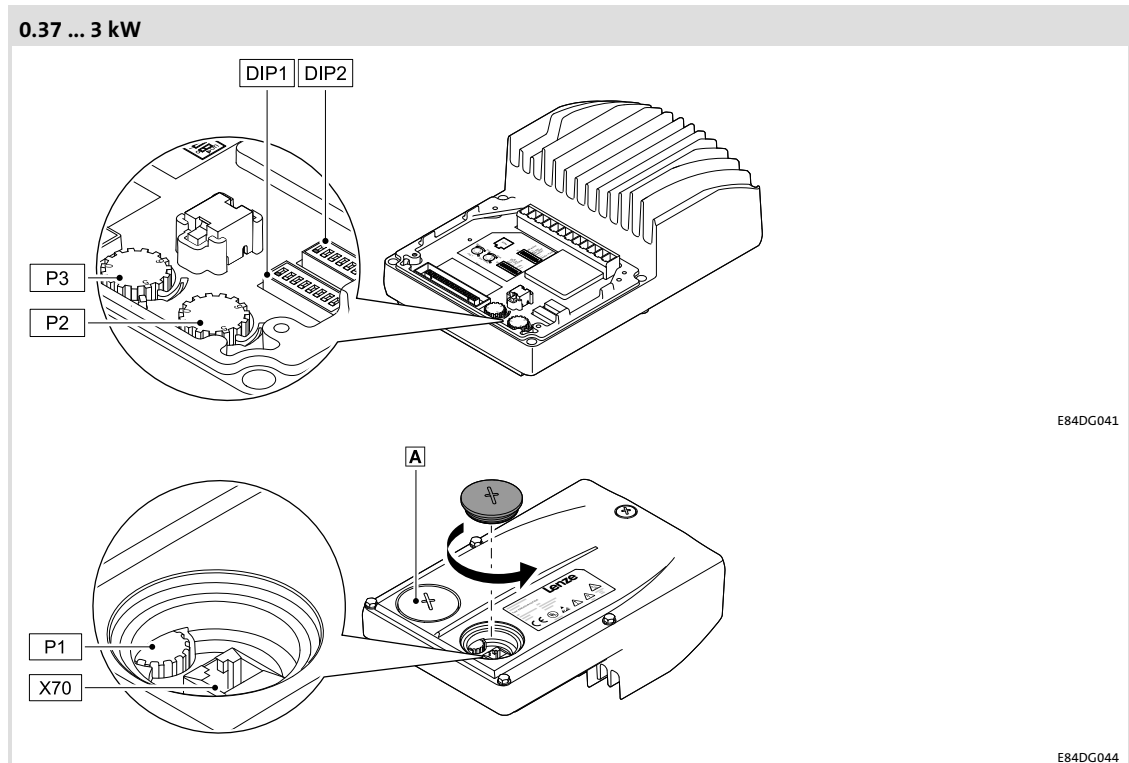

	Name
DIP1	DIP switch for commissioning
DIP2	DIP switch for commissioning
P1	Setting "Top Cover: Speed ... %"
P2	Setting "Speed ... %", (speed)
P3	Setting "Ramp ... s", (acceleration/deceleration time)
X70	Connection for E94AZCUS USB diagnostic adapter or diagnosis terminal
A	LED status display

### Setting elements 4 ... 7.5 kW

The setting elements are located on the top of the drive unit.

- ▶ Provide for isolation from supply and secure to prevent a restart.
- ▶ Remove small cover on the top.

Settings carried out via DIP1, DIP2, P2, P3, and P1 must be activated with DIP1/1. The settings are accepted again at every mains connection. Thus, changes on parameters made in the meantime may be overwritten.

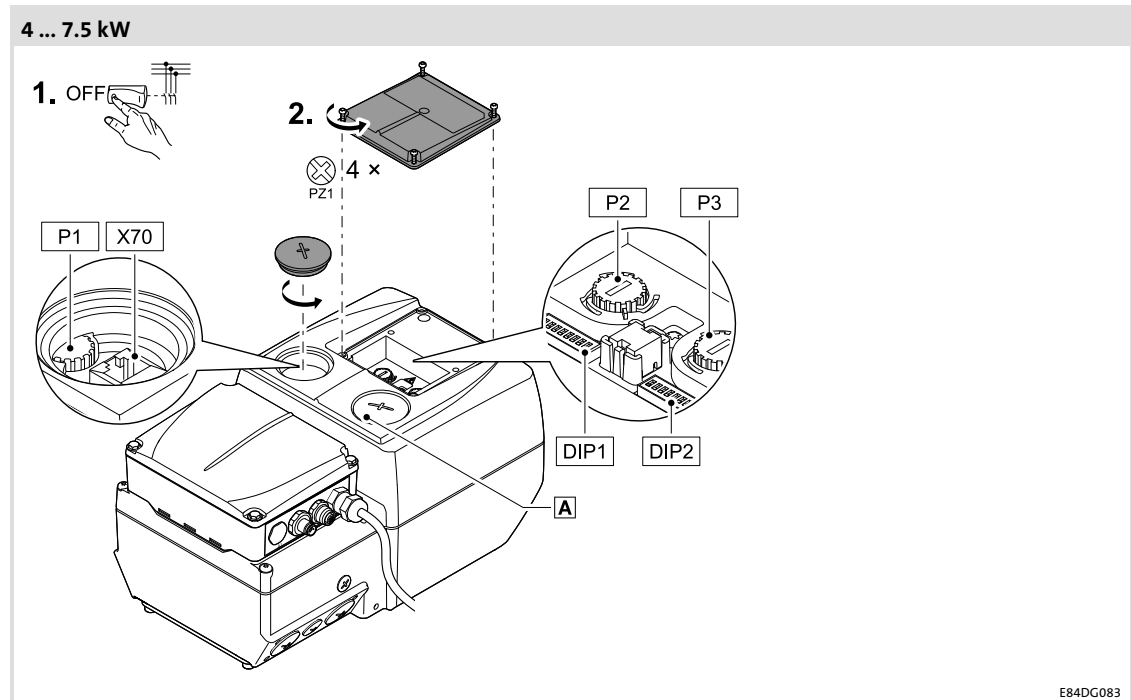

	Name
DIP1	DIP switch for commissioning
DIP2	
P1	Setting "Top Cover: Speed ... %"
P2	Setting "Speed ... %", (speed)
P3	Setting "Ramp ... s", (acceleration/deceleration time)
X70	Connection for E94AZCUS USB diagnostic adapter or diagnosis terminal
A	LED status display

6.3.1 DIP switch / potentiometer assignment 0

Settings with DIP1  
(Lenze setting **bold**)

DIP1			Switch							
Description			1	2	3	4	5	6	7	8
DIP1, DIP2, P1, P2, and P3 active	Active		<b>ON</b>							
	Inactive		<b>OFF</b>							
Direction of rotation	left			<b>ON</b>						
	right			<b>OFF</b>						
Control	square-law				<b>ON</b>					
	linear				<b>OFF</b>					
Flying restart circuit	active					<b>ON</b>				
	inactive					<b>OFF</b>				
Reserved	-						<b>OFF</b>	<b>OFF</b>	<b>OFF</b>	
Device status	Drive Ready:	NO/COM = Closed								<b>ON</b>
	Drive Fail:	DO1 = HIGH								
Device status	Drive Ready:	DO1 = HIGH								<b>OFF</b>
	Drive Fail:	NO/COM = Closed								

Settings with DIP2  
(Lenze setting **bold**)

DIP2			Switch							
Description			1	2	3	4	5	6	7	8
Rated motor frequency / reference speed	50 Hz $\Upsilon$ / 1500 rpm		<b>OFF</b>	<b>OFF</b>						
	60 Hz $\Upsilon$ / 1800 rpm		<b>ON</b>	<b>OFF</b>						
	87 Hz $\Delta$ / 2610 rpm		<b>OFF</b>	<b>ON</b>						
	120 Hz $\Upsilon$ / 3600 rpm		<b>ON</b>	<b>ON</b>						
Analog input mode	0 ... 10 V				<b>OFF</b>	<b>OFF</b>				
	0 ... 20 mA				<b>ON</b>	<b>OFF</b>				
	4 ... 20 mA				<b>OFF</b>	<b>ON</b>				
	Not permissible				<b>ON</b>	<b>ON</b>				
Control mode - technology application	9 (Local mode)						<b>OFF</b>	<b>OFF</b>	<b>OFF</b>	
	10 (terminals 0)						<b>ON</b>	<b>OFF</b>	<b>OFF</b>	
	12 (terminals 2)						<b>OFF</b>	<b>ON</b>	<b>OFF</b>	
	14 (terminals 11)						<b>ON</b>	<b>ON</b>	<b>OFF</b>	
	16 (terminals 16)						<b>OFF</b>	<b>OFF</b>	<b>ON</b>	
	Reserved						<b>ON</b>	<b>OFF</b>	<b>ON</b>	
	Reserved						<b>OFF</b>	<b>ON</b>	<b>ON</b>	
40 (MCI)						<b>ON</b>	<b>ON</b>	<b>ON</b>		
Reserved	-									<b>OFF</b>

## Commissioning

### Commissioning via DIP switch/potentiometer DIP switch / potentiometer assignment 0

Control modes DIP2/5-7	Description (Dlx → High)															
9 (local mode)	<p>The technology application is controlled locally via elements on the inverter and the digital input terminals:</p> <p><b>⚠ At mains connection the motor starts up automatically if RFR is bridged or set!</b></p> <table border="1"> <tr> <td>DI1</td> <td>Setpoint of P2 (speed)</td> <td>Preset setpoint 3</td> </tr> <tr> <td>DI2</td> <td>Preset setpoint 2</td> <td></td> </tr> <tr> <td>DI3</td> <td>Activate DC injection brake</td> <td></td> </tr> <tr> <td>DI4</td> <td>Change of direction of rotation (not possible if DIP1/2 = on (set to the left))</td> <td></td> </tr> <tr> <td>DI5</td> <td>Release holding brake manually (operating mode after setting C02580)</td> <td></td> </tr> </table>	DI1	Setpoint of P2 (speed)	Preset setpoint 3	DI2	Preset setpoint 2		DI3	Activate DC injection brake		DI4	Change of direction of rotation (not possible if DIP1/2 = on (set to the left))		DI5	Release holding brake manually (operating mode after setting C02580)	
DI1	Setpoint of P2 (speed)	Preset setpoint 3														
DI2	Preset setpoint 2															
DI3	Activate DC injection brake															
DI4	Change of direction of rotation (not possible if DIP1/2 = on (set to the left))															
DI5	Release holding brake manually (operating mode after setting C02580)															
10 (terminals 0)	<p>The technology application is controlled via the digital input terminals of the inverter:</p> <table border="1"> <tr> <td>DI1</td> <td>Preset setpoint 1</td> <td>Preset setpoint 3</td> </tr> <tr> <td>DI2</td> <td>Preset setpoint 2</td> <td></td> </tr> <tr> <td>DI3</td> <td>Activate DC injection brake</td> <td></td> </tr> <tr> <td>DI4</td> <td>Change of direction of rotation</td> <td></td> </tr> <tr> <td>DI5</td> <td>Release holding brake manually (operating mode after setting C02580)</td> <td></td> </tr> </table>	DI1	Preset setpoint 1	Preset setpoint 3	DI2	Preset setpoint 2		DI3	Activate DC injection brake		DI4	Change of direction of rotation		DI5	Release holding brake manually (operating mode after setting C02580)	
DI1	Preset setpoint 1	Preset setpoint 3														
DI2	Preset setpoint 2															
DI3	Activate DC injection brake															
DI4	Change of direction of rotation															
DI5	Release holding brake manually (operating mode after setting C02580)															
12 (terminals 2)	<p>The technology application is controlled via the digital input terminals of the inverter:</p> <table border="1"> <tr> <td>DI1</td> <td>Preset setpoint 1</td> <td>Preset setpoint 3</td> </tr> <tr> <td>DI2</td> <td>Preset setpoint 2</td> <td></td> </tr> <tr> <td>DI3</td> <td>Quick stop</td> <td></td> </tr> <tr> <td>DI4</td> <td>Change of direction of rotation</td> <td></td> </tr> <tr> <td>DI5</td> <td>Release holding brake manually (operating mode after setting C02580)</td> <td></td> </tr> </table>	DI1	Preset setpoint 1	Preset setpoint 3	DI2	Preset setpoint 2		DI3	Quick stop		DI4	Change of direction of rotation		DI5	Release holding brake manually (operating mode after setting C02580)	
DI1	Preset setpoint 1	Preset setpoint 3														
DI2	Preset setpoint 2															
DI3	Quick stop															
DI4	Change of direction of rotation															
DI5	Release holding brake manually (operating mode after setting C02580)															
14 (terminals 11)	<p>The technology application is controlled via the digital input terminals of the inverter:</p> <table border="1"> <tr> <td>DI1</td> <td>Change of direction of rotation</td> <td></td> </tr> <tr> <td>DI2</td> <td>Activate DC injection brake</td> <td></td> </tr> <tr> <td>DI3</td> <td>Motor potentiometer: speed higher</td> <td></td> </tr> <tr> <td>DI4</td> <td>Motor potentiometer: speed lower</td> <td></td> </tr> <tr> <td>DI5</td> <td>Release holding brake manually (operating mode after setting C02580)</td> <td></td> </tr> </table>	DI1	Change of direction of rotation		DI2	Activate DC injection brake		DI3	Motor potentiometer: speed higher		DI4	Motor potentiometer: speed lower		DI5	Release holding brake manually (operating mode after setting C02580)	
DI1	Change of direction of rotation															
DI2	Activate DC injection brake															
DI3	Motor potentiometer: speed higher															
DI4	Motor potentiometer: speed lower															
DI5	Release holding brake manually (operating mode after setting C02580)															
16 (terminals 16)	<p>The technology application is controlled via the digital input terminals of the inverter:</p> <table border="1"> <tr> <td>DI1</td> <td>Preset setpoint 1</td> <td>Preset setpoint 3</td> </tr> <tr> <td>DI2</td> <td>Preset setpoint 2</td> <td></td> </tr> <tr> <td>DI3</td> <td>CW rotation/quick stop</td> <td></td> </tr> <tr> <td>DI4</td> <td>CCW rotation/quick stop</td> <td></td> </tr> <tr> <td>DI5</td> <td>Release holding brake manually (operating mode after setting C02580)</td> <td></td> </tr> </table>	DI1	Preset setpoint 1	Preset setpoint 3	DI2	Preset setpoint 2		DI3	CW rotation/quick stop		DI4	CCW rotation/quick stop		DI5	Release holding brake manually (operating mode after setting C02580)	
DI1	Preset setpoint 1	Preset setpoint 3														
DI2	Preset setpoint 2															
DI3	CW rotation/quick stop															
DI4	CCW rotation/quick stop															
DI5	Release holding brake manually (operating mode after setting C02580)															
40 (MCI)	<p>The technology application is controlled via fieldbus communication.</p> <p>Depending on the Communication Unit available</p>															

**Settings with P2**(Lenze setting **bold**)

With P2 you set the motor setpoint speed as a percentage of the rated speed in C00011 in 10 steps (preset speed setpoint). The preset setpoint is only activated if the DI1 input is set in "Local mode".

P2	Setting									
Description	0	1	2	3	4	5	6	7	8	9
Motor speed in percent of the rated speed setting [%] C00011	0	11	22	<b>33</b>	44	55	66	77	88	100

**Settings with P3**(Lenze setting **bold**)

Use P3 to set the acceleration and deceleration time of the motor.

P3	Setting									
Description	0	1	2	3	4	5	6	7	8	9
Acceleration and deceleration time of the motor [s] in seconds	0.1	0.5	1	2	<b>5</b>	10	20	30	60	120

**Settings with P1**(Lenze setting **bold**)

During operation you can use P1 to steplessly set the motor speed as a percentage of the rated speed in C00011 if no preset speed setpoint P2 is active via DI1.

Remove cap in order to be able to set potentiometer P1.

- Screw cap on again after the setting process, in order to ensure that the degree of protection of the inverter is provided.

P1	Setting		
Description	0	...	9
Motor speed in percent of the rated speed C00011 [%]	0	...	<b>100</b>

## 6

### Commissioning

Commissioning via DIP switch/potentiometer  
DIP switch / potentiometer assignment 1

#### 6.3.2 DIP switch / potentiometer assignment 1

(from software version 07.00.00 onwards)

##### Settings with DIP1

(Lenze setting **bold**)

DIP1		Switch							
Description		1	2	3	4	5	6	7	8
DIP1, DIP2, P1, P2, P3	Active	ON							
	Inactive	OFF							
Motor power	Motor power > inverter power		ON						
	Motor power = inverter power		OFF						
Control	VFCplus ECO			ON					
	VFCplus linear			OFF					
Brake control / restart on the fly	Brake control off, restart on the fly off				OFF	OFF			
	Brake control off, restart on the fly on				ON	OFF			
	Brake control automatically horizontally, restart on the fly off				OFF	ON			
	Brake control automatically vertically, restart on the fly off				ON	ON			
Motor mounting direction	Inverted						ON		
	Not inverted						OFF		
Function P1	Preset setpoint 3 is always written to with P1							ON	
	Preset setpoint 3 is written to once at mains connection with P1							OFF	
Load parameters after mains connection	Load parameters from memory module								ON
	Load parameters from the Lenze setting								OFF

**Settings with DIP2**(Lenze setting **bold**)

DIP2		Switch							
Description		1	2	3	4	5	6	7	8
Rated motor frequency / reference speed	50 Hz $\Upsilon$ / 1500 rpm	<b>OFF</b>	<b>OFF</b>						
	60 Hz $\Upsilon$ / 1800 rpm	ON	OFF						
	87 Hz $\Delta$ / 2610 rpm	OFF	ON						
	120 Hz $\Upsilon$ / 3600 rpm	ON	ON						
Configuration of application	Speed actuating drive (1000)			<b>OFF</b>	<b>OFF</b>				
	AC Drive Profile (1100)			ON	OFF				
	Switch-off positioning (3000)			OFF	ON				
	Reserved			ON	ON				
Control mode - technology application	9 (Local mode)					<b>OFF</b>	<b>OFF</b>	<b>OFF</b>	
	10 (terminals 0)					ON	OFF	OFF	
	12 (terminals 2)					OFF	ON	OFF	
	14 (terminals 11)					ON	ON	OFF	
	16 (terminals 16)					OFF	OFF	ON	
	Reserved					ON	OFF	ON	
	41 (AS-Interface)					OFF	ON	ON	
	40 (MCI/CAN)					ON	ON	ON	
Selection of DIP switch / potentiometer assignment	DIP switch / potentiometer assignment 0								<b>OFF</b>
	DIP switch / potentiometer assignment 1								ON

## Commissioning

### Commissioning via DIP switch/potentiometer DIP switch / potentiometer assignment 1

Control modes DIP2/5-7	Description (Dlx → High)															
9 (local mode)	<p>The technology application is controlled locally via elements on the inverter and the digital input terminals:</p> <p><b>⚠ At mains connection the motor starts up automatically if RFR is bridged or set!</b></p> <table border="1"> <tr> <td>DI1</td> <td>Setpoint of P2 (speed)</td> <td>Preset setpoint 3</td> </tr> <tr> <td>DI2</td> <td>Preset setpoint 2</td> <td></td> </tr> <tr> <td>DI3</td> <td>Activate DC injection brake</td> <td></td> </tr> <tr> <td>DI4</td> <td>Change of direction of rotation (not possible if DIP1/2 = on (set to the left))</td> <td></td> </tr> <tr> <td>DI5</td> <td>Release holding brake manually (operating mode after setting C02580)</td> <td></td> </tr> </table>	DI1	Setpoint of P2 (speed)	Preset setpoint 3	DI2	Preset setpoint 2		DI3	Activate DC injection brake		DI4	Change of direction of rotation (not possible if DIP1/2 = on (set to the left))		DI5	Release holding brake manually (operating mode after setting C02580)	
DI1	Setpoint of P2 (speed)	Preset setpoint 3														
DI2	Preset setpoint 2															
DI3	Activate DC injection brake															
DI4	Change of direction of rotation (not possible if DIP1/2 = on (set to the left))															
DI5	Release holding brake manually (operating mode after setting C02580)															
10 (terminals 0)	<p>The technology application is controlled via the digital input terminals of the inverter:</p> <table border="1"> <tr> <td>DI1</td> <td>Preset setpoint 1</td> <td>Preset setpoint 3</td> </tr> <tr> <td>DI2</td> <td>Preset setpoint 2</td> <td></td> </tr> <tr> <td>DI3</td> <td>Activate DC injection brake</td> <td></td> </tr> <tr> <td>DI4</td> <td>Change of direction of rotation</td> <td></td> </tr> <tr> <td>DI5</td> <td>Release holding brake manually (operating mode after setting C02580)</td> <td></td> </tr> </table>	DI1	Preset setpoint 1	Preset setpoint 3	DI2	Preset setpoint 2		DI3	Activate DC injection brake		DI4	Change of direction of rotation		DI5	Release holding brake manually (operating mode after setting C02580)	
DI1	Preset setpoint 1	Preset setpoint 3														
DI2	Preset setpoint 2															
DI3	Activate DC injection brake															
DI4	Change of direction of rotation															
DI5	Release holding brake manually (operating mode after setting C02580)															
12 (terminals 2)	<p>The technology application is controlled via the digital input terminals of the inverter:</p> <table border="1"> <tr> <td>DI1</td> <td>Preset setpoint 1</td> <td>Preset setpoint 3</td> </tr> <tr> <td>DI2</td> <td>Preset setpoint 2</td> <td></td> </tr> <tr> <td>DI3</td> <td>Quick stop</td> <td></td> </tr> <tr> <td>DI4</td> <td>Change of direction of rotation</td> <td></td> </tr> <tr> <td>DI5</td> <td>Release holding brake manually (operating mode after setting C02580)</td> <td></td> </tr> </table>	DI1	Preset setpoint 1	Preset setpoint 3	DI2	Preset setpoint 2		DI3	Quick stop		DI4	Change of direction of rotation		DI5	Release holding brake manually (operating mode after setting C02580)	
DI1	Preset setpoint 1	Preset setpoint 3														
DI2	Preset setpoint 2															
DI3	Quick stop															
DI4	Change of direction of rotation															
DI5	Release holding brake manually (operating mode after setting C02580)															
14 (terminals 11)	<p>The technology application is controlled via the digital input terminals of the inverter:</p> <table border="1"> <tr> <td>DI1</td> <td>Change of direction of rotation</td> <td></td> </tr> <tr> <td>DI2</td> <td>Activate DC injection brake</td> <td></td> </tr> <tr> <td>DI3</td> <td>Motor potentiometer: speed higher</td> <td></td> </tr> <tr> <td>DI4</td> <td>Motor potentiometer: speed lower</td> <td></td> </tr> <tr> <td>DI5</td> <td>Release holding brake manually (operating mode after setting C02580)</td> <td></td> </tr> </table>	DI1	Change of direction of rotation		DI2	Activate DC injection brake		DI3	Motor potentiometer: speed higher		DI4	Motor potentiometer: speed lower		DI5	Release holding brake manually (operating mode after setting C02580)	
DI1	Change of direction of rotation															
DI2	Activate DC injection brake															
DI3	Motor potentiometer: speed higher															
DI4	Motor potentiometer: speed lower															
DI5	Release holding brake manually (operating mode after setting C02580)															
16 (terminals 16)	<p>The technology application is controlled via the digital input terminals of the inverter:</p> <table border="1"> <tr> <td>DI1</td> <td>Preset setpoint 1</td> <td>Preset setpoint 3</td> </tr> <tr> <td>DI2</td> <td>Preset setpoint 2</td> <td></td> </tr> <tr> <td>DI3</td> <td>CW rotation/quick stop</td> <td></td> </tr> <tr> <td>DI4</td> <td>CCW rotation/quick stop</td> <td></td> </tr> <tr> <td>DI5</td> <td>Release holding brake manually (operating mode after setting C02580)</td> <td></td> </tr> </table>	DI1	Preset setpoint 1	Preset setpoint 3	DI2	Preset setpoint 2		DI3	CW rotation/quick stop		DI4	CCW rotation/quick stop		DI5	Release holding brake manually (operating mode after setting C02580)	
DI1	Preset setpoint 1	Preset setpoint 3														
DI2	Preset setpoint 2															
DI3	CW rotation/quick stop															
DI4	CCW rotation/quick stop															
DI5	Release holding brake manually (operating mode after setting C02580)															
40 (MCI)	<p>The technology application is controlled via fieldbus communication.</p> <p>Depending on the Communication Unit available</p>															

**Settings with P2**(Lenze setting **bold**)

Use P2 to write different preset setpoints to C00039/1 and C00039/2.

P2 Description		Setting									
		0	1	2	3	4	5	6	7	8	9
Write preset setpoint 1 to C00039/1	[%]	5	10	15	<b>20</b>	25	30	35	40	45	50
Write preset setpoint 2 to C00039/2	[%]	10	20	30	<b>40</b>	50	60	70	80	90	100

**Settings with P3**(Lenze setting **bold**)

Use P3 to write different acceleration/deceleration times to C00012/C00013 including different deceleration times for quick stop to C00105.

P3 Description		Setting									
		0	1	2	3	4	5	6	7	8	9
Write acceleration/deceleration time to C00012/C00013	[s]	0.1	0.5	0.7	1	<b>1.5</b>	2	5	10	30	60
Write deceleration time for quick stop to C00105	[s]	0.1	0.2	0.5	0.7	<b>1</b>	1.5	2	5	10	30

**Settings with P1**(Lenze setting **bold**)

Use P1 to write a preset speed setpoint to C00039/3. Depending on the switch position of DIP1/7, C00039/3 is written to once or permanently at mains connection.

Remove cap in order to be able to set the P1 potentiometer.

- Screw cap on again after the setting process, in order to ensure the degree of protection of the inverter.

P1 Description		Setting		
		0	...	9
Write preset setpoint 3 to C00039/3	[%]	0	...	<b>100</b>

**6.3.3 Before switching on**

- ▶ The wiring unit is mounted and wired as described in the instructions,
  - directly on a motor clamping flange or
  - with the wall adapter on a suitable surface near the motor.
- ▶ Connections with the mains, motor, holding brakes, etc. have been established.
- ▶ The communication unit has been mounted and wired according to the scheduled application.
  - Input and output signals
  - Safe input
  - Fieldbus  
(depending on the version, only optionally available)
- ▶ If required, the basic settings for "local mode" have been carried out.
  - DIP switch
  - Potentiometer
- ▶ The drive unit has been mounted and screwed together.
- ▶ Use available control functions reasonably, e.g.
  - Inhibit controller enable
  - Set speed adjustment to the minimum setting
  - Activate safety system
- ▶ The use of a brake resistor has been checked.
  - In the case of dynamic loads or difficult control conditions, the use of the internal E84DZEW47R0001 brake resistor is always recommended for devices E84DGDVB4024 ... 7524 (4 ... 7.5 kW).

**Danger!****Great hazard potential during commissioning**

Incorrect settings may cause unexpected and dangerous motor and system movements.

**Possible consequences:**

- ▶ Damage to material assets
- ▶ Injury to persons

**Protective measures:**

- ▶ Clear hazardous area
- ▶ Observe safety instructions and safety clearances

### 6.3.4 Commissioning steps

Proceed step by step:

- ▶ Switch on the mains
- ▶ Monitor status display
  - After a short initialisation time, the display must be blinking green.
- ▶ Deactivate requirements of the safety function
- ▶ Set controller enable
  - After the set starting time, the motor must rotate with the speed set.
- ▶ Initial check of the expected behaviour:
  - Direction of rotation?
  - Starting time?
  - Speed?
  - Speed control?
- ▶ Check of optional control functions:
  - Is the analog setpoint selection working?
  - Are the digital control signals, e.g. limit switches, working?
  - Is the connected motor holding brake working?
  - Is the function for changing over the rotating direction working?
  - Is the requirement with regard to the safety function working?
  - Are the control signals via fieldbus working?
- ▶ Switch off drive
  - Reduce speed
  - Inhibit controller enable
  - Switch off mains



#### Note!

##### Save parameter settings safe against mains failure

In order to prevent parameter settings carried out in the device from being lost by mains switching, you have to explicitly save the parameter set with mains failure protection in the device.

**6.4 Commissioning via the diagnosis terminal**

The X400 diagnosis terminal serves to quickly and easily set parameters and display current actual values and device states by means of the corresponding display parameters. For this purpose, the diagnosis terminal must be plugged onto the X70 diagnostic interface on the top of the device.

**Danger!****Uncontrolled motor movement possible**

In general, changing a parameter causes an immediate response in the inverter.

**Possible consequences:**

- ▶ This may lead to undesirable behaviour on the motor shaft if the inverter has been enabled.

**Protective measures:**

- ▶ Make changes in small steps and wait for response.
- ▶ Certain device commands or settings which may cause critical states of drive behaviour constitute exceptions. Such parameter changes are only possible if the inverter is inhibited. Otherwise, a corresponding error message will be issued.

**Note!**

Plugging and unplugging the diagnosis terminal during operation is permissible.

**More information ....**

Detailed information regarding the diagnosis terminal can be found in the operating instructions for the X400 keypad & diagnosis terminal.

6.4.1 Display elements and function keys

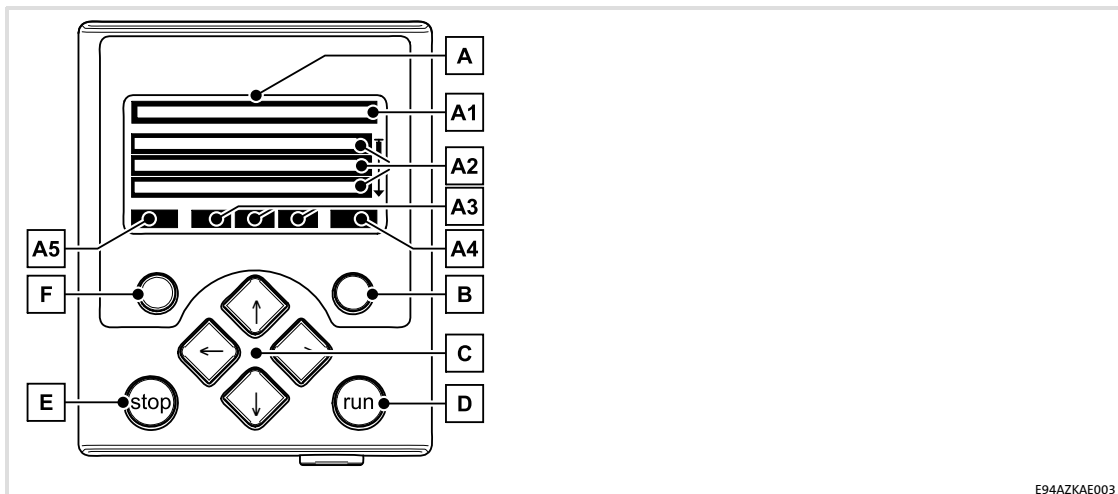

E94AZKAE003

Display	Meaning	Comment
<b>A</b>	<b>LCD display</b>	
<b>A 1</b>	<b>Headline</b>	
	<MM M>	Meaning of the menu In the menu level only
	<PPP>	Meaning of the parameter In the parameter level only
<b>A 2</b>	<b>Triple-spaced display</b>	
	<M1> <M2> <...>	List of the menus available In the menu level only
	<P1> <P2> <...>	List of the parameters available In the parameter level only
	<xxx>	Setting of the selected parameter
<b>A 3</b>	<b>Status of the basic device</b>	
	<b>RDY</b>	The basic device is ready for operation.
	<b>RUN</b>	The basic device is enabled.
	<b>□</b>	Application in the basic device is stopped.
	<b>QSP</b>	Quick stop active
	<b>CINH</b>	The basic device is inhibited. The power outputs are inhibited.
	<b>OFF</b>	The basic device is ready to start.
	<b>Mmax</b>	Speed controller 1 in the limitation The drive is torque-controlled.
	<b>I<sub>max</sub></b>	Set current limit exceeded in motor or generator mode
	<b>IMP</b>	Pulse inhibit active The power outputs are inhibited.
	<b>ISFLT</b>	System error active
	<b>IFLT</b>	Error active
	<b>ITRB</b>	Fault active
	<b>ITosp</b>	Quick stop by trouble active
	<b>WRN</b>	Warning active

## Commissioning

Commissioning via the diagnosis terminal  
Menu structure

Display	Meaning	Comment	
A 4	Current function of the right function key		
	<b>OK</b>	Confirm and accept changes	
	<b>HELP</b>	Call up help	Is only displayed if a detailed help is available.
	<b>NEXT</b>	Browse to the next page.	
A 5	Current function of the left function key		
	<b>←</b>	Back to the main menu	
	<b>SAVE</b>	Save parameter set in the drive non-volatily.	
	<b>EDIT</b>	Alter parameter	
	<b>ESC</b>	Cancel action without accepting the change.	
	<b>PREV</b>	Browse to the previous page.	
	<b>PGOII</b>	Parameter can only be altered if the application of the basic device is stopped.	
	<b>GINHII</b>	Parameter can only be altered if the basic device is inhibited.	

Key	Function	Comment	
<b>B</b>	□	Carry out the function indicated in the field A4.	
<b>D</b>	⊞	Deactivate the function of the ⊞ key. The LED in the ⊞ key goes out.	
<b>E</b>	⊞	Carry out the function selected in C00469 in the "Keypad" menu. The LED in the key is on.	Lenze setting: activate quick stop.
<b>F</b>	□	Carry out the function indicated in the field A5.	

Key	Function				
	Menu level		Parameter level		
	Main menu	Submenu	Overview (9400)	Detail	Editing mode
⊞	⊞	Select menu	Select submenu	Select parameter	Alter selected digit
	↔	To the submenu	To the parameter level	To the detail view	Cursor to the right
	↔		Back to the main menu	Back to the menu level	Back to the overview Cursor to the left

### 6.4.2 Menu structure

The main menu of the diagnosis terminal contains the following entries:

Menu item	Function
User menu	Display of a selection of frequently required parameters
Code list	Display of the parameter list with all parameters
Go to parameter	Directly calls a certain parameter
Parameter transfer	
User menu configuration	
Keypad	

### 6.4.3 User menu

The user menu can be freely configured in C00517 and contains the following parameters in the Lenze setting:

Parameters	Name	Info	Lenze setting
C00011	Appl.: Reference speed	Setting the reference speed	1500 rpm
C00012	Accel. time - main setpoint	FB L_NSet_1: Acceleration time of the ramp generator for the main speed setpoint	2.0 s
C00013	Decel. time - main setpoint	FB L_NSet_1: Deceleration time of the ramp generator for the main speed setpoint	2.0 s
C00015	VFC: V/f base frequency	V/f base frequency for VFCplus motor control	50 Hz
C00016	VFC: Vmin boost	Boost of the V/f voltage characteristic within the range of low speed or frequency values for the VFCplus motor control.	2.6 %
C00022	I <sub>max</sub> in motor mode	Maximum current in motor mode for all motor control modes	5.8 A
C00039/1	Preset setpoint 1 (L_NSet_1 n-Fix)	FB L_NSet_1: Fixed speed setpoints (JOG values) for the setpoint generator Fixed setpoint 1	40.0 %
C00039/2	Fixed setpoint 2	Fixed setpoint 2	60.0 %
C00051	MCTRL: Actual speed value	Actual speed value of the motor shaft	–
C00053	DC-bus voltage	Actual DC-bus voltage	–
C00054	Motor current	Current motor current/output current of the inverter	–
C00061	Heatsink temperature	Current heatsink temperature	–
C00087	Rated motor speed	This value can be obtained from the motor nameplate. After the motor to be used has been selected from the motor catalogue, the suitable value can be entered automatically.	1320 rpm
C00099	Firmware version	Firmware version of the device as string	–
C00105	Decel. time - quick stop	The set deceleration time determines the ramp slope at quick stop	5.0 s
C00120	Motor overload threshold (I <sup>2</sup> xt)	Operating threshold for the error message "OC6: Motor overload (I <sup>2</sup> xt)"	100 %
C00137	Device status	Current device state	–
C00166/3	Mess. - status det. error	Textual message of the currently pending error	–
C00173	Mains voltage	Selection of the mains voltage for operating the device.	0: "3ph 400V"
C00200	Firmware product type		–

– Read only

**6.4.4 Commissioning steps****Note!**

The following can be connected to the X70 diagnostic interface:

- ▶ USB diagnostic adapter (E94AZCUS)
- ▶ X400 diagnosis terminal (EZAEBK200x)
  - The functions of the X400 diagnosis terminal and keypad (EZAEBK100x) are identical.

Only some parameters must be adapted for the drive. Then the drive application can be controlled immediately in the preset "Terminals 0" control mode via the digital and analog inputs. Alternatively, the keypad can be used for defining the required setpoints and control signals in the "Keypad" control mode.

How to proceed:

1. Wiring of power terminals
  - Make use of the mounting instructions supplied with the inverter to wire the power terminals according to the requirements of your device.
2. Wiring of control terminals.
  - The preconfigured I/O connection can be changed via configuration parameters. See chapter "User-defined terminal assignment".
  - Assignment in the preset "Terminals 0" control mode:

Terminal	Function	Info
A1U	Setpoint selection	10 V ≙ 1500 rpm (with 4-pole motor) general: 10 V ≙ 100 % reference speed (C00011)
DI1	JOG 1	Selection of preset setpoints 1 ... 3 ● If both inputs are on LOW level, the setpoint selection via the analog input A1U is active.
DI2	JOG 2	
DI3	DCB	Manual DC-injection braking (DCB) ● For HIGH-active inputs, DC-injection braking is active as long as DI3 is at HIGH level. ● After the hold time (C00107) has expired, the inverter sets pulse inhibit (CINH). DC-injection braking (▶Ĥ 110)
DI4	R/L	LOW level: CW rotation HIGH level: CCW rotation
DI5	Holding brake	Open/close holding brake ● Braking modes C02580

3. Check switch at the bottom of the drive unit:  
DIP1/1 must be "OFF" (Lenze setting) in order that the parameters can be overwritten via »Engineer«, keypad, or fieldbus.
4. If required, carry out communication settings via the DIP switch on the Communication Unit for fieldbus communication.  
The communication settings depend on the fieldbus used.
5. Fasten the controller by means of the 4 screws.
6. Switch on voltage supply of the inverter.
7. Connect keypad.
  - Remove the cover of the diagnostic interface on the top of the device and connect the keypad to the diagnostic interface.
  - When the keypad has been connected, the connection to the inverter is established. This process is completed when C00051 is shown in the display.

Keypad display	Action
MCTRL: Act speed val. C00051 0 rpm	Use left function key  to change to main menu.

8. Load Lenze setting to inverter.
  - For this purpose, the device command "Load Lenze setting" is available which can be executed via code C00002/1 with the keypad:





**Note!**

With the "Load Lenze settings" command, values that have been changed previously are overwritten. Default settings for a specific motor, e.g. by Lenze for motor mounting with geared motor, are reset.

## Commissioning

Commissioning via the diagnosis terminal

Commissioning steps

Keypad display	Action
<b>Par1 8400 motec</b> User menu	A Select the menu in the main menu using the  navigation key. B Change to the menu using the  navigation key.
<b>Load Lenze setting</b> C00002/1	A Use the left function key <b>EDIT</b> to change to the editing mode for C00002/1. B Use navigation key  to select the "1: On/Start" entry in the selection list. C Use the right function key <b>OK</b> to accept the executed change and quit the editing mode. – The load process may take a couple of seconds.

### 9. Enable inverter: Set RFR to HIGH potential.

- By default, the RFR terminal is bridged (controller enable).
- If the auto-start option "Inhibit at power-on" is activated in C00142 and the controller is enabled at mains connection, the controller remains in the "ReadyToSwitchOn" status. For changing to the "SwitchedOn" status, controller enable must first be deactivated. Only when the controller is enabled again afterwards, the status changes to "OperationEnabled":
- If the autostart option "Inhibit at power-on" is deactivated in C00142, the status directly changes from "ReadyToSwitchOn" to the "SwitchedOn" state and to the "OperationEnabled" state after mains connection when the controller is enabled.



### Danger!

When the auto-start option "Inhibit at power-on" is deactivated, the motor can directly start after power-on if the controller is enabled!

### 10. Select speed:

- In the "Terminals 0" by selecting a voltage at the analog input or by selecting a fixed setpoint via the digital inputs DI1/DI2.
- In the "Keypad" control mode, the main speed setpoint and the control signals are predefined via the following parameters:

Parameters	Name	Info	Lenze setting
C00728/3	nMainSetValue_a	Main setpoint for the application 100 % ≙ reference speed (C00011)	0.00 %
C00727/3	bSetSpeedCcw	Change of direction of rotation "0": CW rotation "1": CCW rotation	0
C00727/4	bJogSpeed1	Selection of fixed setpoint 1 "0": Main setpoint (C00728/3) active. "1": Fixed setpoint 1 (C00039/1) active.	0

### 11. If required, adapt further parameters.

### 12. Save parameter settings with function key **SAVE** safe against mains failure in the memory module.

## 6.4.5 SET mode

In SET mode, the inverter is controlled via the diagnosis terminal. You can change the speed setpoint and enable or inhibit the inverter (RFR/run). Other setpoint sources are ignored.

- ▶ Activate SET mode: press "DISP" softkey button and confirm with "OK" softkey button.
- ▶ Exit SET mode: press "DISP" softkey button and confirm with "OK" softkey button.

**Note!**





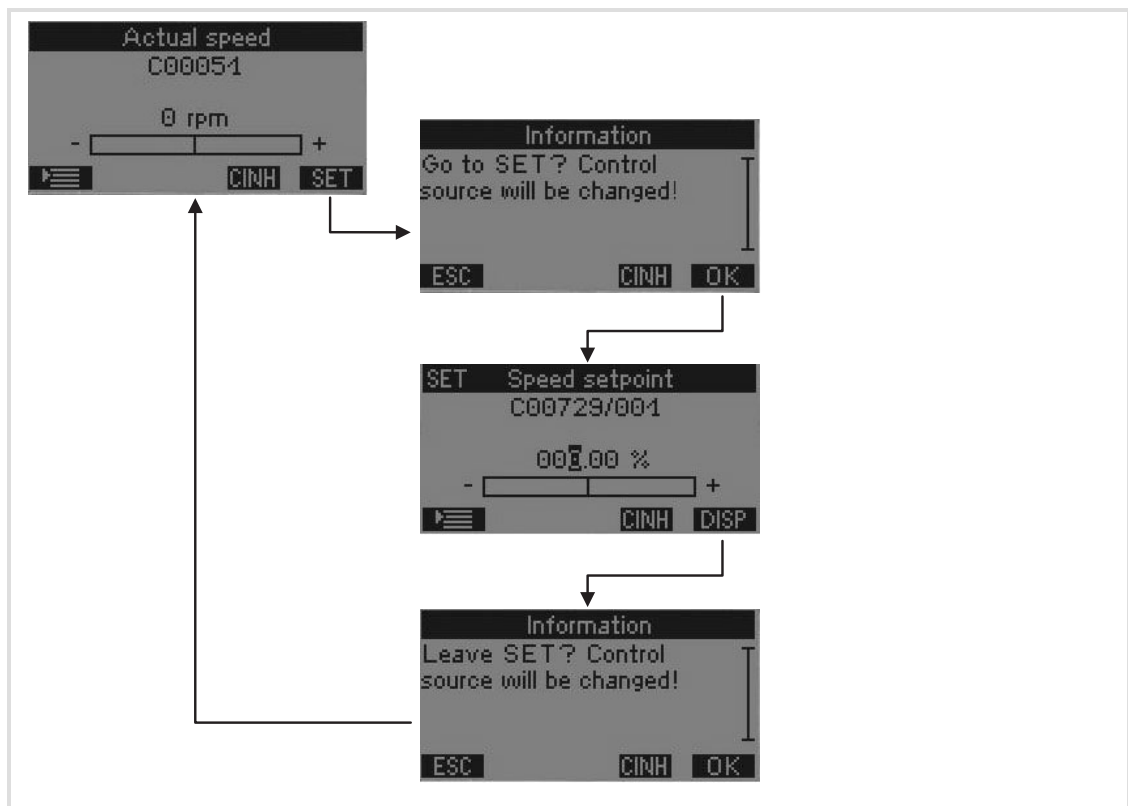





SET mode can only be activated in the "OperationEnabled" device state (controller inhibit is deactivated, green LED on the inverter is lit permanently).

- ▶ Controller inhibit is only indicated in the keypad. The cause of controller inhibit is shown in detail in C00158 ([8400 motec reference manual](#)).







### 6.5 Diagnostics

On the top side of the Drive Unit, a two-coloured LED display indicates the respective operating status of the inverter. The LED shines through the transparent cap.

green "DRIVE READY"	red "DRIVE ERROR"	Description	Device status (Display in C00137)
OFF	OFF	OFF or initialisation active	Init
	OFF	Safe torque off is active	SafeTorqueOff
	OFF	Device is ready to start	ReadyToSwitchON
	OFF	Device is switched on	SwitchedOn
	OFF	Motor data identification/operation	OperationEnabled
  		The inverter is ready to switch on, switched on, or operation is enabled and a warning is pending	
OFF		Trouble active	Trouble
OFF		Error active	Fault

#### Legend

Meaning of the symbols used

	LED flashes once approx. every 3 seconds (slow flash)
	LED flashes once approx. every 1.25 seconds (flash)
	LED flashes twice approx. every 1.25 seconds (double flash)
	LED is blinking every second
	LED is permanently on

## 7 Braking operation

### 7.1 Braking operation without additional measures

#### DC injection brake DCB

To decelerate small masses, the "DC injection brake DCB" function can be parameterised. DC-injection braking enables a quick deceleration of the drive to standstill without the need for an external brake resistor.

- ▶ Code C00036 can be used to select the braking current.
- ▶ The maximum braking torque to be realised by the DC braking current amounts to approx. 20 ... 30 % of the rated motor torque. It is lower compared to braking action in generator mode with external brake resistor.
- ▶ Automatic DC-injection braking (Auto-DCB) improves the starting performance of the motor when the operation mode without speed feedback is used.

Further information on the relevant parameters can be obtained from the software manual.

## 7.2 Braking operation with brake resistor

To decelerate greater moments of inertia or with a longer operation in generator mode, a brake resistor is required. It converts braking energy into heat.

The brake resistor is connected if the DC-bus voltage exceeds the switching threshold. This prevents the controller from setting pulse inhibit through the "Overvoltage" fault and the drive from coasting. The brake resistor serves to control the braking process at any time.

Options with 8400 motec:

1. There is no internal brake resistor integrated in the device. Braking energy cannot be converted into heat.
2. An internal brake resistor can optionally be attached from the corresponding accessories. This enables the conversion of small amounts of braking energy into heat, according to the technical data.
3. An external brake resistor can optionally be attached from the accessories (📖 195). This enables the conversion of braking energy into heat, according to the technical data.

## 7.2.1 Selection of the brake resistors

The recommended Lenze brake resistors are adapted to the corresponding controller (with regard to 150 % of regenerative power). They are suitable for most of the applications.

For special applications, e.g. centrifuges, the brake resistor must meet the following criteria:

Brake resistor Criterion	Application	
	With active load	With passive load
Continuous braking power [W]	$\geq P_{\max} \cdot \eta_e \cdot \eta_m \cdot \frac{t_1}{t_{\text{zykl}}}$	$\geq \frac{P_{\max} \cdot \eta_e \cdot \eta_m}{2} \cdot \frac{t_1}{t_{\text{zykl}}}$
Heat quantity [Ws]	$\geq P_{\max} \cdot \eta_e \cdot \eta_m \cdot t_1$	$\geq \frac{P_{\max} \cdot \eta_e \cdot \eta_m}{2} \cdot t_1$
Resistance [ $\Omega$ ]	$R_{\min} \leq R \leq \frac{U_{\text{DC}}^2}{P_{\max} \cdot \eta_e \cdot \eta_m}$	

Active load Can start to move independent of the drive (e.g. unwinder)

Passive load Can stop independent of the drive (e.g. horizontal travelling drives, centrifuges, fans)

$V_{\text{DC}}$  [V] Switching threshold of brake chopper (8400 motec = 783 V)

$P_{\max}$  [W] Maximum occurring braking power determined by the application

$\eta_e$  Electrical efficiency (controller + motor)  
Guide value: 0.54 (0.25 kW) ... 0.85 (11 kW)

$\eta_m$  Mechanical efficiency (gearbox, machine)

$t_1$  [s] Braking time

$t_{\text{cycl}}$  [s] Cycle time = time between two successive braking processes (=  $t_1$  + dead time)

$R_{\min}$  [ $\Omega$ ] Minimum permissible brake resistance (see rated data of the integrated brake chopper)

## 7.2.2 Wiring of brake resistor

**Danger!****Hazardous electrical voltage**

During operation of the standard device and **up to 3 minutes after power-off** hazardous electrical voltages may occur at the terminals of the brake resistor.

**Possible consequences:**

- ▶ Death or severe injuries when touching the terminals.

**Protective measures:**

- ▶ Disconnect the standard device from the mains before working on the brake resistor.
- ▶ Check all power terminals for isolation from supply.
- ▶ Select the mounting location so that the operating conditions mentioned in the mounting instructions for the brake resistor are permanently guaranteed.

**Danger!****Hot surface**

The brake resistor may get very hot. (For temperatures see the mounting instructions for the brake resistor.)

**Possible consequences:**

- ▶ Severe burns when touching the brake resistor.
- ▶ Fire or smouldering fire if flammable material is placed near the brake resistor or may get to it.

**Protective measures:**

- ▶ Before working on the brake resistor, check its surface temperature.
- ▶ Select the mounting location so that the operating conditions mentioned in the mounting instructions for the brake resistor are permanently guaranteed.
- ▶ Protect the mounting location through fire prevention.

Protect the brake resistor and controller against destruction caused by overload:

- ▶ Establish an external safety shutdown using the thermostat of the brake resistor to disconnect the controller from the mains.
- ▶ Exception for devices with special connection for the thermostat of the brake resistor: Use the device-internal safety shutdown.

Connecting cable version

- ▶ up to 0.5 m: twisted and unshielded
- ▶ from 0.5 to 5 m: shielded
  - Use shielded cables to meet the EMC requirements.

## Braking operation

### Braking operation with brake resistor Wiring of brake resistor

#### Wiring principle

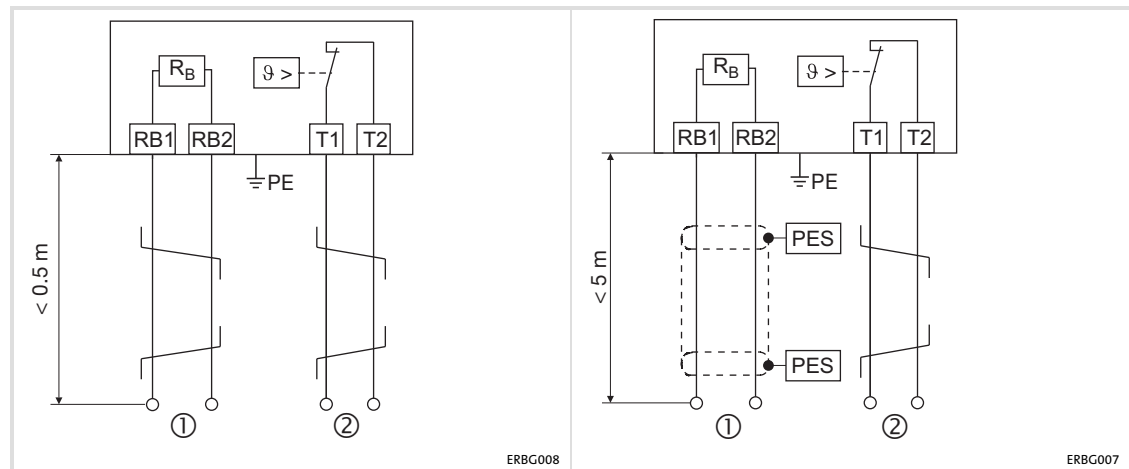

Fig. 7-1 Wiring of a brake resistor to the controller

PES	HF-shield termination by PE connection via shield clamp
Rb1, Rb2	Terminals of the brake resistor
①	Supply cable to the controller
T1, T2	Terminals temperature monitoring of the brake resistor (thermal contact/NC contact)
②	Supply cable for evaluation of temperature monitoring (to be integrated e.g. into the latch circuit of the mains contactor of the supply)

The brake resistor is thermally stressed due to converted braking power and may be thermally destroyed as a consequence of excessive braking power.

To avoid thermal overload of the brake resistor:

- ▶ set additional parameters in the »Engineer«
- or
- ▶ implement external wiring using a temperature contact on the brake resistor (e.g. interrupted supply and activation of the mechanical brakes).

To protect the brake resistor:

- ▶ use the monitoring of the  $I^2xt$  utilisation of the controller which is proportional to the converted braking power.

## Evaluation of the thermal contact via digital input

The integration of the thermal contact for monitoring the brake resistor can be implemented via digital input. Use a Lenze system cable. The response to the input signal must be parameterised using the »Engineer«.

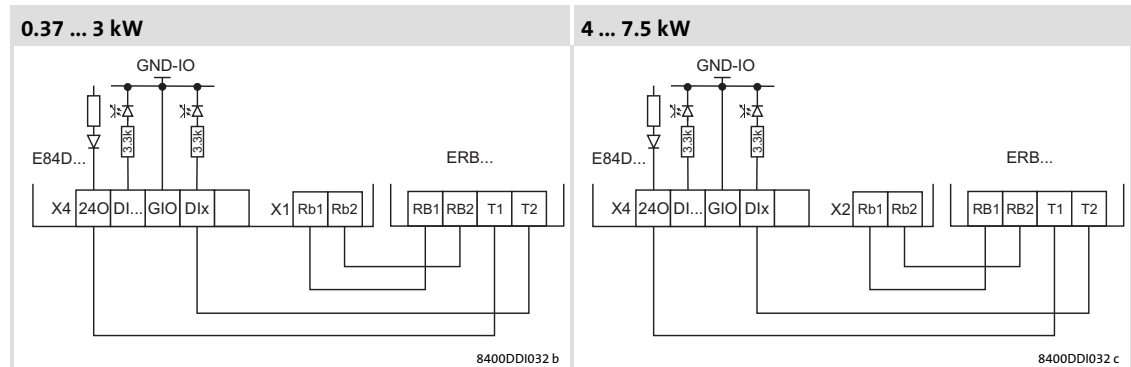

E84D...  
X4/DIx  
X1/Rb1,Rb2  
X2/Rb1,Rb2  
ERB...

8400 motec  
free digital input  
Connection of the brake resistor for devices 0.37 ... 3 kW  
Connection of the brake resistor for devices 4 ... 7.5 kW  
Brake resistor

## 7

### Braking operation

Operation with spring-applied brake  
Introduction

#### 7.3 Operation with spring-applied brake

##### 7.3.1 Introduction

Lenze three-phase AC motors and G-motion geared motors can be equipped with spring-applied brakes (motor holding brakes). 8400 motec controllers are provided with an integrated motor brake control.

##### Switching the brake

The voltage required for controlling the motor brake is generated in the controller, depending on the mains voltage value. The following motor brakes can be connected:

- ▶ With 400-V mains: Coil voltage 180 V DC
- ▶ With 480-V mains: Coil voltage 215 V DC

Optionally, the switching of the brake can be controlled in addition:

- ▶ Via an external control contact (e.g. PLC)
- ▶ Via a brake switch which is connected to one of the digital outputs of the controller. The digital output must be parameterised accordingly.

The software manual provides further information on the parameterisation and integrated brake management.

##### 7.3.2 Wiring

The cable of the motor holding brake can be routed directly by means of a cable gland in parallel to the motor axis.

The motor holding brake is connected to BD1 (+) and BD2 (-).

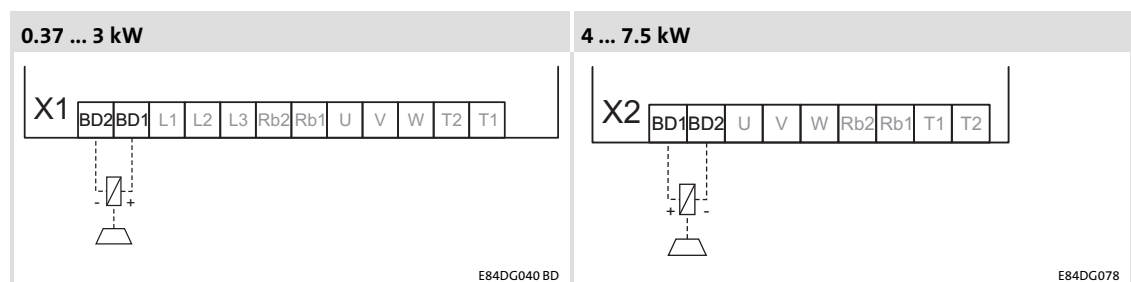

X1	Terminal in the Wiring Unit for devices 0.37 ... 3 kW
X2	Terminal in the Wiring Unit for devices 4 ... 7.5 kW
BD1	Connection of spring-applied brake +
BD2	Connection of spring-applied brake -
⚡	HF-shield termination by large surface connection to PE.
⊕	Earthing (PE)

## 8 Safety engineering

### 8.1 Introduction

With increasing automation, protection of persons against hazardous movements is becoming more important. Functional safety describes the measures needed by means of electrical or electronic equipment to reduce or remove danger caused by failures.

During normal operation, safety equipment prevents people accessing hazardous areas. In certain operating modes, e.g. set-up mode, work needs to be carried out in hazardous areas. In these situations the machine operator must be protected by integrated drive and control measures.

Drive-based safety provides the conditions in the controls and drives to optimise the safety functions. Planning and installation expenditure is reduced. In comparison to the use of standard safety engineering, drive-based safety increases machine functionality and availability.

#### **Drive-based safety with Inverter Drives 8400**

Decentralised drives are frequency inverters that are not mounted locally like control cabinet devices but are directly attached to the application in the field. This product-specific feature results in high demands regarding robustness and class of protection.

The 8400 motec controllers are optionally available with an integrated safety system.

”Integrated safety” stands for application-oriented safety functions that are applicable on machines for the protection of persons.

The motion functions continue to be executed by the controller. The integrated safety system monitors the safe compliance with the limit values and provides the safe inputs and outputs. If limit values are exceeded, the integrated safety system starts control functions according to EN 60204-1 directly in the controller for the case of an error.

The safety functions are suitable for applications according to IEC 61508 to SIL 3 and achieve the performance level (PL)e according to EN ISO 13849-1. The requirements of the standard EN 954-1 valid until 30 November 2009 are met until control category 4.

## 8.2

## Important notes

**Application as directed**

The controllers that are equipped with safety engineering must not be modified by the user. This concerns the unauthorised exchange or removal of the safety engineering.

**Danger!****Danger to life through improper installation**

Improper installation of safety engineering systems can cause an uncontrolled starting action of the drives.

**Possible consequences:**

- ▶ Death or severe injuries

**Protective measures:**

- ▶ Safety engineering systems may only be installed and commissioned by qualified and skilled personnel.
- ▶ All control components (switches, relays, PLC, ...) and the control cabinet must comply with the requirements of ISO 138491 and ISO 13849-2. This includes i.a.:
  - Switches, relays with at least IP54 enclosure.
  - Control cabinet with at least IP54 enclosure.
  - Please refer to ISO 138491 and ISO 13849-2 for all further requirements.
- ▶ Wiring must be shielded.
- ▶ All safety relevant cables outside the control cabinet must be protected, e.g. by means of a cable duct:
  - Ensure that no short circuits can occur.
  - For further measures see EN ISO 13849-2.
- ▶ If an external force acts upon the drive axes, additional brakes are required. Please observe that hanging loads are subject to the force of gravity!

**Danger!**

When the "safe torque off" (STO) function is used, an "emergency switching-off" according to EN 60204 is not possible without additional measures. There is no electrical isolation, no service switch or repair switch between motor and controller!

"Emergency switching-off" requires an electrical isolation, e.g. by a central mains contactor!

### **During operation**

After the installation is completed, the operator must check the wiring of the safety function.

The functional test must be repeated at regular intervals. The time intervals to be selected depend on the application, the entire system and the corresponding risk analysis. The inspection interval should not exceed one year.

### **Residual hazards**

In case of a short-circuit of two power transistors a residual movement of the motor of up to  $180^\circ$ /number of pole pairs may occur! (Example: 4-pole motor  $\Rightarrow$  residual movement max.  $180^\circ/2 = 90^\circ$ )

This residual movement must be considered in the risk analysis, e.g. safe torque off for main spindle drives.

## **8.2.1 Hazard and risk analysis**

This documentation can only accentuate the need for hazard analysis. The user of the integrated safety system must read up on standards and the legal situation:

Before the launch of a machine, the manufacturer of the machine must conduct a hazard analysis according to Machinery Directive 2006/42/EC to determine the hazards associated with the application of the machine. The Machinery Directive refers to three basic principles for the highest possible level of safety:

- ▶ Hazard elimination / minimisation by the construction itself.
- ▶ Required protective measures must be taken against hazards which cannot be eliminated.
- ▶ Existing residual hazards must be documented and the user must be informed of them.

Detailed information on the hazard analysis procedure is provided in the DIN EN ISO 12100:2013-08 - "Safety of machinery - General principles for design, risk assessment and risk reduction". The results of the hazard analysis determine the category for safety-related control systems according to EN ISO 13849-1. Safety-oriented parts of the machine control must be compliant.

## **8.2.2 Standards**

Safety regulations are confirmed by laws and other governmental guidelines and measures and the prevailing opinion among experts, e.g. by technical regulations.

The regulations and rules to be applied must be observed in accordance with the application.

**8.3 Basics for safety sensors****Passive sensors**

Passive sensors are two-channel switching elements with contacts. The connecting cables and the sensor function must be monitored.

The contacts must switch simultaneously (equivalently). Nevertheless, safety functions will be activated as soon as at least one channel is switched.

The switches must be wired according to the closed-circuit principle.

Examples of passive sensors:

- ▶ Door contact switch
- ▶ Emergency stop control units

**Active sensors**

Active sensors are units with 2-channel semiconductor outputs (OSSD outputs). With the integrated safety system of this device series, test pulses  $< 1$  ms for monitoring the outputs and cables are permissible. The maximally permissible connection capacity of the outputs is to be observed. Active sensors are wired directly to the terminals of the integrated safety system. Monitoring for cross or short circuits must be carried out by the active sensor.

P/M-switching sensors switch the positive and negative cable or the signal and ground wire of a sensor signal.

The outputs must switch simultaneously (equivalently). Nevertheless, safety functions will be activated as soon as at least one channel is switched. Active triggering of only one channel indicates faulty sensors or impermissible wiring.

Examples of active sensors:

- ▶ Lightgrid
- ▶ Laser scanner
- ▶ Control systems

## 8.4 Operating mode

### 8.4.1 Introduction

Due to safety option 10, the following safety functions can be used:

- ▶ Safe torque off (STO),  
formerly: safe standstill

If requested, the safe disconnection of the drive is achieved through:

- ▶ Directly connected active sensors
- ▶ Passive sensors connected to a safety switching device

The safety functions are suitable for applications according to IEC 61508 to SIL 3 and achieve a performance level (PL) e and the control category 4 according to EN ISO 13849-1.



#### Danger!

If the request for the safety function is cancelled, the drive will restart automatically.

You must provide external measures which ensure that the drive only restarts after a confirmation (EN 60204).

### 8.4.2 Disconnecting paths

The transmission of the pulse width modulation is safely switched (off) by the safety unit. After this, the power drivers do not generate a rotating field. The motor is safely switched to torqueless operation (STO).

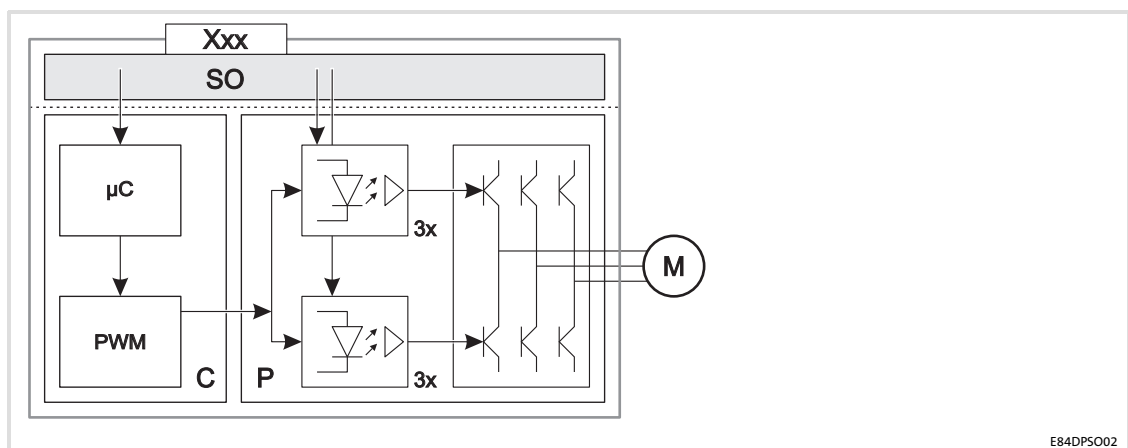

Fig. 8-1 Operating principle of safety unit

SO	Safety option 10
xxx	Control terminals of the safety system or safety bus
C	Control section
μC	Microcontroller
PWM	Pulse width modulation
P	Power section
M	Motor

## 8 Safety engineering

Operating mode  
Safety status

### 8.4.3 Safety status

When the controller is disconnected from the safety unit, the "Safe torque off" (STO) status is set (C00155 bit 10 = 1).

## 8.5 Technical data

### Supply

The safe input and the output are isolated and designed for a low-voltage supply through a safely separated power supply unit (SELV/PELV) of 24 V DC. PM-switching input signals and test pulses  $\leq 1$  ms are permissible.

Active sensors are directly connected to X61.

Passive sensors are connected to X61 via a switching device. The switching device must comply with the required performance level of the application.

There is no monitoring for short circuits.

### Detailed features of the inputs and outputs of the safety unit

Classification of binary 24 V interfaces in compliance with ZVEI (German electrical and electronics manufacturers association): interface type C, class 1

Terminal	Specification	[Unit]	Min.	Typ.	Max.
SIA, SIB	Low signal	V	-3.0	0	5.0
	High signal	V	18	24	30
	Input capacitance at switch-off	nF		3	
	Input delay (tolerated test pulse)	ms			1.0
	Switch-off time (depending on the controller)	ms	1.8	2.5	5.0
	Running time	ms		3.0	
	Input current SIA	mA		35	50
	Input current SIB	mA		25	50
	Input capacitance at switch-on	$\mu$ F		6	
	Input resistance	$\Omega$	360		
	Repetition rate of the test pulses	ms	10		
GI	GND potential for SIA / SIB and for the unsafe signalling output				
240	Supply voltage through safely separated power supply unit (SELV/PELV)	V	18	24	30
DO	Low signal	V		0	0.8
	High signal	V	18	24	30
240, DO	Output current	A			0.2

### Truth table

Safe input / channel		Signalling output	Inverter	
SIA	SIB		Description of device status	Approval
0	0	1	"SafeTorqueOff" activated (safe torque off)	0
0	1	0		0
1	0	0		0
1	1	0	Drive active or "ReadyToSwitchOn"	1

**Note!**

Safe inputs are designed with 2 channels (...A/...B). The channels must be controlled separately and simultaneously (in an equivalent manner).

The active control of only one channel indicates a faulty sensor system or an impermissible interconnection.

**Restriction of use**

The operation of an integrated safety system is **not** permissible in earthed phase mains.

8.6 Electrical installation

X61 - connection of safety system "Safety Option 10"		
Pin	Connection	Description
<p>E84DG027</p>		Terminal strip, 5-pole
	SIA	Safe input, channel A
	SIB	Safe input, channel B
	GI	GND potential for SIA/SIB GND potential for the unsafe signalling output
	24O	24 V voltage supply for the unsafe signalling output
	DO	Unsafe signalling output: "SafeTorqueOff" with a 2-channel request by SIA and SIB

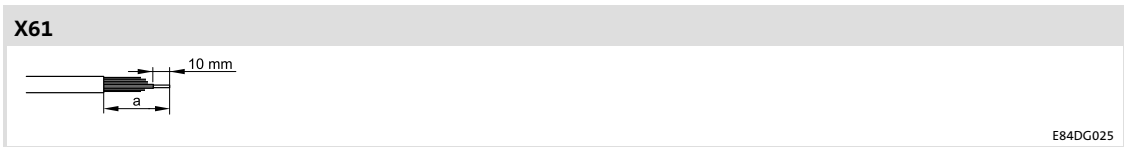

X61	a [mm]		[mm <sup>2</sup> ] [AWG]
Safety	55		0.5 ... 1.5 20 ... 16
			0.5 ... 1.0 20 ... 18
			0.5 20



**Note!**

The wiring connected for test purposes to the connections of the safety system must be removed (e.g. bridges SIA/SIB at 24O).



Declarations of conformity and certificates can be found on the internet at:<http://www.Lenze.com> and on the product CD.

## 9 Accessories (overview)

### 9.1 Wall mounting

#### 9.1.1 Wall adapter for 4 ... 7.5 kW

E84DZMAWE2

The wall adapter provides a good remedy, for instance if there is only little space available. The following things are to be taken into consideration:

- ▶ A suitable motor cable. Increases the installation effort. (📖 187)
- ▶ EMC-compliant installation (establishing the CE-typical drive system. (📖 80))

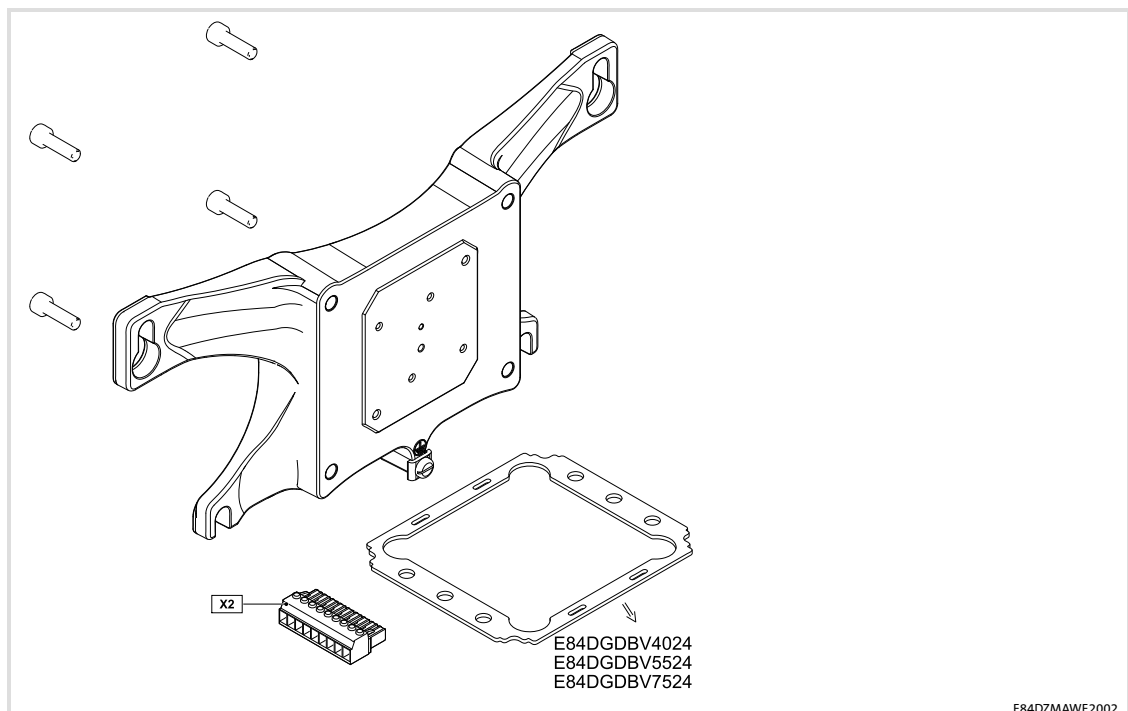

## 9 Accessories (overview)

Wall mounting  
Frame Unit without switch

### 9.1.2 Frame Unit without switch

The Frame Unit without switch is a simple wiring box for wall mounting and a power class up to 3.0 kW. The Frame Unit without switch can be configured as follows:

- ▶ Connections are pluggable for mains or looping-through connection (daisy chain), motor and brake resistor if required
- ▶ Versions for cable glands



Type	Connection system	Connection		Brake resistor	Position		Type Drive unit	
		Mains	Motor		3	5		
E84DGS2EENNNP	Cable gland	-	-	Not integrated			E84DGDVB3714PS E84DGDVB5514PS E84DGDVB7514PS E84DGDVB1124PS E84DGDVB1154PS E84DGDVB2224PS E84DGDVB3024PS	
E84DGS2EENKNP		-	-	Integrated				
E84DGS2SCNNNP	Pluggable	1x Quickon	1x Q8/0	Not integrated				
E84DGS2SCNKNP		1x Quickon	1x Q8/0	Integrated				
E84DGS2ICNNNP		1x M15	1x Q8/0	Not integrated				
E84DGS2ICNKNP		1x M15	1x Q8/0	Integrated				
E84DGS2KCNNNP		2x Q4/2	2x Q4/2	1x Q8/0	Not integrated			
E84DGS2KCNKNP					Integrated			
E84DGS2KCNMNP					Can be connected externally via 1x Q5/0			

### 9.1.3 Frame Unit with switch

The Frame Unit with switch is a wiring and switch box for wall mounting and a power class up to 3.0 kW. The Frame Unit with switch can be configured as follows:

- ▶ With service switch with protective function 1
- ▶ With service switch
- ▶ With service switch and control elements
- ▶ Connections are pluggable for mains or looping-through connection (daisy chain), motor and brake resistor if required
- ▶ Versions for cable glands

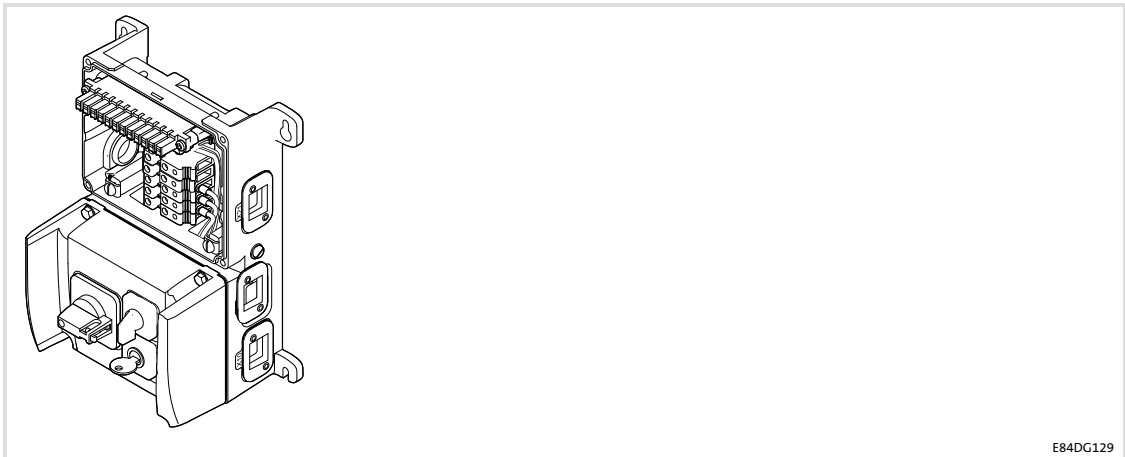

Type		Connection system	Connection		Brake resistor	Position		Type Drive unit
			Mains	Motor		3	5	
E84DGS3LEBNND	Service switch	Cable gland	-	-	Not integrated			E84DGDVB3714PS E84DGDVB5514PS E84DGDVB7514PS E84DGDVB1124PS E84DGDVB1154PS E84DGDVB2224PS E84DGDVB3024PS
E84DGS3LEKNND	Service switch with protective function							
E84DGS3LEENND	Service switch with control elements							
E84DGS3LEBCND	Service switch	Cable gland	-	-	Integrated			
E84DGS3LEKCND	Service switch with protective function							
E84DGS3LEECND	Service switch with control elements							
E84DGS3KCBNND	Service switch	Pluggable	2x Q4/2	1x Q8/0	Not integrated			
E84DGS3KCKNND	Service switch with protective function							
E84DGS3KCEENND	Service switch with control elements							
E84DGS3KCBCND	Service switch	Pluggable	2x Q4/2	1x Q8/0	Integrated			
E84DGS3KCKCND	Service switch with protective function							
E84DGS3KCECND	Service switch with control elements							
E84DGS3KCBLND	Service switch	Pluggable	2x Q4/2	1x Q8/0	Can be connected externally via 1x Q5/0			
E84DGS3KCKLND	Service switch with protective function							
E84DGS3KCELND	Service switch with control elements							

## 9.2 Plug connectors

### 9.2.1 M12 plug-in connector

The M12 plug-in connector can be easily mounted additionally in the Communication Unit by breaking out the cutouts. The wiring in the Communication Unit is implemented on plug-in terminals, thus making it possible to design additional pluggable I/O's.

Mode	Features	M12 plug
<b>M12 plug</b> EZA EVE013/M	<ul style="list-style-type: none"> <li>• A-coded, 5-pole, female</li> <li>• Packaging unit: 5 items</li> </ul>	

### 9.2.2 Plug-in modules







By default, cables for the connection of the mains and the motor are led into the WU by means of cable glands. Alternatively, plug-in modules with prewired Q-plugs can be supplied for mounting on the right or the left.

For plug-in modules with a Q-plug, an M25 bore for an additional cable gland is available.

Plug-in modules with two Q-plugs are designed for a looping-through connection (daisy-chain). Like this it is possible to use a supply bus for the machine design.

If wall mounting is implemented, the plug-in modules with a Q8-plug enable the motor connection as a plug&drive drive, in particular with Lenze system cables.

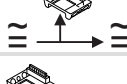
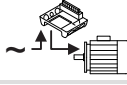

In the table the retrofittable plug-in modules are listed.

		X...	U <sub>max</sub> [V]	I <sub>max</sub> [A]		IP
E84DZEVLANP <sup>1)</sup>	L	X10: Q5	400 ~	16 ~		IP65
E84DZEVBANP <sup>1)</sup>	R					
E84DZEVLAFP <sup>1)</sup>	L	X10: Q5 X11: Q5	480 ~	32 ~	 ≤ E84DGDVB3024...	
E84DZEVBRAFP <sup>1)</sup>	R					
E84DZEVLPNP	L	X10: Q4/2	24 =	10 =		
E84DZEVBPNP	R					
E84DZEVLPRP	L	X10: Q4/2 X11: Q4/2	480 ~	16		
E84DZEVBPRP	R					
E84DZEVLBCNP <sup>1)</sup>	L	X21: Q8	480 ~	20 UL: 15 ~		
E84DZEVBRCNP <sup>1)</sup>	R					
E84DZEVLBCSP <sup>2)</sup>	L	X10: Quickon X21: Q8	480 ~	16		
E84DZEVBRCFP <sup>1)</sup>	R	X20: Q5 X21: Q8				



1) ✓ P<sub>aN</sub> ≤ 7.5 kW

2) ✓ P<sub>aN</sub> ≤ 3.0 kW

## 9.2.3 QUICKON connector

Version	Features	QUICKON
<b>QUICKON wall bushing</b> EWS0102	<ul style="list-style-type: none"> <li>• Applications with simple mains connection directly at the Wiring Unit or Frame Unit</li> <li>• Suitable for a rated power up to <math>\leq 3</math> kW</li> <li>• For all sizes, 20A / 690V (UL: 15 A / 690V)</li> <li>• UL in preparation</li> </ul>	
<b>QUICKON nut</b>	<ul style="list-style-type: none"> <li>• Connectability max. 10</li> <li>• Packaging unit: 5 items</li> </ul>	
EWS0103/M	<ul style="list-style-type: none"> <li>• Cable diameter 6 ... 10 mm</li> </ul>	
EWS0104/M	<ul style="list-style-type: none"> <li>• Cable diameter 9 ... 14 mm</li> </ul>	
<b>QUICKON connector with Quickon nut</b>	<ul style="list-style-type: none"> <li>• Plug cycles: more than 50</li> <li>• Packaging unit: 5 items</li> </ul>	
EWS0105/M	<ul style="list-style-type: none"> <li>• Cable diameter 6 ... 10 mm</li> </ul>	
EWS0106/M	<ul style="list-style-type: none"> <li>• Cable diameter 9 ... 14 mm</li> </ul>	

## 9.2.4 M15 plug

Version	Features	M15 plug
<b>M15 wall bushing</b> EWS0107	<ul style="list-style-type: none"> <li>• Applications with simple mains connection directly at the Wiring Unit or Frame Unit</li> <li>• 4 power contacts and PE: 16 A / 600 V</li> <li>• 2 control contacts: 10 A / 24 V</li> <li>• Suitable for a rated power up to <math>\leq 3</math> kW</li> <li>• UL in preparation</li> </ul>	
<b>M15 plug</b> EWS0109/M	<ul style="list-style-type: none"> <li>• Connection cross-section 6 x 2.5 mm<sup>2</sup></li> <li>• Crimp sockets</li> <li>• Plastics without shielding</li> <li>• Packaging unit: 5 items</li> </ul>	

### 9.3 Memory module

In the memory module, the parameters of the inverter are stored. The pluggable memory module provides for a quick parameter set transfer to an inverter of the same design. Possible reasons for a parameter set transfer:

- ▶ Duplication of similar applications in a series of identical drives.
- ▶ Restorage of an application after device replacement.

The required steps for a parameter set transfer are described in the software manual.

In order to remove the memory module, use a suitable screwdriver to lever the module out at the upper and lower groove. In order to plug in the module, insert it into the slot and push it with light pressure until end position is reached.

Mode	Features	Memory module
<b>Memory module</b> E84AYM20S/M	<ul style="list-style-type: none"> <li>● For 8400 BaseLine, 8400 motec</li> <li>● Packaging unit: 12 items</li> </ul>	

## 9.4 Diagnosis terminal

The X400 diagnosis terminal is a simple means for parameter setting and diagnostics on site. Clearly structured menus and a plain text menu provide for quick data access. The diagnosis terminal is connected to the X70 diagnostic interface. The diagnosis terminal is based on the X400 keypad, extended by a holder and a connecting cable.

Mode	Features	Diagnosis terminal
<b>Diagnosis terminal</b> EZAEBK2001	<ul style="list-style-type: none"> <li>● 2.5 m connecting cable, exchangeable</li> <li>● Menu-driven diagnostics and parameter setting</li> <li>● Backlighted graphic display for representing information</li> <li>● 4 navigation keys, 2 context-sensitive keys</li> <li>● Adjustable RUN/STOP function</li> <li>● Supports hot plugging</li> <li>● Enclosure IP20</li> </ul>	

## 9.5 Switch/potentiometer unit

By means of the switch/potentiometer unit and the 8400 motec inverter integrated in the inverter, an analog setpoint can be predefined using the integrated potentiometer. Via the rotary switch, the drive can for example be started or stopped, or the direction of rotation can be changed.

Mode	Features	Switch/potentiometer unit
<b>Switch/potentiometer unit</b> E82ZBU	<ul style="list-style-type: none"> <li>● 2.5 m connecting cable</li> <li>● IP65 enclosure</li> </ul>	

9.6

External brake resistors - mounting variant

E84DZEWxxxx001

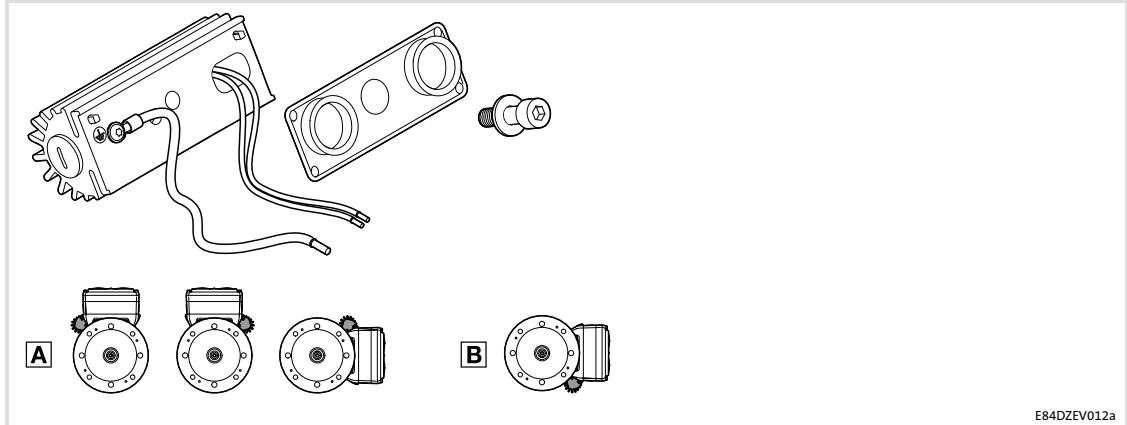

E84DZEW012a

	R <sub>B</sub> (C00129)	P <sub>D</sub> (C00130)		Q <sub>B</sub> (C00131)	C00574	IP	E84DGDVB...
		A	B				
	[Ω]	[W]	[W]	[kW]	=		
E84DZEW220R001	220	40	30	0.6	1 Fault	IP65	3714 5514 7514 1124 1524
E84DZEW100R001	100	40	30	0.6	1 Fault	IP65	2224 3024
E84DZEW47R0001	47	40	30	0.6	1 Fault	IP65	4024 5524 7524

## 9.7 External brake resistors

Braking greater moments of inertia or longer operation in generator mode requires the use of an external brake resistor.

The brake resistors recommended in the table below are dimensioned to approx. 1.5 times the regenerative power at a cycle time of 15/135 s (brake/pause ratio). As a general rule, these brake resistors meet the common requirements with regard to standard applications.

The brake resistors are provided with a thermostat (potential-free NC contact).

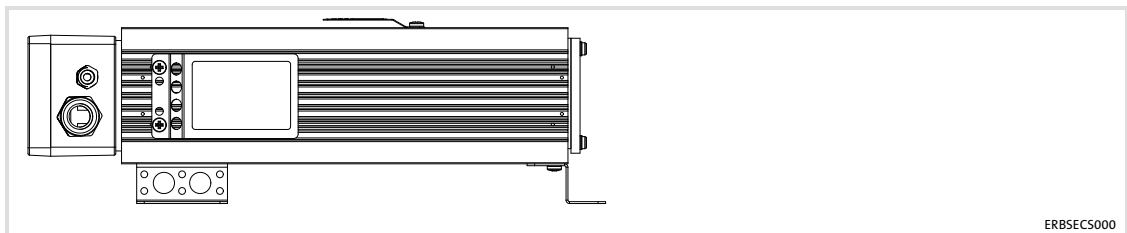

Typical motor power <sup>1)</sup>	Mains voltage	Brake resistor	Rated resistance	Rated power	Heat capacity	Dimensions	Mass
P [kW]	U <sub>AC</sub> [V]		R <sub>rated</sub> [Ω]	P <sub>rated</sub> [W]	C <sub>th</sub> [kWs]	h × b × t [mm]	m [kg]
0.37	3 AC 320 ... 528	ERBS180R350W	180.0	350.0	53.0	382 × 124 × 122	2.0
0.55							
0.75							
1.10							
1.50							
2.20		ERBS100R625W	100.0	625.0	94.0	566 × 124 × 122	3.0
3.00							
4.00							
5.50		ERBS047R400W ERBS047R800W	47.0	400.0 800.0	60.0 120.0	400 × 110 × 105 710 × 110 × 105	2.3 3.9
7.50							

<sup>1)</sup> Typical motor power of a 4-pole asynchronous motor

**10**      **Appendix**

**10.1**      **Total index**

**0 ... 9**

**8400 motec set, motec set, 27**

**A**

**Accessories, 187**

- Brake resistor, 172

**Ambient conditions**

- climatic, 34

- mechanical, 34

**B**

**Brake resistor, 58, 61, 64**

- Selection, 172

- Wiring, 173

**Braking, 171**

**Braking operation, 171**

- DC injection brake DCB, 171

- with brake resistor, 172

- without additional measures, 171

**C**

**Cable**

- For control connections, 82

- for the motor connection, 81

**Cables**

- cross-sections, 40, 42, 44, 46

- fuses, 40, 42, 44, 46

**CANopen, 68, 122**

- STO, 124

**Commissioning, 146**

- before you start, 146

**Communication Unit, 26**

**Control cable, 82**

**Control terminals, 65, 114**

**D**

**Definition of notes used, 12**

**Definitions, Terms, 11**

**Device features, 21**

**Device protection, 19, 76**

**Diagnosis terminal, 194**

**Disconnecting paths, 181**

**Disposal, 15**

**Drive Unit, 26**

- settings, 89

**E**

**Electrical installation, 185**

**EMC, what to do in case of interferences, 82**

**EN 61000-3-2, 35**

**Enclosure, 32**

**F**

**Frame Unit, 25**

**Fuses, 40, 42, 44, 46**

- operation with rated power, 400 V (UL), 40, 44

**G**

**General data, 66**

**H**

**Harmonic currents, limitation according to EN 61000-3-2, 35**

**Hazard analysis, 179**

**I**

**Identification, 23**

**Installation, 75**

- electrical, 185

**Interferences, eliminating EMC interferences, 82**

**Introduction, 181**

**IT system, 91**

- measures, 91

**M**

**Mains current, 39, 41, 43, 45**

**Memory module, 148, 193**

**Menu structure, 164**

**Motor cable, 81**

- length, 34

**Motor power, typical, 39, 41, 43, 45**

Motor protection, 19

Mounting place, 34

Mounting position, 34

## N

Nameplate, 23

Noise emission, 35

Noise immunity, 35

Notes, definition, 12

## O

Operating conditions, ambient conditions

- climatic, 34

- mechanical, 34

Operation, Overcurrent, 53

Output power, 39, 41, 43, 45

Output voltage, maximum, 37

Output voltage , 37

Overspeeds, 19

Overview

- Accessories, 187

- control terminals, 30

## P

Pollution, 34

Power system, 34

Power terminals, 56, 95

Product description, 20

Protection of persons, 19

Protective insulation of control circuits, 33

Protective measures, 33

## R

Rated data

- Operation with increased power, 400 V mains, 41

- operation with increased power , 480 V system, 45

Residual hazards, 19, 179

Risk analysis, 179

## S

Safety, safety engineering, 177

Safety engineering, 177

- application as directed, 178

- Certification, 186

Safety functions, safety instructions, during operation, 179

Safety instructions, 13

- definition, 12

- during operation, 179

- layout, 12

Safety status, 182

Sensors, basics, 180

Site altitude, 34

Supply conditions, 34

- mains, 34

- motor, 34

Switching frequency reduction, 55

System overview, 65

## T

Technical data, 32, 183

- General data, 66

- Operation with increased power, 400 V mains, 41

- operation with increased power , 480 V system, 45

Terms, definitions, 11

Total index, 198

Type code, finding, 23

## U

Use in IT systems, 91

User menu, 165

## V

Validity, documentation, 8

## W

Wall mounting

- with switch, 29, 50, 74, 94, 106

- without switch, 28, 47, 73, 94, 97

Wiring, Brake resistor, 173

Wiring Unit, 24



© 02/2019

Lenze Drives GmbH  
Postfach 10 13 52, 31763 Hameln  
Breslauer Straße 3, 32699 Extertal  
GERMANY  
HR Lemgo B 6478



+49 5154 82-0



+49 5154 82-2800



[sales.de@lenze.com](mailto:sales.de@lenze.com)



[www.lenze.com](http://www.lenze.com)

Service

Lenze Service GmbH  
Breslauer Straße 3, D-32699 Extertal

Germany



008000 2446877 (24 h helpline)



+49 5154 82-1112



[service.de@lenze.com](mailto:service.de@lenze.com)

EDS84DG752 ■ 13563424 ■ EN ■ 8.1 ■ TD15

10 9 8 7 6 5 4 3 2 1